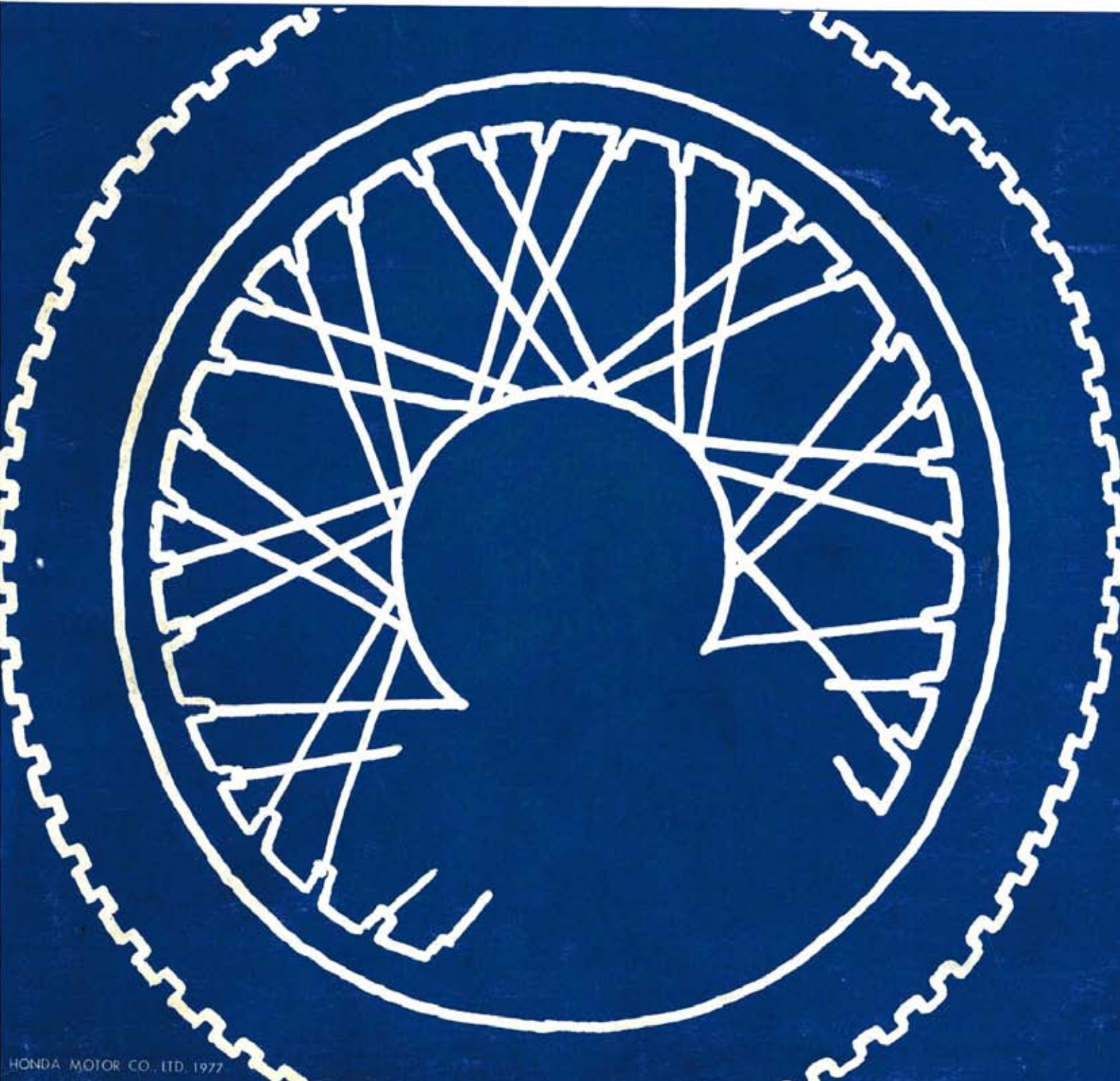


SHOP MANUAL

HONDA CB 750

Courtesy of  Honda4Fun
www.honda4fun.com



FOREWORD

This shop manual describes the maintenance, inspection and adjustment procedures for the HONDA CB750 and CB750F.

The manual is divided into various functional groups to simplify the use. The pages for the respective groups are indexed on this pages for convenience.

Each of the groups are further divided into section 1. Description, 2. Specifications, 3. Diagnosis, 4. Disassembly, 5. Inspection and 6. Reassembly. Photographs and illustrations make the operations easier to understand.

Following are the initial serial numbers of each model at the time of change.

| | |
|---------------|--------------------|
| CB750 | Frame No. 1000001~ |
| CB750K1 | Frame No. 1055004~ |
| CB750K2 | Frame No. 2000001~ |
| CB750K3 | Frame No. 2200001~ |
| CB750K4 | Frame No. 2341915~ |
| CB750K5 | Frame No. 2525947~ |
| CB750F | Frame No. 1000002~ |
| CB750F1 | Frame No. 2000003~ |
| CB750K6 | Frame No. 2540001~ |
| CB750K7 ('77) | Frame No. 2700002~ |
| CB750F ('77) | Frame No. 2100001~ |
| CB750K ('78) | Frame No. 2800001~ |
| CB750F ('78) | Frame No. 3100002~ |

HONDA MOTOR CO., LTD

Service Publications Office

GROUP INDEX

1. GENERAL INFORMATION. . . 1~15
2. ENGINE REMOVAL AND INSTALLATION. 17~19
3. ENGINE MECHANICAL. 21~55
4. CLUTCH. 57~61
5. TRANSMISSION. 63~70
6. FUEL SYSTEM. 71~82
7. IGNITION SYSTEM 83~92
8. CHARGING SYSTEM. 93~102
9. STARTING SYSTEM 103~108
10. BATTERY 109~113
11. STEERING AND FRONT SUSPENSION. 115~122
12. REAR SUSPENSION. 123~128
13. WHEELS, TIRES AND FINAL DRIVE 129~139
14. BRAKES 141~149
15. BODY, OIL TANK, AIR CLEANER AND EXHAUST SYSTEM. 151~156
16. BODY ELECTRICAL AND INSTRUMENTS 157~170
17. WIRING DIAGRAM. 171~172
18. ENGINE TUNE-UP. 173~174
19. PERIODICAL MAINTENANCE. 175~188
20. SUPPLEMENT TO CB750 K1~K4. 189~220
21. SUPPLEMENT TO CB750 K5. 221~224
22. SUPPLEMENT TO CB750 F. 225~248
23. SUPPLEMENT TO CB750 K 6 ('76). 249~252
24. SUPPLEMENT TO CB750 K 7 ('77). 253~264
25. SUPPLEMENT TO CB750 F ('77). 265~273
26. SUPPLEMENT TO CB750 K ('78) 275~279
27. SUPPLEMENT TO CB750 F ('78) 281~283

ALL INFORMATION, ILLUSTRATIONS, DIRECTIONS AND SPECIFICATIONS INCLUDED IN THIS PUBLICATION ARE BASED ON THE LATEST PRODUCT INFORMATION AVAILABLE AT THE TIME OF APPROVAL FOR PRINTING. HONDA MOTOR CO., LTD. RESERVES THE RIGHT TO MAKE CHANGES AT ANY TIME WITHOUT NOTICE AND WITHOUT INCURRING ANY OBLIGATION WHATEVER.

NO PART OF THIS PUBLICATION MAY BE REPRODUCED WITHOUT WRITTEN PERMISSION.

GENERAL INFORMATION

GROUP 1

CONTENTS

| | |
|------------------------------|----|
| 1-1 SERIAL NUMBER | 1 |
| 1-2 KEY SYSTEM | 2 |
| 1-3 TECHNICAL DATA..... | 3 |
| a. Dimensional drawing | 3 |
| b. Specifications..... | 4 |
| c. Driving performance..... | 10 |
| 1-4 THREAD SIZE | 11 |
| 1-5 SERVICE TOOLS..... | 12 |

Courtesy of  Honda4Fun
www.hondafour.com www.honda4fun.com

1-1 SERIAL NUMBER

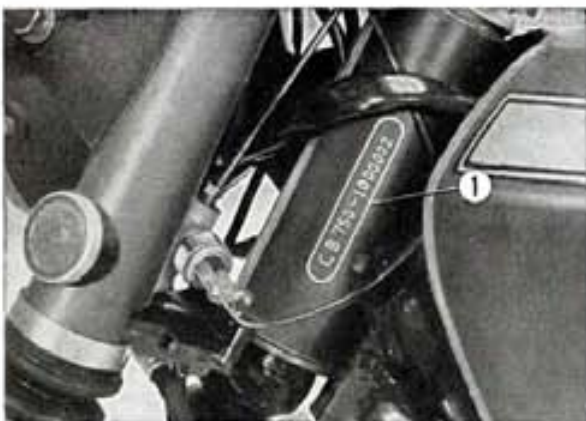


Fig. 1-1 ① Frame serial number

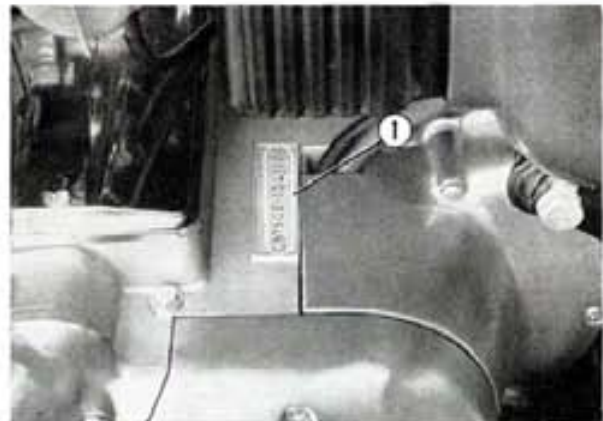


Fig. 1-2 ① Engine serial number

The frame serial number is stamped on the left side of the steering head pipe and engine serial number is located on the top of the crankcase left side. Whenever ordering replacement parts or making inquiries concerning the particular motorcycle, always included the frame or the engine number whichever is applicable. (Fig. 1-1, 2)

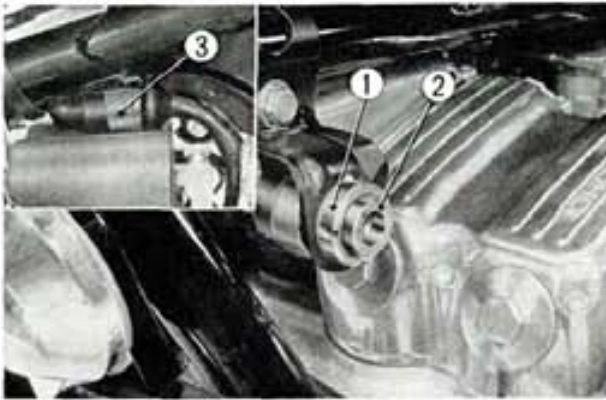


Fig. 1-3 ① Lock nut
② Main Ignition switch
③ Coupler

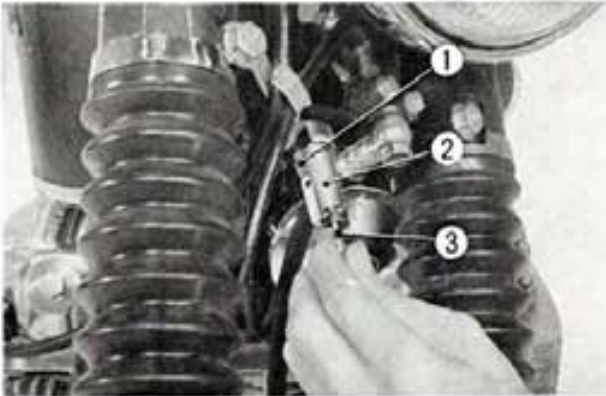


Fig. 1-4 ① Lock spring
② Handle lock
③ Key

1-2 KEY SYSTEM

The key is used to operate both the main ignition switch and the handle lock.

Four keys are provided for each motorcycle, two are to be given to the user and the remaining two are to be kept in custody of the dealer from whom the motorcycle is purchased so that they can be supplied as a spare to the user when they are lost. A rubber cap is provided to cover the head of the key which is in use. The same code number is stamped on the key and ignition switch. When the key is lost refer to the switch code. In case all spare keys are waste, the main ignition switch and the handle lock (key, main ignition switch and handle lock are sold in sets) must be replaced in set.

a. Replacement of main ignition switch

1. Loosen the main ignition switch lock nut and remove the switch from the switch bracket. (Fig. 1-3)
2. Disconnect the main switch coupler.
3. Install the new switch on the switch bracket and positively connect the coupler.

b. Replacement of handle lock

1. Remove the handle lock case mounting screw with a cross point screw driver and remove the lock case
2. Insert the key into the handle lock and turn counter clockwise approximately 60° and then the handle lock can be removed from the steering stem. (Fig. 1-4)
3. Install the new handle lock in the reverse order of removal procedure described above.

Do not forget to assemble the handle lock spring.

1-3 TECHNICAL DATA

a. Dimensional drawing

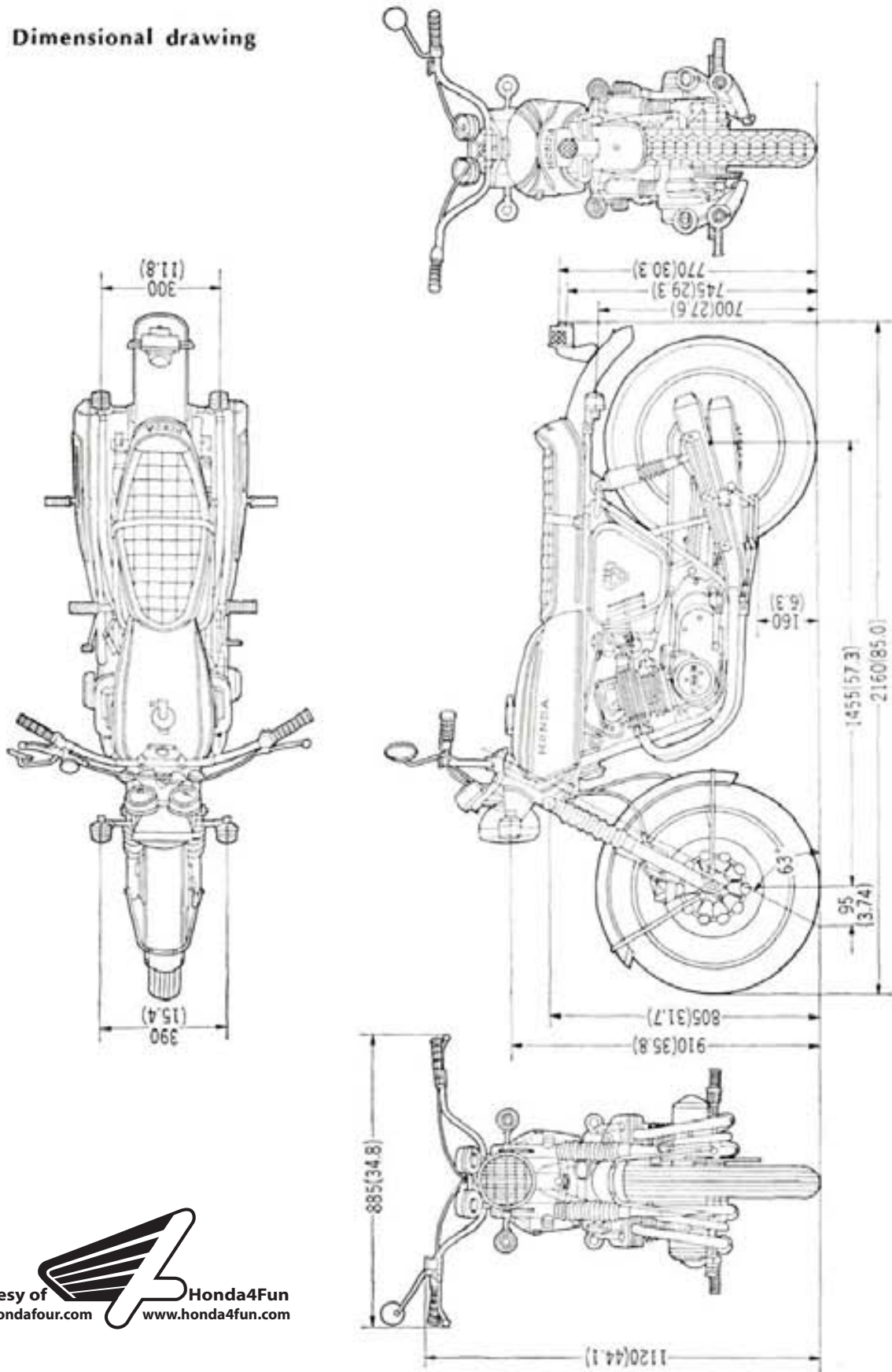


Fig. 1-5



b. Specifications CB 750

| | Item | English | Metric |
|-------------------------|-------------------------|---------------------------------|---|
| DIMENSION | Overall Length | 85.0 in. | 2,160 mm |
| | Overall Width | 34.8 in. | 885 mm |
| | Overall Height | 45.5 in. | 1,155 mm |
| | Wheel Base | 57.3 in. | 1,455 mm |
| | Seat Height | 31.5 in. | 800 mm |
| | Foot Peg Height | 12.2 in. | 310 mm |
| | Ground Clearance | 5.5 in. | 160 mm |
| | Curb Weight | 517.3 lb. | 235 kg |
| | Weight Distribution L/R | 271.1/209.5 lb. | 123/205 kg |
| FRAME | Type | Double cradle tubular steel | |
| | F. Suspension, Travel | Telescopic fork, travel 5.6 in. | 143 mm |
| | R. Suspension, Travel | Swing arm, travel 3.3 in. | 85 mm |
| | F. Tire Size, Type | 3.25-19 (4 PR) Rib tire, | tire air pressure 2.0 kg/cm ² , 28 psi |
| | R. Tire Size, Type | 4.00-18 (4 PR) Block tire, | tire air pressure 2.0 kg/cm ² , 28 psi |
| | F. Brake, Lining Area | Disc brake, | lining area 2.9 in ² ×2, 19 cm ² ×2 |
| | R. Brake, Lining Area | Internal exanding shoe, | lining area 8.2 in ² ×2, 53 cm ² ×2 |
| | Fuel Capacity | 4.7 U.S. gal. 3.9 Imp. gal. | 18 lit. |
| | Fuel Reserve Capacity | 1.3 U.S. gal. 1.1 Imp. gal. | 5 lit. |
| | Caster Angle | 63° | |
| | Trail Length | 3.74 in. | 95 mm |
| | Front Fork Oil Capacity | 7.0-7.3 ozs | 220-230 cc |
| | ENGINE | Type | Air-cooled, 4-stroke, O.H.C. engine |
| Cylinder Arrangement | | 4-cylinder in line | |
| Bore and Stroke | | 2.401×2.408 in. | 61×63 mm |
| Displacement | | 44.93 cu in. | 736 cc |
| Compression Ratio | | 9.0 | |
| Carburetor, Venturi Dia | | Four, piston valve, 28 mm dia. | |
| Valve Train | | Chain drive overhead camshaft | |
| Maximum Horsepower | | 67 BHP/8,000 rpm | |
| Maximum Torque | | 44.12 lb-ft/7,000 rpm | 6.1 kg-m/7,000 rpm |
| Oil Capacity | | 7.39 U.S. pt., 6.16 Imp. pt. | 3.5 lit. |
| Oil Tank Capacity | | 4.22 U.S. pt., 3.55 Imp. pt. | 2 lit. |
| Lubrication System | | Forced pressure and dry sump | |
| Air Filtration | | Paper element | |



| | Item | English | Metric |
|--------------------|---|--|-----------------------|
| | Valve Tappet Clearance | IN: 0.002, EX: 0.003 in. | IN: 0.05, EX: 0.08 mm |
| | Engine weight (include oil) | 176.3 lb. | 80 kg |
| | Air Screw Opening | 1 ± 1/8 | |
| | Idle Speed | 900 rpm | |
| DRIVE TRAIN | Clutch | Wet, multi-plate | |
| | Transmission | 5-speed, constant mesh | |
| | Primary Reduction, Secondary Reduction | Primary: 1.708, Secondary: 1.167 | |
| | Gear Ratio I | 2.500 | |
| | " II | 1.708 | |
| | " III | 1.333 | |
| | " IV | 1.097 | |
| | " V | 0.939 | |
| | Final Reducion | 2.667, drive sprocket 18 T, driven sprocket 48 T | |
| | Gear Shift Pattern | Left foot return type | |
| Ignition | Battery and ignition coil | | |
| Starting System | Electrical motor and kick pedal | | |
| Alternator | Three phase A.C. 12 V-0.12 kW/5,000 rpm | | |
| Battery Capacity | 12 V-14 AH | | |
| Spark plug | NGK D-8 ES | | |



CB 750 K 1

| Item | | English | Metric | |
|------------------------------------|-------------------------|---|---------------------------------------|--|
| Dimension | Overall length | 85.0 in. | 2,160 mm | |
| | Overall width | 34.8 in. | 885 mm | |
| | Overall height | 44.5 in. | 1,155 mm | |
| | Wheel base | 57.3 in. | 1,455 mm | |
| | Seat height | 31.5 in. | 800 mm | |
| | Foot peg height | 12.2 in. | 310 mm | |
| | Ground clearance | 5.5 in. | 140 mm | |
| | Dry weight | 479 lb. | 218 kg | |
| Frame | Type | Double cradle | | |
| | F. suspension, travel | Telescopic fork, travel 5.6 in. (143 mm) | | |
| | R. suspension, travel | Swing arm, travel 3.3 in. (85 mm) | | |
| | F. tire size, pressure | 3.25-19 (4 PR) Rib pattern, tire air pressure | 2.0 kg/cm ² (28 psi) | |
| | R. tire size, pressure | 4.00-18 (4 PR) Block pattern, tire air pressure | 2.0 kg/cm ² (28 psi) | |
| | F. brake, lining area | Disk brake, lining swept area | 59.3 sq. in. (382.9 cm ²) | |
| | R. brake, lining area | Internal expanding shoe, lining swept | 33.2 sq. in. (220.5 cm ²) | |
| | Fuel capacity | 4.5 U.S. gal. 3.7 Imp. gal. | 17 lit | |
| | Fuel reserve capacity | 1.3 U.S. gal. 1.1 Imp. gal. | 5 lit | |
| | Caster angle | 63° | | |
| | Trail length | 3.7 in | 95 mm | |
| | Front fork oil capacity | 7.5-7.8 ozs | 220-230 cc (to fill if dry) | |
| | Front fork oil capacity | 6.9-7.1 ozs | 200-210 cc (to fill after draining) | |
| | Engine | Type | Air cooled, 4 stroke O.H.C. engine | |
| Cylinder arrangement | | 4 cylinder in line | | |
| Bore and stroke | | 2.402×2.480 in. | 61.0×63.0 mm | |
| Displacement | | 44.9 cu-in. | 736 cc | |
| Compression ratio | | 9.0 : 1 | | |
| Valve train | | Chain driven over head camshaft | | |
| Oil capacity | | 3.7 U.S. qt. 3.1 Imp. qt. | 3.5 lit | |
| Lubrication system | | Forced pressure and dry sump | | |
| Cylinder head compression pressure | | 12 kg/cm ² (170.7 psi) | | |
| Intake valve | | Open | At 5° (before top dead center) | |
| | | Close | At 30° (after bottom dead center) | |
| Exhaust valve | | Open | At 35° (before bottom dead center) | |
| | | Close | At 5° (after top dead center) | |
| Valve tappet clearance | | IN: 0.002, EX: 0.003 in. | IN: 0.05, EX: 0.08 mm | |
| Idle Speed | | 950 rpm | | |

Courtesy of  Honda4Fun
www.hondafour.com www.honda4fun.com

| | | English | Metric |
|-------------|-----------------------------|---|--------|
| Carburetor | Type | Piston valve | |
| | Setting mark | 7A | |
| | Main jet | #120 | |
| | Slow jet | # 40 | |
| | Air screw opening | 1±3/8 turns | |
| | Float height | 0.866 in. 26 mm | |
| Drive train | Clutch | Wet multi plate type | |
| | Transmission | 5-speed constant mesh | |
| | Primary reduction | 1.708 | |
| | Gear ratio I | 2.500 | |
| | Gear ratio II | 1.708 | |
| | Gear ratio III | 1.333 | |
| | Gear ratio VI | 1.097 | |
| | Gear ratio V | 1.939 | |
| | Final reduction | 2.667, drive sprocket 18 T, driven sprocket 48 T | |
| | Gear shift pattern | Left foot operated return system | |
| Electrical | Ignition | Battery and ignition coil | |
| | Starting system | Starting motor or kick starter | |
| | Alternator | Three phase A.C. generator 12 V/0.21 kW/5,000 rpm | |
| | Battery capacity | 12 V-14 AH | |
| | Spark plug | NGK DBES-L, NDX 24ES | |
| | Headlight | Low/high 12 V-40 W/50 W | |
| | Tail/stoplight | Tail/stop 12 V-7/23 W (SEA TRADE No. 1157) | |
| | Turn signal-light | Front/rear 12 V-23/23 W | |
| | Speedometer light | 12 V-3 W | |
| | Tachometer light | 12 V-3 W | |
| | Neutral indicator light | 12 V-3 W | |
| | Turn signal indicator light | 12 V-3 W | |
| | High bean indicator light | 12 V-3 W | |



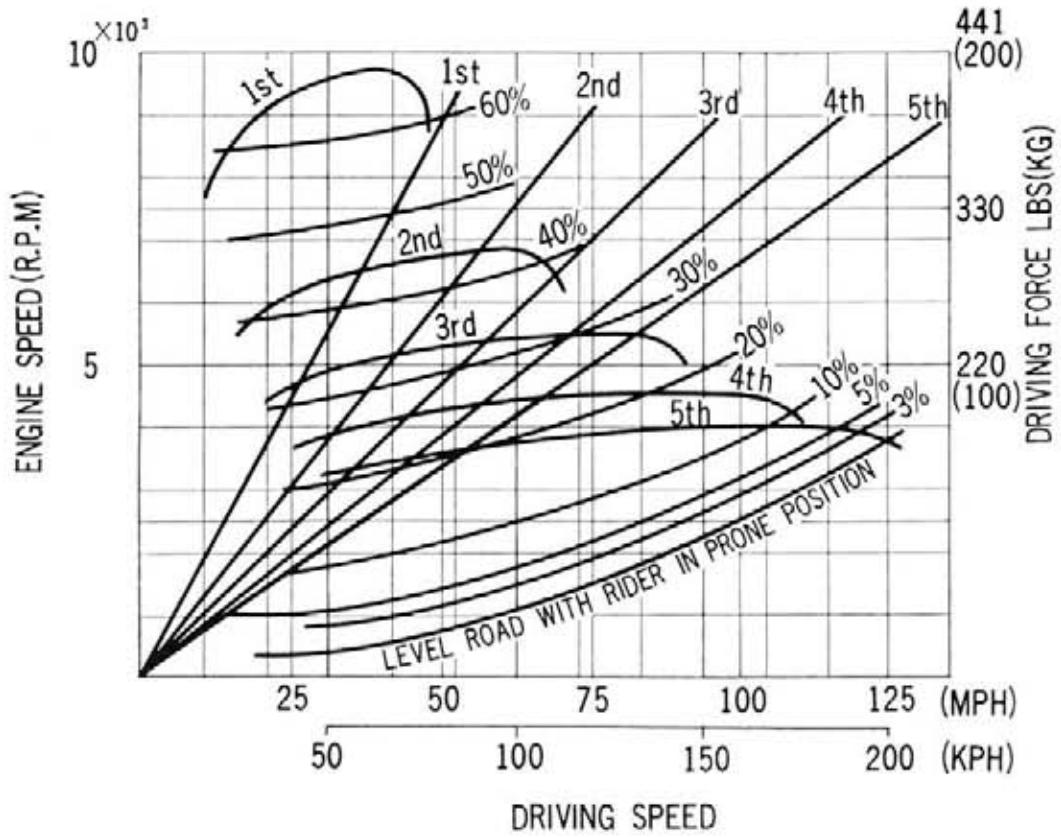
CB 750 K2, K3, K4

| | Item | English | Metric | |
|------------|------------------------------------|---|-------------------------------------|--|
| Dimension | Overall length | 85.6 in. | 2,175 mm | |
| | Overall width | 34.3 in. | 870 mm | |
| | Overall height | 46.1 in. | 1,170 mm | |
| | Wheel base | 57.3 in. | 1,455 mm | |
| | Seat height | 31.9 in. | 810 mm | |
| | Foot peg height | 12.2 in. | 310 mm | |
| | Ground clearance | 5.5 in. | 140 mm | |
| | Dry weight | 479 lb. | 218 kg | |
| Frame | Type | Double cradle | | |
| | F. suspension, travel | Telescopic fork, travel 5.6 in. (143 mm) | | |
| | R. suspension, travel | Swing arm, travel 3.3 in. (85 mm) | | |
| | F. tire size, pressure | 3.25-19 (4 PR) Rib pattern, tire air pressure 2.0 kg/cm ² (28 psi) | | |
| | R. tire size, pressure | 4.00-18 (4 PR) Block pattern, tire air pressure 2.0 kg/cm ² (28 psi) | | |
| | F. brake, lining area | Disk brake, lining swept area 59.3 sq. in. (382.9 cm ²) | | |
| | R. brake, lining area | Internal expanding shoe, lining swept 34.2 sq. in. (220.5 cm ²) | | |
| | Fuel capacity | 4.5 U.S. gal. 3.7 Imp. gal. | 17 lit | |
| | Fuel reserve capacity | 1.3 U.S. gal. 1.1 Imp. gal. | 5 lit | |
| | Caster angle | 63° | | |
| | Trail length | 3.7 in. | 95 mm | |
| | Front fork oil capacity | 7.5-7.8 ozs | 220-230 cc (to fill if dry) | |
| | Front fork oil capacity | 5.3-5.4 ozs | 155-160 cc (to fill after draining) | |
| Engine | Type | Air cooled, 4 stroke O.H.C. engine | | |
| | Cylinder arrangement | 4 cylinder in line | | |
| | Bore and stroke | 2.402×2.480 in. | 61.0×63.0 mm | |
| | Displacement | 44.9 cu-in. | 736 cc | |
| | Compression ratio | 9.0 : 1 | | |
| | Valve train | Chain driven over head camshaft | | |
| | Oil capacity | 3.7 U.S. qt. 3.1 Imp. qt. | 3.5 lit | |
| | Lubrication system | Forced pressure and dry sump | | |
| | Cylinder head compression pressure | 12 kg/cm ² (170.7 psi) | | |
| | Intake valve | Open | At 5° (before top dead center) | |
| | | Close | At 30° (after bottom dead center) | |
| | Exhaust valve | Open | At 35° (before bottom dead center) | |
| | | Close | At 5° (after top dead center) | |
| | Valve tappet clearance | IN: 0.002, EX: 0.003 in. | IN: 0.05, EX: 0.08 mm | |
| Idle speed | 950 rpm | | | |



| | Item | English | Metric | |
|-------------|-----------------------------|---|--|--|
| Carburetor | Type | Piston valve | | |
| | Setting mark | 7A | | |
| | Main jet | #120 (K3, #105) | | |
| | Slow jet | # 40 | | |
| | Air screw opening | 1±3/8 turns | | |
| | Float height | 0.866 in. 26 mm | | |
| Drive train | Clutch | Wet multi plate type | | |
| | Transmission | 5-speed constant mesh | | |
| | Primary reduction | 1.708 | | |
| | Gear ratio I | 2.500 | | |
| | Gear ratio II | 1.708 | | |
| | Gear ratio III | 1.333 | | |
| | Gear ratio VI | 1.097 | | |
| | Gear ratio V | 1.939 | | |
| | Final reduction | 2.667, drive sprocket 18 T, driven sprocket 48 T | | |
| | Gear shift pattern | Left foot operated return system | | |
| Electrical | Ignition | Battery and ignition coil | | |
| | Starting system | Starting motor or kick starter | | |
| | Alternator | Three phase A.C. generator 12 V/0.21 kW/5,000 rpm | | |
| | Battery capacity | 12 V-14 AH | | |
| | Spark plug | NGK D8E5-L, NDX 24E5 | | |
| | Headlight | Low/high | 12 V-40 W/50 W | |
| | Tail/stoptlight | Tail/stop | 12 V-3/32 CP (SAE TRADE No. 1157) | |
| | Turn signal-light | Front/rear | 12 V-32/32 CP (SAE TRADE No. R1034, L1073) | |
| | Speedometer light | 12 V-2 CP (SAE TRADE No. 57) | | |
| | Tachometer light | 12 V-2 CP (SAE TRADE No. 57) | | |
| | Neutral indicator light | 12 V-2 CP (SAE TRADE No. 57) | | |
| | Turn signal indicator light | 12 V-2 CP (SAE TRADE No. 57) | | |
| | High beam indicator light | 12 V-2 CP (SAE TRADE No. 57) | | |
| | Position Light | 12 V-4 CP (SAE TRADE No. —) | | |

c. Driving Performance Curve (One Rider)



Driving Performance Curve (Two Rider)

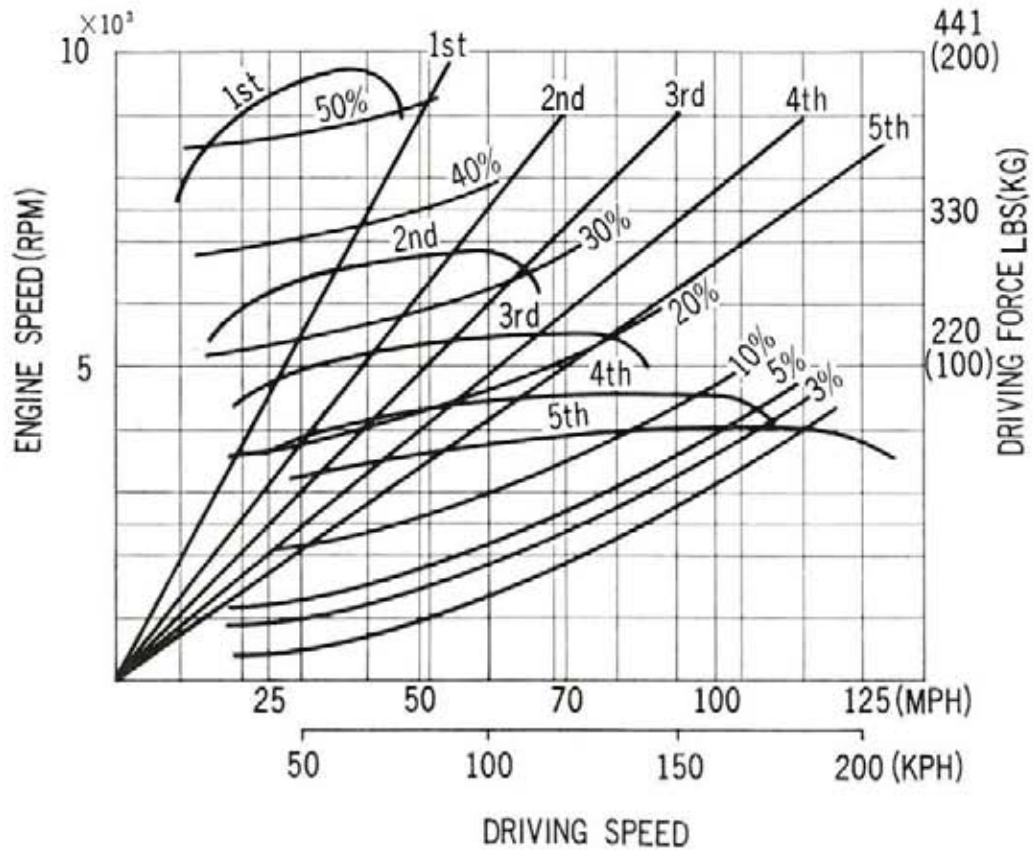


Fig. 1-6

1-4 THREAD SIZE

All threaded parts used on the HONDA CB750 conform to ISO Standard (International Standardization Organization).

The differences between the dimensions of the JIS (Japan Industrial Standard) bolts, which were previously used, and the ISO bolts are in the thread pitch, width across flat and the thickness of the head. Do not use any JIS thread to fit ISO thread, otherwise the thread will be damaged. The width across flat is also different from JIS standard except 6 mm bolt or nut, thus the wrenches are not common to the ones based on JIS standard except 10 mm. The table below lists these dimensions for the ISO standard bolts.

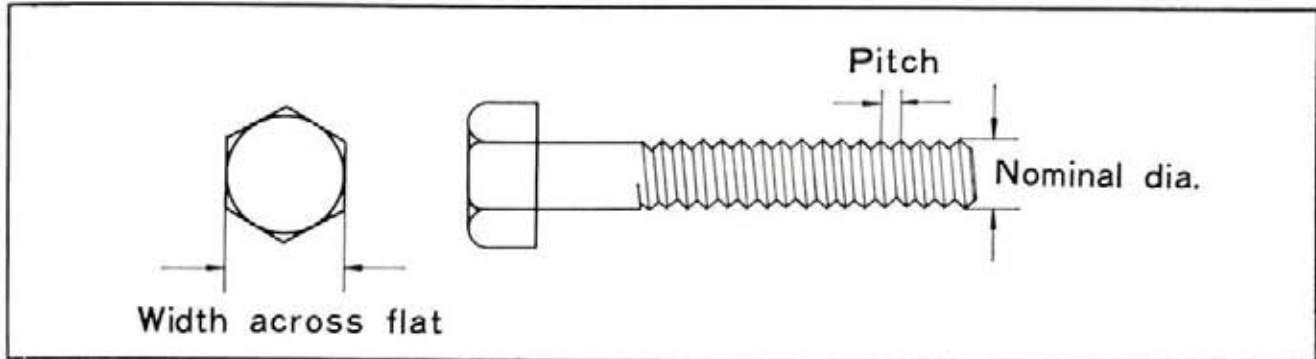


Fig. 1-7

Unit : mm

| Nominal dia | Width across flat | | Pitch | |
|-------------|-----------------------|-----|-------------------------|------|
| | ISO | JIS | ISO | JIS |
| 3 | 5.5 | 6 | 0.5 | 0.6 |
| 4 | 7 | 8 | 0.7 | 0.75 |
| 5 | 8 | 9 | 0.8 | 0.9 |
| 6 | 10 (Same as JIS std.) | 10 | 1.0 (Same as JIS std.) | 1.0 |
| 8 | 12 | 14 | 1.25 (Same as JIS std.) | 1.25 |
| 10 | 14 | 17 | 1.25 (Same as JIS std.) | 1.25 |
| 12 | 17 | 19 | 1.25 | 1.5 |
| 14 | 19 | 21 | 1.5 (Same as JIS std.) | 1.5 |
| 16 | 22 | 23 | 1.5 (Same as JIS std.) | 1.5 |
| 18 | 24 | 26 | 1.5 (Same as JIS std.) | 1.5 |
| 20 | 27 | 29 | 1.5 (Same as JIS std.) | 1.5 |

To make it possible to identify the ISO threads, they are marked as shown below.

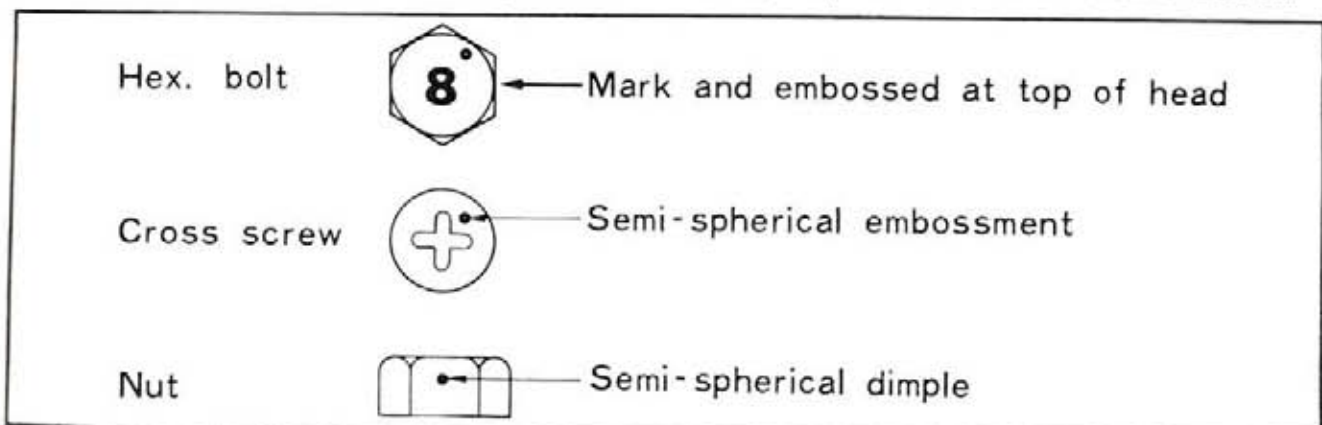
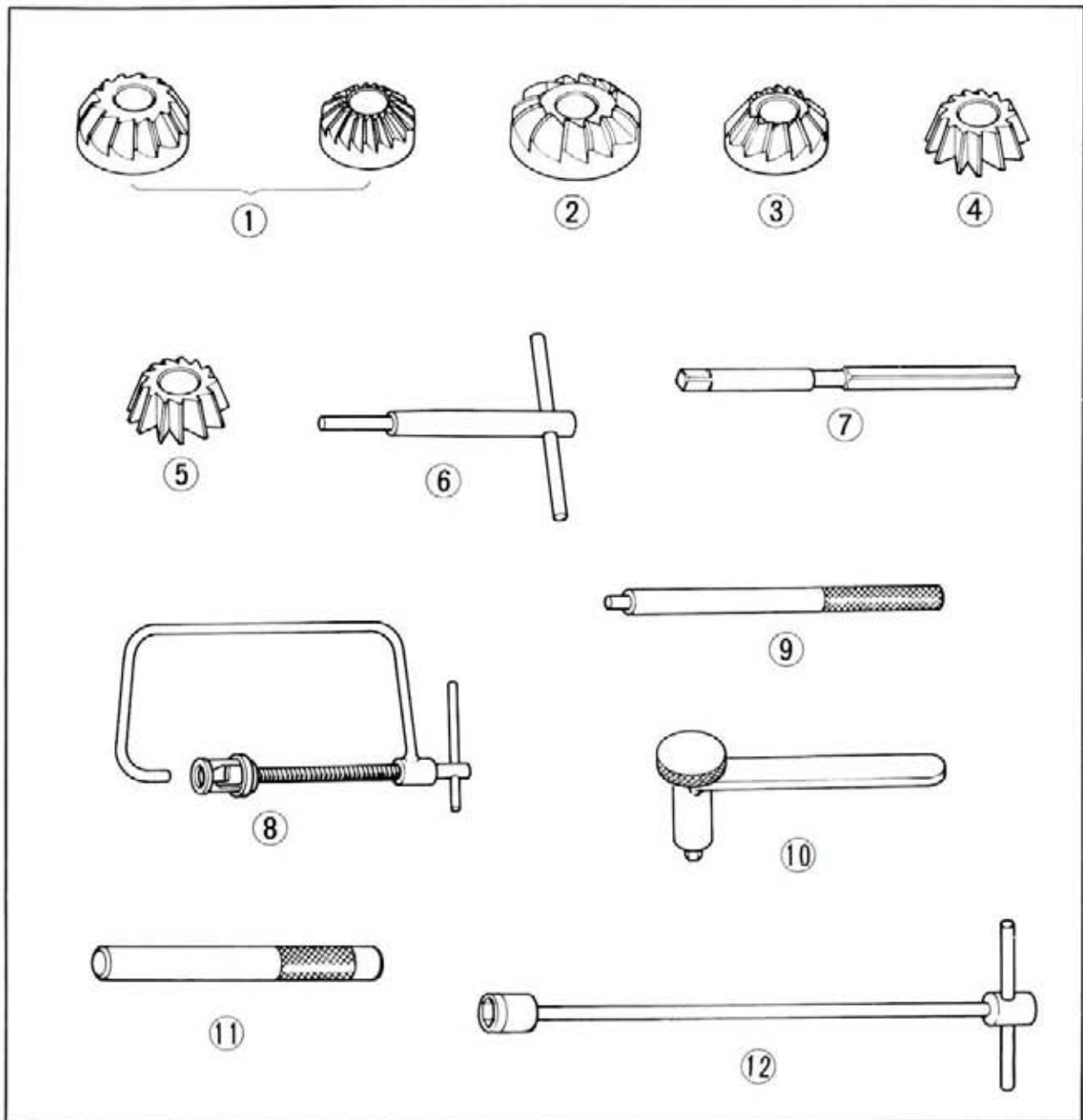
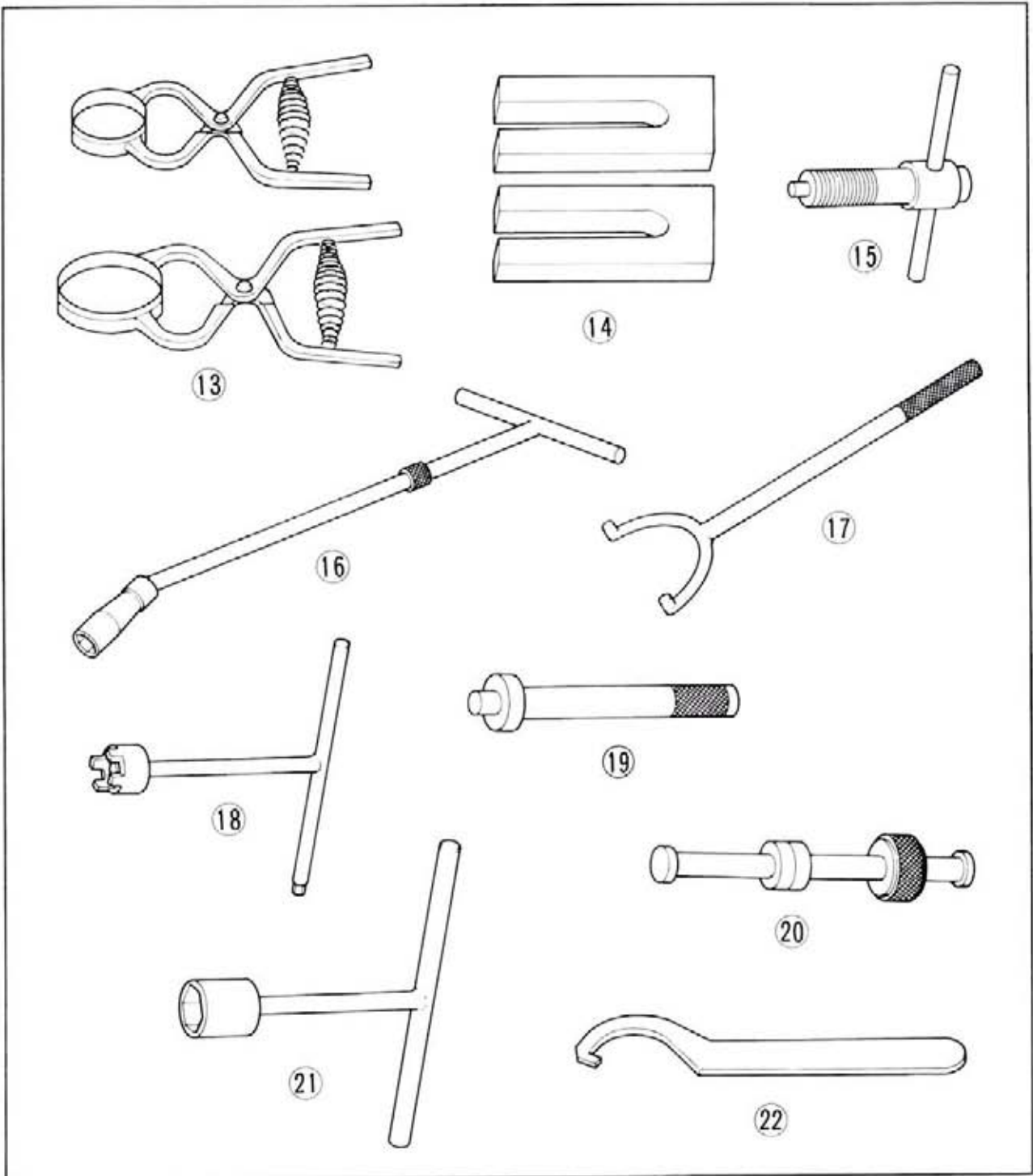


Fig. 1-8

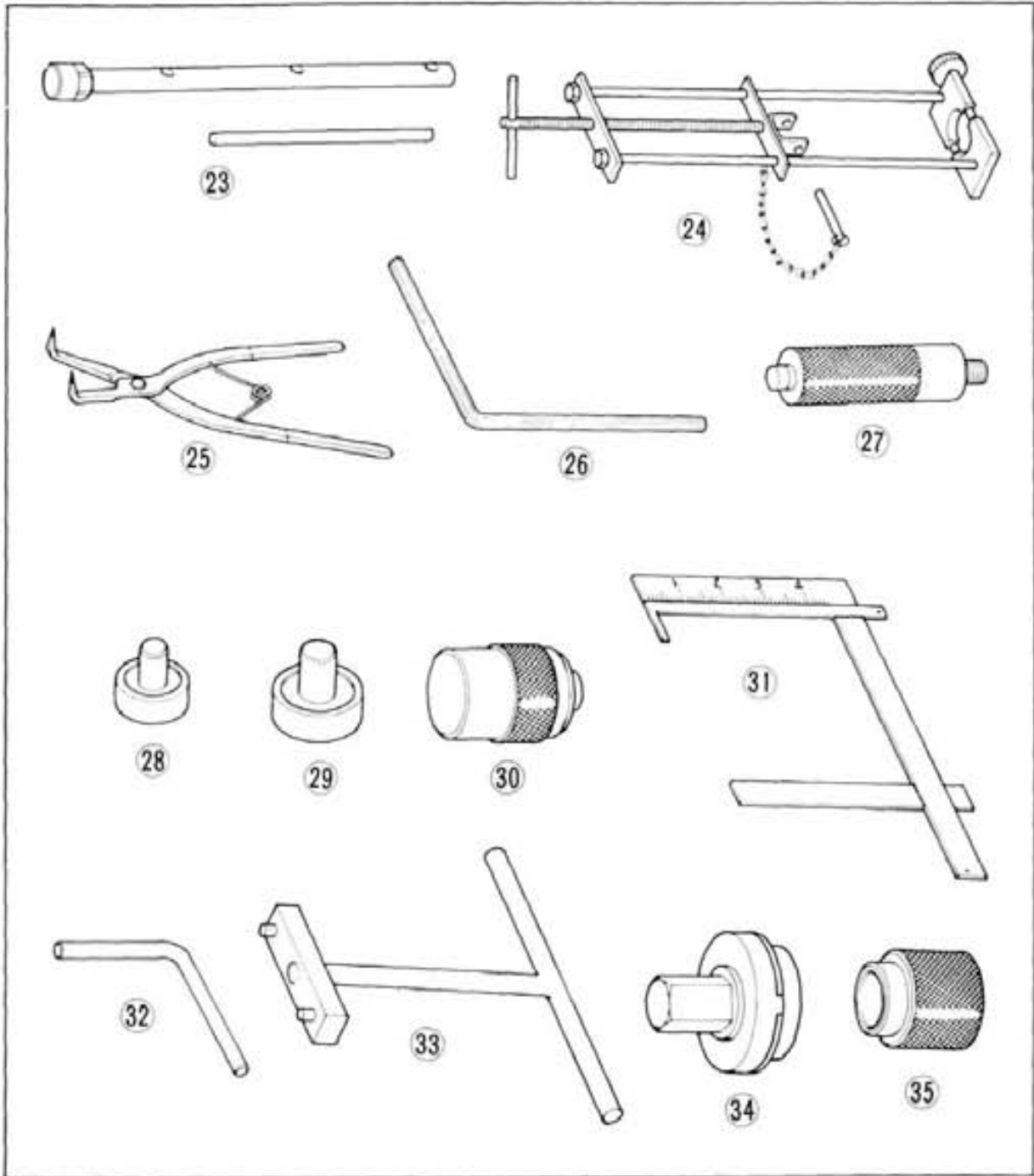
1-5 SERVICE TOOLS



| Ref. No. | TOOL No. | DESCRIPTION |
|----------|---------------|-------------------------------------|
| ① | 07900-3000000 | Special Tool Set for CB 750 |
| ② | 07980-3000100 | Inlet/Exhaust valve seat cutter 90° |
| ③ | 07980-5680400 | Inlet valve seat top cutter |
| ④ | 07980-5510400 | Exhaust valve seat top cutter |
| ⑤ | 07980-5510500 | Inlet valve seat interior cutter |
| ⑥ | 07980-5510500 | Exhaust valve seat interior cutter |
| ⑦ | 07981-5510000 | Valve seat cutter holder |
| ⑧ | 07984-6110000 | Valve guide reamer |
| ⑨ | 07957-3290000 | Valve spring compressor |
| ⑩ | 07942-3000000 | Valve guide driving & removing tool |
| ⑪ | 07908-3230000 | Valve tappet lock nut wrench |
| ⑫ | 07942-3000200 | Valve guide driver |
| | 07906-3230000 | Heat bolt 12 mm wrench |

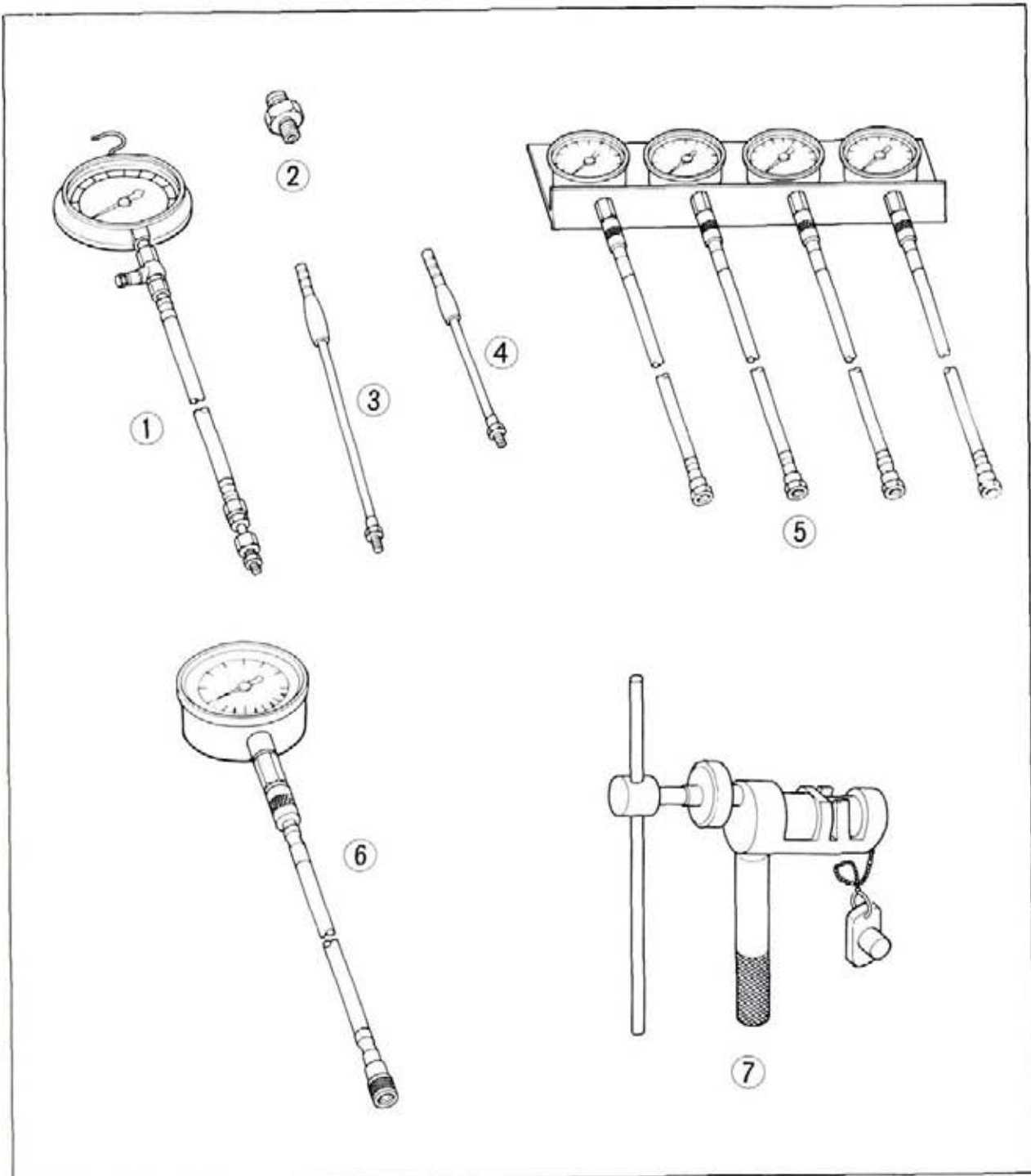


| Ref. No. | TOOL No. | DESCRIPTION |
|----------|---------------|-------------------------------------|
| ⑬ | 07954-3000000 | Piston ring compressor (2 pcs) |
| ⑭ | 07958-3000000 | Piston base (2 pcs) |
| ⑮ | 07933-3000000 | AC generator rotor puller |
| ⑯ | 07909-3000000 | Spark plug wrench |
| ⑰ | 07922-3000000 | Drive sprocket holder |
| ⑱ | 07916-2830000 | Clutch lock nut wrench |
| ⑳ | 07945-3000400 | Counter shaft bearing removing tool |
| ㉑ | 07945-3000500 | Counter shaft bearing removing tool |
| ㉒ | 07915-2160000 | Stem nut box wrench |
| ㉓ | 07902-2000000 | Steering stem top thread wrench |



| Ref. No. | TOOL No. | DESCRIPTION |
|----------|---------------|--|
| 23 | 07967-3000000 | Front fork assembling bar |
| 24 | 07959-3290000 | Rear cushion disassembling & assembling tool |
| 25 | 07914-3230000 | Master cylinder circlip pliers |
| 26 | 07917-3000000 | Hollow set wrench |
| 27 | 07949-3000000 | Bearing driver handle |
| 28 | 07946-3000100 | Front wheel bearing driver |
| 29 | 07946-3000200 | Rear wheel bearing driver |
| 30 | 07945-3000000 | Final drive shaft bearing driver |
| 31 | 07401-0010000 | Carburetor float level gauge |
| 32 | 07999-3000000 | Crankshaft turning handle |
| 33 | 07910-3230101 | Retainer wrench |
| 34 | 07910-2830000 | Retainer wrench |
| 35 | 07947-3290000 | Oil seal guide |

GAUGES AND ATTACHMENT



| Ref. No. | TOOL No. | DESCRIPTION |
|----------|---------------|-------------------------------------|
| ① | 07506-3000000 | Oil pressure gauge (10 kg) |
| ② | 07510-3000000 | Oil pressure gauge adaptor |
| ③ | 07510-3000100 | Vacuum gauge attachment (A) (2 pcs) |
| ④ | 07510-3000200 | Vacuum gauge attachment (B) (2 pcs) |
| ⑤ | 07504-3000100 | Vacuum gauge set (4 pcs) |
| ⑥ | 07504-3000200 | Vacuum gauge (1pcs) |
| ⑦ | 07975-3000001 | Joint tool set |

ENGINE REMOVAL AND INSTALLATION

GROUP
2

CONTENTS

| | |
|-------------------------------|----|
| 2-1 DESCRIPTION | 17 |
| 2-2 ENGINE REMOVAL | 17 |
| 2-3 ENGINE INSTALLATION | 19 |

2-1 DESCRIPTION

The engine is made as single-unit including clutch and transmission and mounted to the frame with four mounting bolts.

The single-unit engine may be dismantled by disconnecting wiring system, fuel system, exhaust system, air intake system and final drive system, and removing engine mounting bolts. However, the following parts can be disassembled from the engine without dismounting the engine from the frame.

Clutch assembly, a.c. generator, cam chain tensioner, gear shift arm, gear shift drum stopper, gear shift positive stopper, contact breaker assembly and carburetor.

2-2 ENGINE REMOVAL

1. Shut off the fuel tank valve and disconnect the fuel tubes from the fuel tank valve. Raise the seat and remove the fuel tank. (refer to page 82).
2. Remove the oil filter and drain the engine oil by removing both the oil tank drain plug (refer to Fig. 15-7 on page 154) and the engine oil drain plug. (Fig. 2-1)
3. Remove the exhaust mufflers.
4. Disconnect the tachometer cable at the cylinder head cover and remove the high tension cord caps from the spark plugs. (Fig. 2-2)
5. After removing the throttle valves from the respective carburetor, detach the carburetors from the inlet pipes.
6. Remove the air cleaner case.
7. Remove the kick starter pedal and the clutch cover.

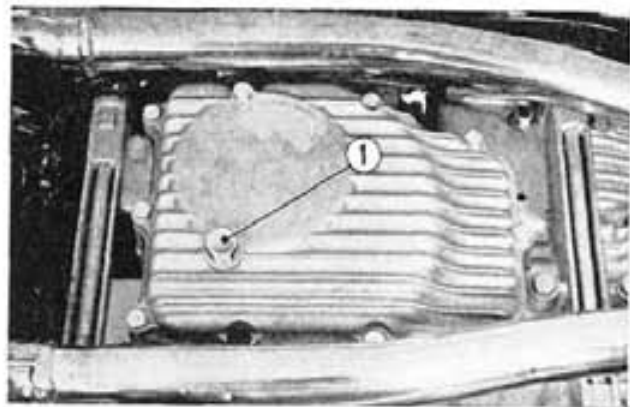


Fig. 2-1 ① Engine oil drain plug

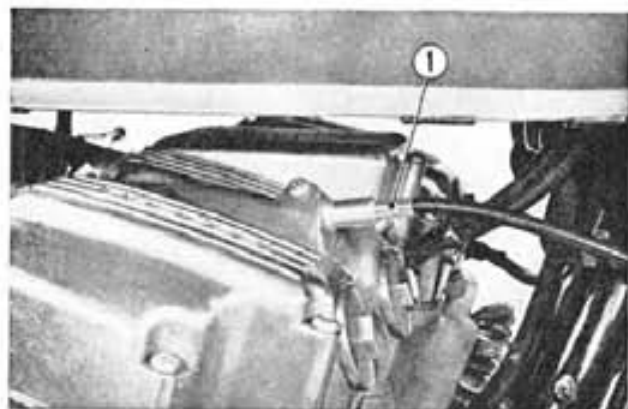


Fig. 2-2 ① Tachometer cable

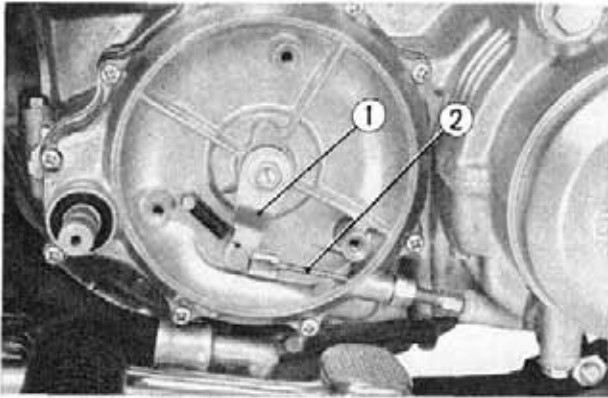


Fig. 2-3 ① Clutch lever
② Clutch cable

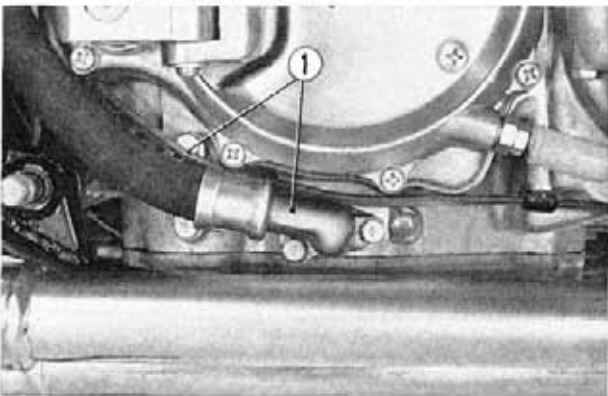


Fig. 2-4 ① Engine oil hoses

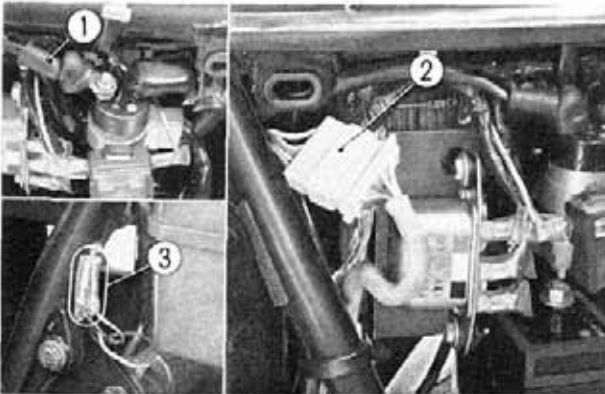


Fig. 2-5 ① Starter motor cable
② Dynamo leads connector
③ Stop switch lead

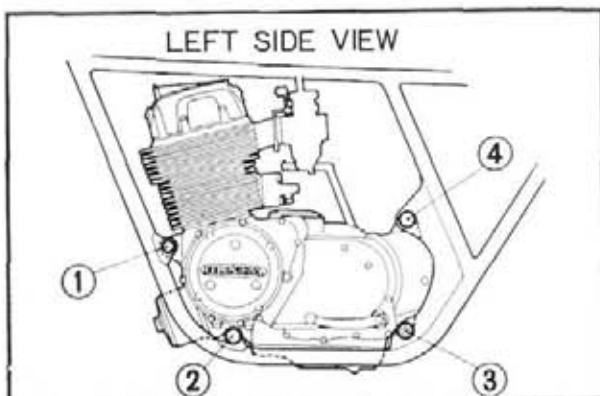


Fig. 2-6 ① 10 mm bolt
② Engine hanger bolt A

8. Disconnect the clutch cable from the clutch lever. (Fig. 2-3)

9. Disconnect the stop switch spring and remove the brake pedal and the step bar.

10. Disconnect the two engine oil hoses at the engine and remove the oil tank. Disconnect the oil tank breather pipe from the upper crankcase. (Fig. 2-4)

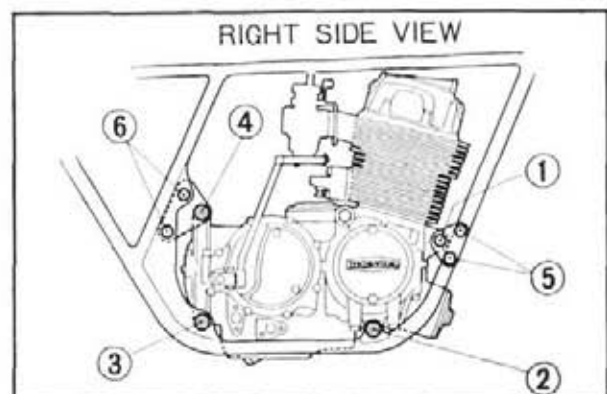
11. Remove the gear change pedal and the drive chain cover and disconnect the drive chain. After disconnecting the chain, the both ends together with a piece of wire to prevent chain from coiling.

12. Disconnect the starter motor cable, dynamo lead connector and the stop switch lead wire. (Fig. 2-5)

Note : Disconnect the starter motor cable at the magnetic switch and disconnect the negative terminal of the battery to prevent accidental shorting.

13. Unscrew the engine hanger bolts and nuts. (Fig. 2-6)

14. Raise the rear of the engine and remove it from the right side.



③ Rear engine hanger lower bolt
④ Engine hanger bolt C

⑤ 8 mm×56 bolt
⑥ 8 mm×45 bolt

2-3 ENGINE INSTALLATION

1. Mount the engine from the right side and position it in the proper location.
2. Install the hanger bolts and nuts and exercise care that the ground cable terminal is installed together with the engine rear upper bolt (Fig. 2-7). The hanger plate and the stop switch stay are also mounted with the hanger bolts.
3. Connect all the wirings and cables.
4. Connect the drive chain, install the drive chain cover and the gear change pedal.
5. Mount the oil tank, install the oil hoses and connect the oil hoses to the engine.
Note: When connecting the oil hoses, make sure that the oil delivery hose and the scavenge hoses are not any crossed.
6. Install the rear brake pedal and connect the stop switch spring (Fig. 2-8)
7. Connect the clutch cable to the clutch lever.
8. Install the clutch pedal and the clutch cover.
9. Mount the carburetors and install the air cleaner case.
10. Connect the throttle valves, the high tension cord caps and the tachometer cable.
11. Observe the installation of the Nos. 1 and 2, and Nos. 3 and 4 muffler bands. Install the exhaust mufflers. (Fig. 2-9)
12. Mount the fuel tank and connect the fuel tubes.
13. Add engine oil into the oil tank. (refer to page 178)

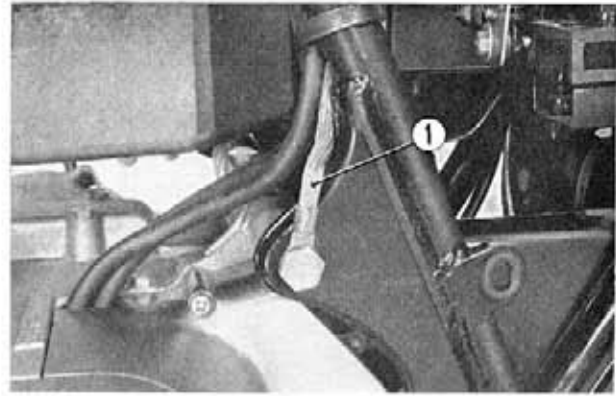


Fig. 2-7 ① Ground cable

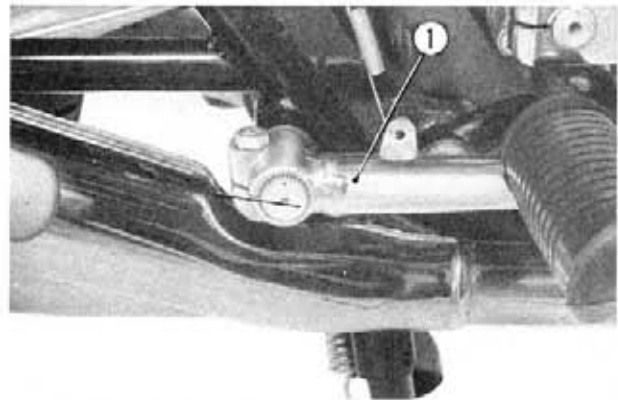


Fig. 2-8 ① Rear brake pedal

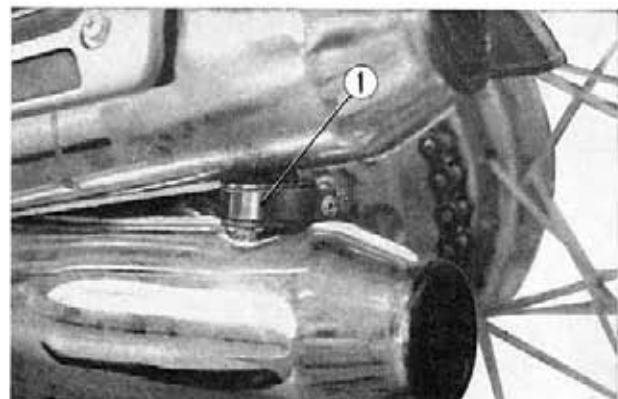


Fig. 2-9 ① Exhaust muffler band

ENGINE MECHANICAL

GROUP

3

CONTENTS

| | |
|--|----|
| 3-1 GENERAL DESCRIPTION | 22 |
| DESCRIPTION | 22 |
| SPECIFICATIONS | 22 |
| DIAGNOSIS | 24 |
| 3-2 LUBRICATION SYSTEM | 26 |
| a. Description | 27 |
| b. Disassembly | 28 |
| c. Inspection | 29 |
| d. Reassembly | 30 |
| 3-3 CAMSHAFT DRIVE | 32 |
| a. Description | 32 |
| b. Disassembly | 32 |
| c. Inspection | 35 |
| d. Reassembly | 36 |
| 3-4 CYLINDER HEAD | 39 |
| a. Description | 39 |
| b. Disassembly | 39 |
| c. Inspection | 39 |
| d. Reassembly | 42 |
| 3-5 PISTON AND CYLINDER | 43 |
| a. Description | 43 |
| b. Disassembly | 43 |
| c. Inspection | 44 |
| d. Reassembly | 45 |
| 3-6 CRANKSHAFT AND CONNECTING ROD | 46 |
| a. Description | 46 |
| b. Disassembly | 46 |
| c. Inspection | 47 |
| d. Reassembly | 50 |
| 3-7 PRIMARY DRIVE | 53 |
| a. Description | 53 |
| b. Disassembly | 53 |
| c. Inspection | 53 |
| d. Reassembly | 54 |
| 3-8 KICK STARTER | 54 |
| a. Description | 54 |
| b. Disassembly | 55 |
| c. Inspection | 55 |
| d. Reassembly | 55 |

3-1 GENERAL DESCRIPTION

DESCRIPTION

HONDA CB750 is a 736 cc, 4-cycle, inline engine incorporating an overhead cam, and mounting 4 carburetors.

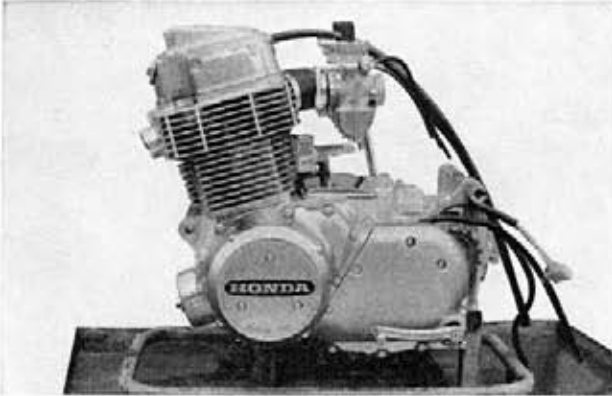


Fig. 3-1 Left side view

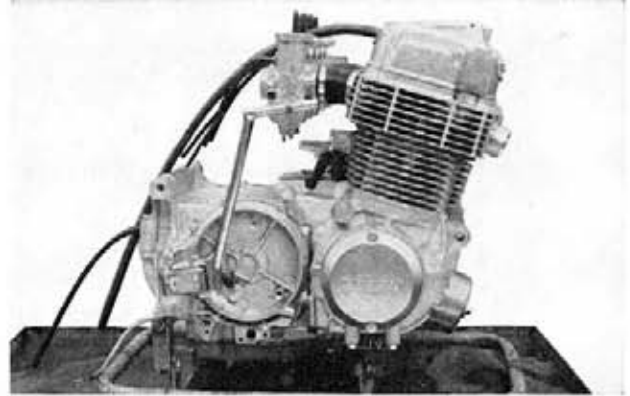


Fig. 3-2 Right side view

SPECIFICATIONS

| | |
|--------------------------|--|
| Type | O.H.C. air-cooled, 4-cycle |
| Cylinder arrangement | 4 cylinders in line |
| Bore and stroke | 2.401×2.480 in. (61×63 mm) |
| Displacement | 44.93 cu-in. (736 cc) |
| Compression ratio | 9.0 : 1 |
| Compression pressure | 170 lbs/in ² (12 kg/cm ²) |
| Valve timing | |
| Inlet valve: open | B.T.D.C. 5° |
| Inlet valve: close | A.B.D.C. 30° |
| Exhaust valve: open | B.B.D.C. 35° |
| Exhaust valve: close | A.T.D.C. 5° |
| Ignition timing B.T.D.C. | 6° at 1,000 rpm, 40° at 2,500 rpm |

| Item | Standard value | Serviceable limit |
|---|---------------------------------------|-------------------------|
| Oil pump | | |
| Body inside diameter | 1.600~1.602 in. 40.65~40.68 mm | 1.6083 in. 40.85 mm |
| Rotor diameter | 1.589~1.600 in. 40.53~40.56 mm | 1.5945 in. 40.50 mm |
| Rotor thickness (delivery side) | 0.7079~0.7087 in. 17.98~18.00 mm | 0.7067 in. 17.95 mm |
| Rotor thickness (scavenge side) | 0.4717~0.4724 in. 11.98~12.00 mm | 0.4705 in. 11.95 mm |
| Body depth (delivery side) | 0.7095~0.7102 in. 18.02~12.04 mm | 0.7114 in. 18.07 mm |
| Body depth (scavenge side) | 0.4732~0.4740 in. 12.02~12.04 mm | 0.4744 in. 12.07 mm |
| Leak stopper valve diameter | 0.7059~0.7067 in. 17.93~17.95 mm | 0.7051 in. 17.91 mm |
| Leak stopper body inner diameter | 0.7087~0.7097 in. 18.00~18.027 mm | 0.7117 in. 18.077 mm |
| Relief valve diameter | 0.4707~0.4718 in. 11.957~11.984 mm | 0.4697 in. 11.93 mm |
| Relief valve body inner diameter | 0.4714~0.4724 in. 11.973~12.00 mm | 0.4736 in. 12.03 mm |
| Camshaft | | |
| Shaft center diameter | 0.8578~0.8587 in. 21.789~21.810 mm | 0.8559 in. 21.74 mm |
| Shaft end diameter | 0.8637~0.8646 in. 21.939~21.960 mm | 0.8628 in. 21.89 mm |
| Base circle | 1.1016~1.103 in. 27.98~28.02 mm | 1.0996 in. 27.93 mm |
| Cam lift (inlet) | 0.3142~0.3158 in. 7.98~8.02 mm | 0.3122 in. 7.93 mm |
| Cam lift (exhaust) | 0.2945~0.2961 in. 7.48~7.52 mm | 0.2925 in. 7.43 mm |
| Camshaft holder | | |
| Camshaft bearing diameter | 0.8669~0.8678 in. 22.02~22.041 mm | 0.8701 in. 22.00 mm |
| Rocker arm bearing diameter | 0.4724~0.4731 in. 12.00~12.018 mm | 0.4744 in. 12.05 mm |
| Rocker arm shaft diameter | 0.4711~0.4718 in. 11.966~11.984 mm | 0.4701 in. 11.94 mm |
| Cylinder head | | |
| Valve guide inner diameter | 0.2598~0.2602 in. 6.60~6.61 mm | 0.2614 in. 6.64 mm |
| Clearance between valve guide and valve stem (IN) | 0.0004~0.0012 in. 0.01~0.03 mm | 0.0032 in. 0.08 mm |
| Clearance between valve guide and valve stem (EX) | 0.0016~0.0024 in. 0.04~0.06 mm | 0.0039 in. 0.1 mm |
| Valve spring | | |
| Free length (outer) | 1.622 in. 41.2 mm | 1.5748 in. 40.0 mm |
| Free length (inner) | 1.500 in. 38.1 mm | 1.4567 in. 37.0 mm |
| Cylinder bore | | |
| Piston diameter | 2.402~2.4024 in. 61.01~61.02 mm | 2.4055 in. 61.1 mm |
| Piston pin bore diameter | 0.5906~0.5909 in. 15.002~15.008 mm | 0.5937 in. 15.08 mm |
| Piston pin diameter | 0.5903~0.5906 in. 14.994~15.00 mm | 0.589 in. 14.96 mm |

| Item | Standard value | Serviceable limit |
|--------------------------------------|---------------------------------------|----------------------------------|
| Piston ring | | |
| Ring side clearance (top) | 0.0016~0.0028 in. 0.04~0.07 mm | 0.0071 in. 0.18 mm |
| Ring side clearance (second) | 0.001~0.0022 in. 0.025~0.055 mm | 0.0065 in. 0.165 mm |
| Ring side clearance (oil) | 0.0004~0.0016 in. 0.010~0.04 mm | 0.0055 in. 0.14 mm |
| End gap (top and second) | 0.0079~0.016 in. 0.2~0.4 mm | 0.0028 in. 0.7 mm |
| End gap (oil) | 0.0004~0.0012 in. 0.1~0.3 mm | 0.0028 in. 0.7 mm |
| Crankshaft | | |
| Journal diameter | 1.4169~1.4173 in. 35.99~36.00 mm | 1.415 in. 35.94 mm |
| Crank pin diameter | 1.4169~1.4173 in. 35.99~36.00 mm | 1.415 in. 35.94 mm |
| Shaft to bearing clearance | 0.0008~0.0018 in. 0.02~0.046 mm | 0.0032 in. 0.08 mm |
| Connecting rod | | |
| Small end diameter | 0.5912~0.5919 in. 15.016~15.034 mm | 0.5933 in. 15.07 mm |
| Bearing oil clearance | 0.0008~0.0018 in. 0.02~0.046 mm | 0.0032 in. 0.08 mm |
| Large end diameter | Select fit, refer to page 43~44. | Select fit, refer to page 43~44. |
| Number of teeth of kick starter gear | 63 teeth | — |
| Kick starter gear | | |
| Inner diameter | 0.7866~0.789 in. 19.98~20.041 mm | 0.790 in. 20.075 mm |
| Shaft outer diameter | 0.7853~0.7866 in. 19.959~19.98 mm | 0.7847 in. 19.93 mm |

DIAGNOSIS

| Trouble | Probable Causes | Remedy |
|------------------------------|--|--|
| Engine does not start | Valve Mechanism <ol style="list-style-type: none"> Excessive by worn piston ring and cylinder Seized valve Seized piston Valve timing out of adjustment Low or lack of compression pressure <ul style="list-style-type: none"> Pressure leak Defective cylinder head gasket Warped gasketing surface of the cylinder and cylinder head | Replace. Replace. Replace. Adjust, (Refer to page 31~32). Grind the valve to obtain good valve seating or replace. Replace. Repair or replace. |



| Trouble | Probable Causes | Remedy |
|--|---|--|
| Poor engine idling | Valve Mechanism 1. Improper valve tappet clearance 2. Low or lack of compression pressure 3. Excessive valve guide clearance | Adjust to standard value, (Refer to page 36~37). Repair. Replace valve and guide. |
| Loss of power | 1. Valve sticking open 2. Poor valve sealing 3. Weak or broken valve spring 4. Improper valve timing 5. Defective cylinder head gasket 6. Worn cylinder and piston 7. Worn, weak or broken piston ring 8. Loose spark plug | Replace Re grind valve (Refer to page 34). Replace (Refer to page 34~35) Check valve timing and adjust if necessary (Refer to page 36~37) Replace (Refer to page 35). Replace (Refer to page 38). Replace (Refer to page 38~39). Retighten. |
| Over heating | 1. Heavy carbon deposit on combustion chamber and piston head 2. Lean fuel mixture 3. Retarded ignition timing 4. Low oil level, poor quality 5. Extended operation in low gear | Remove carbon (Refer to page 35 and 38). Adjust the carburetor. Adjust ignition timing (Refer to page 83~84). Add good grade oil. |
| Back fire | 1. Poor sealing of the inlet valve 2. Improper valve timing 3. Improper ignition timing 4. Excessively large spark plug gap 5. Inadequate fuel supply | Check the valve seating Adjust (Refer to page 36~37). Adjust (Refer to page 83~84). Adjust the gap to 0.024~0.028 in. (0.6~0.7 mm). |
| White exhaust smoke | 1. Excessive wear of cylinder and piston 2. Overfilled engine oil 3. Excessively high oil pressure 4. Poor quality oil | Replace the piston (Refer to page 38). Adjust the oil level. Replace with good quality oil. |
| Black exhaust smoke | Rich fuel mixture | Adjust the carburetor (Refer to page 70~71). |
| Pedal does not return | 1. Defective return spring 2. Unhook return spring | Replace Hook return spring |
| Kick starter gear does not rotate | 1. Worn kick stater pawl | Replace |

3-2 LUBRICATION SYSTEM

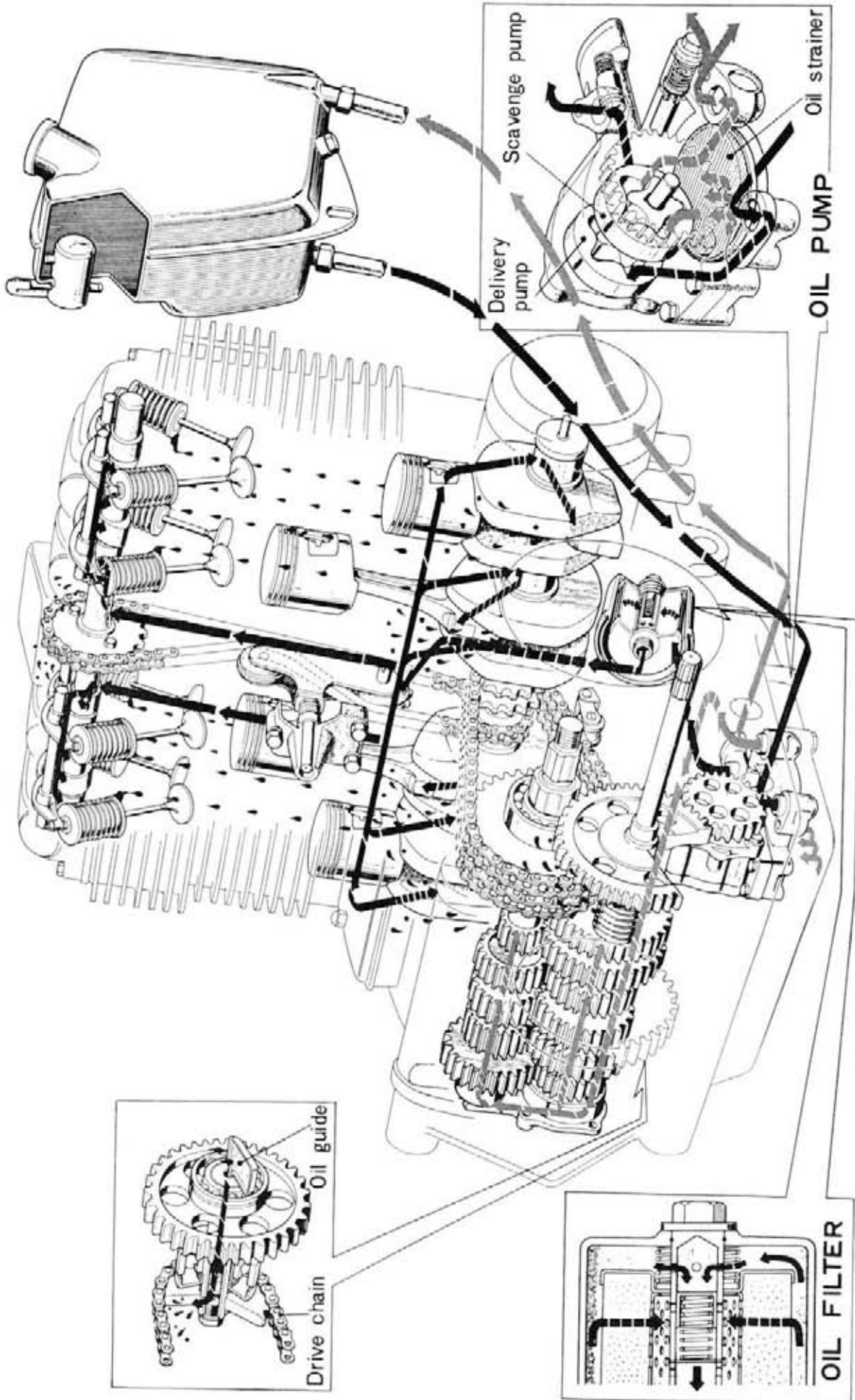


Fig. 3-3

a. Description

The engine is a dry sump type incorporating a separate oil tank which is mounted on the right side of the frame. The oil in the tank is delivered under pressure by the oil pump to lubricate the engine components. The oil accumulated in the crankcase sump is returned to the oil tank by the scavenge pump, however, part of the oil is diverted to lubricate transmission components.

1. Oil pump

The oil pump is a rotor type trochoid pump mounted on the bottom of the crankcase and driven from the primary shaft through the kick gear. It consists of both the delivery and scavenge pumps, a leak stopper valve and a relief valve. (Fig. 3-4)

(Oil leak stopper valve)
During engine operation, the oil pressure opens the oil leak stopper valve to maintain oil flow, and when the engine stops, the valve closes to prevent flow from the oil tank. (Fig. 3-5)

(Relief valve)

Relief valve is set at a specified pressure so that whenever the oil pressure exceeds this pressure, the valve opens and bypasses the oil to crankcase sump. In this way, the constant oil pressure is maintained.

This valve is incorporated in the delivery side of the oil pump. (Fig. 3-6)

Standard valve setting is 56.9lbs/in.² (4.0 ± 0.2 kg/cm²) at 4,000 rpm engine speed at oil temperature of 176°F (80°C).

2. Oil filter

Oil filter is a full flow type using a replaceable element filter.

All the oil from the oil pump passes

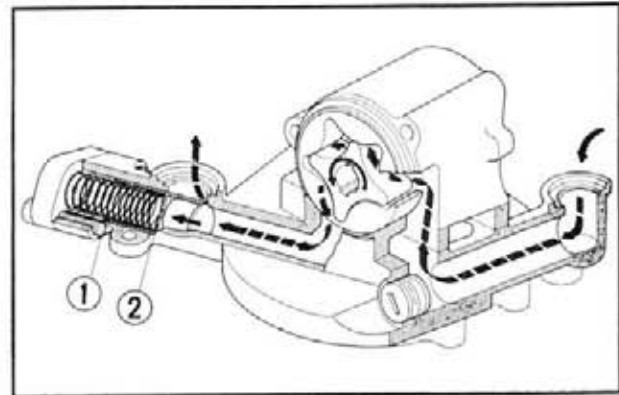


Fig. 3-5 ① Oil leak stopper spring
② Oil leak stopper valve

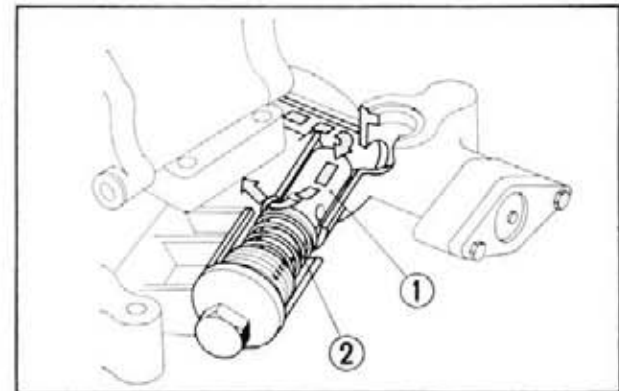


Fig. 3-6 ① Relief valve
② Relief valve spring

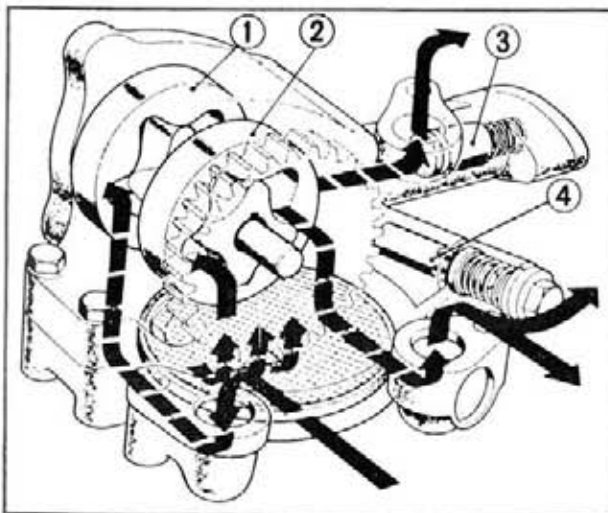


Fig. 3-4 ① Delivery pump
② Scavenge pump
③ Leak stopper valve
④ Relief valve

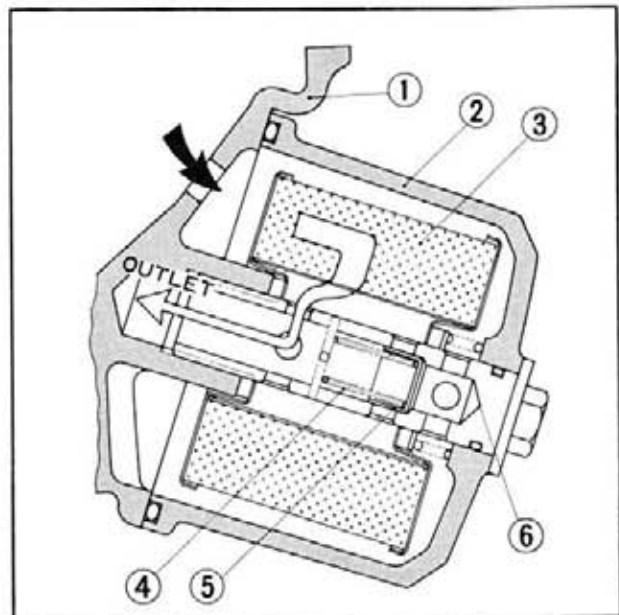


Fig. 3-7 ① Crankcase ④ By-pass valve spring
② Oil filter case ⑤ By-pass valve
③ Oil filter element ⑥ Center bolt

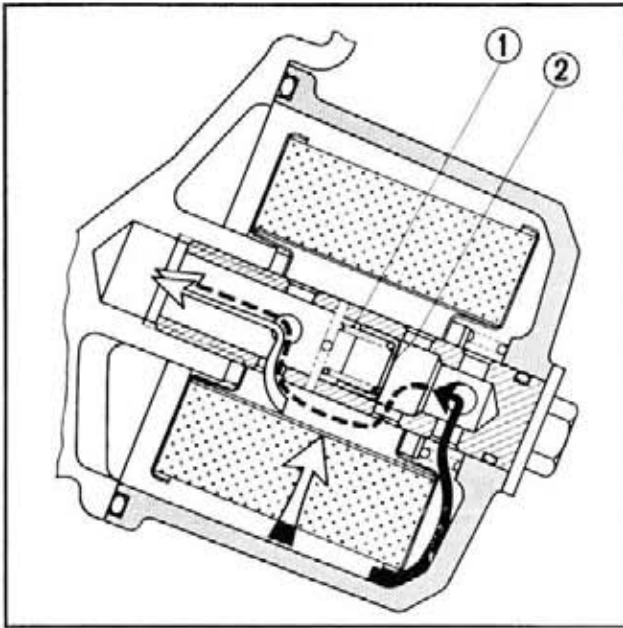


Fig. 3-8 ① By-pass valve spring
② By-pass valve

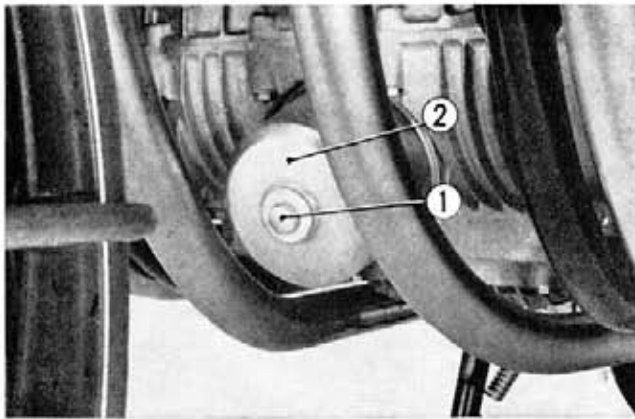


Fig. 3-9 ① Oil filter center bolt
② Oil filter case

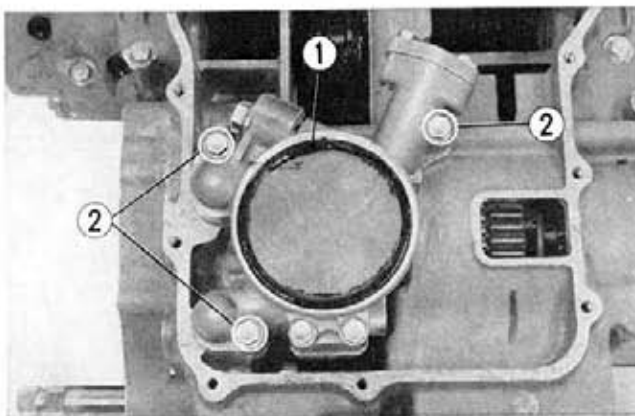


Fig. 3-10 ① Oil pump
② Oil pump mounting bolts

through the filter to be purified before being sent to the crankshaft. Filter assembly is mounted at the front of the engine with a bolt. Further, a by-pass valve is incorporated in the bolt to prevent oil stoppage when the element becomes clogged. (Fig. 3-7)

(By-pass valve)

When the element becomes clogged and the oil pump discharge pressure rises excessively, the by-pass valve opens and the oil will by-pass the filter element and flow directly into the main gallery. At $21.3 \pm 2.8 \text{ lbs/in}^2$ ($1.5 \pm 0.2 \text{ kg/cm}^2$) pressure difference, the valve is functioned. (Fig. 3-8)

3. Oil pressure warning lamp

The red oil pressure warning lamp is located to the left side of the tachometer on the gauge. Normally the light will be on when the engine is stopped and the main key switch is turned on. However, it will go off as soon as the engine is started and oil pressure reaches 7.1 lbs/in^2 (0.5 kg/cm^2).

If the warning light came on while riding the engine should be stopped and the cause of the problem determined.

When operating the engine under extremely high oil temperature (over 244°F , 100°C), the warning light may intermittently come on at idling speed (800~900 rpm), however, this does not indicate a problem.

4. Drive chain lubrication

The drive chain is automatically lubricated by the chain oiler equipped on the drive shaft.

The oil which is soaked into the felt oil reserve element located at the end of the drilled passage in the final drive shaft leaks out along the face of the drive sprocket by the centrifugal force to lubricate the chain.

b. Disassembly

The oil pump can be removed with the engine mounted on the frame.

1. Unscrew the oil filter center bolt from the front of the engine and take out the oil filter case. (Fig. 3-9)
2. Remove the oil pan from the lower crankcase to get access to the oil pump.
3. Unscrew the three oil pump mounting bolts and remove the oil pump. (Fig. 3-10)

4. To remove the oil pump rotors, disassemble the side cover and remove the rotor A, (delivery side); next, remove the dowel pin and pull out the shaft from the rotor body. This will permit the rotor B (scavenge side) to be removed. (Fig. 3-11)

5. Remove the metal oil screen and unscrew the four bolts at the pump base to remove the oil pump body. (Fig. 3-12)

6. For disassembling the oil leak stopper valve, remove the oil leak stopper cap bolts. The oil leak stopper cap, spring and oil leak stopper valve can be removed from the oil pump. (Fig. 3-13)

7. For disassembling the relief valve, unscrew the relief spring cap, the relief valve spring and relief valve can be removed. (Fig. 3-13)

c. Inspection

1. Check the oil pump side cover for cracks.

2. Outer rotor and body clearance

Measure the clearance between the outer rotor and the body with a thickness gauge. If the clearance between rotor and body is greater than **0.0138 in. (0.35 mm)**, the rotor or the body should be replaced, depending on which part is worn. (Fig. 3-14)

3. Measuring the tip clearance

Measure the clearance between the outer rotor and the inner rotor with a thickness gauge and if it is greater than **0.0138 in. (0.35 mm)**, the rotors should be replaced in set. (Fig. 3-15)

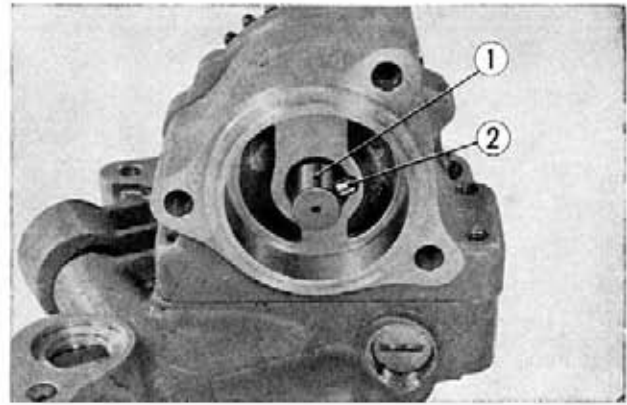


Fig. 3-11 ① Oil pump rotor shaft
② Dowel pin

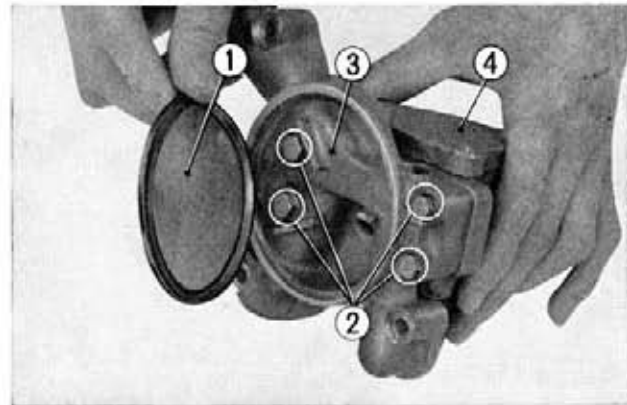


Fig. 3-12 ① Metal oil screen ③ Oil pump base
② 6 mm hex bolts ④ Oil pump body

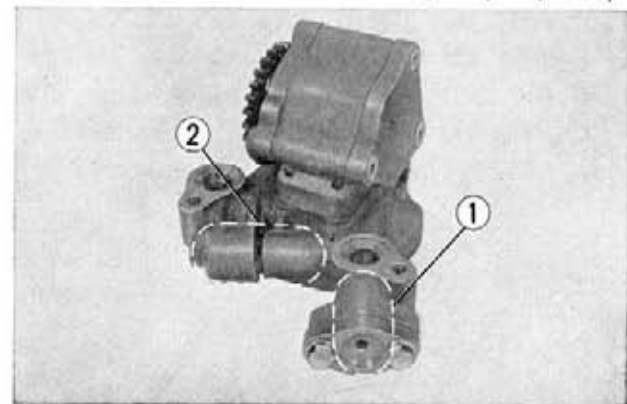


Fig. 3-13 ① Leak stopper valve
② Relief valve

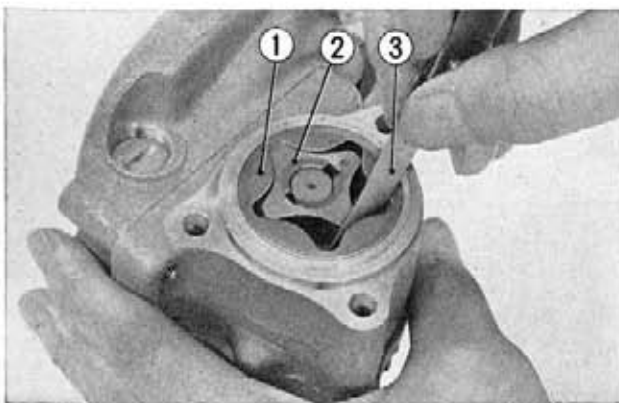


Fig. 3-15 ① Outer rotor ③ Thickness gauge
② Inner rotor

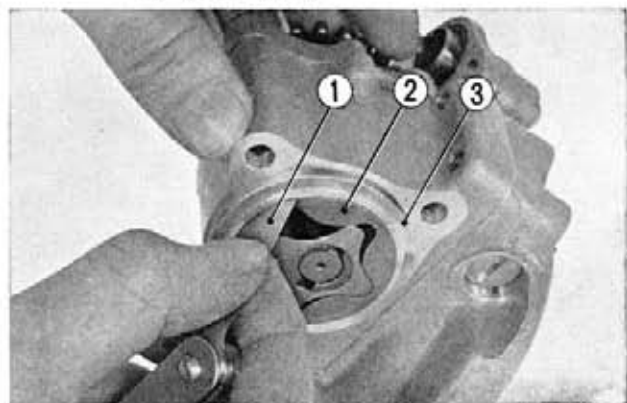


Fig. 3-14 ① Thickness gauge ③ Pump body
② Outer rotor

4. Measuring the leak stopper valve clearance
Measure the body inside diameter and the leak stopper valve outside diameter using a dial gauge or a micrometer and if the clearance is calculated to be greater than **0.0067 in. (0.17 mm)**, the leak stopper valve or body whichever is worn beyond serviceable limit should be replaced.

5. Measuring the relief valve clearance
Measure the body inside diameter and the relief valve diameter using a dial gauge or a micrometer and if the clearance is greater than **0.0039 in. (0.1 mm)**, the body or the valve whichever is beyond serviceable limit should be replaced.

6. Measuring the rotor thickness and the body clearance

Measure the rotor thickness with a micrometer and the depth using the depth micrometer and if the clearance is greater than **0.0047 in. (0.12 mm)**, the parts should be repaired or replaced.

7. Cleaning oil strainer

Wash the oil strainer in clean solvent. Be sure to replace the oil strainer with a new one if damaged. (Fig. 3-16)

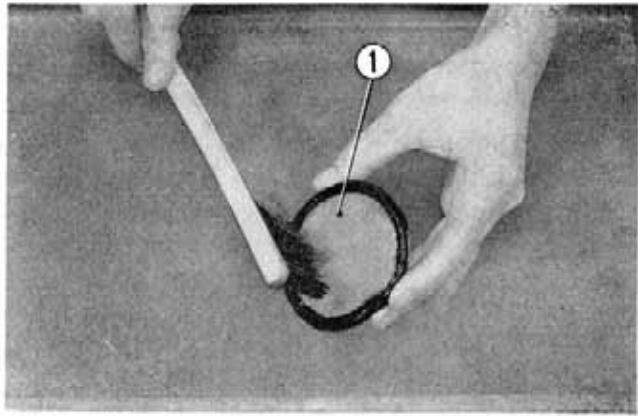
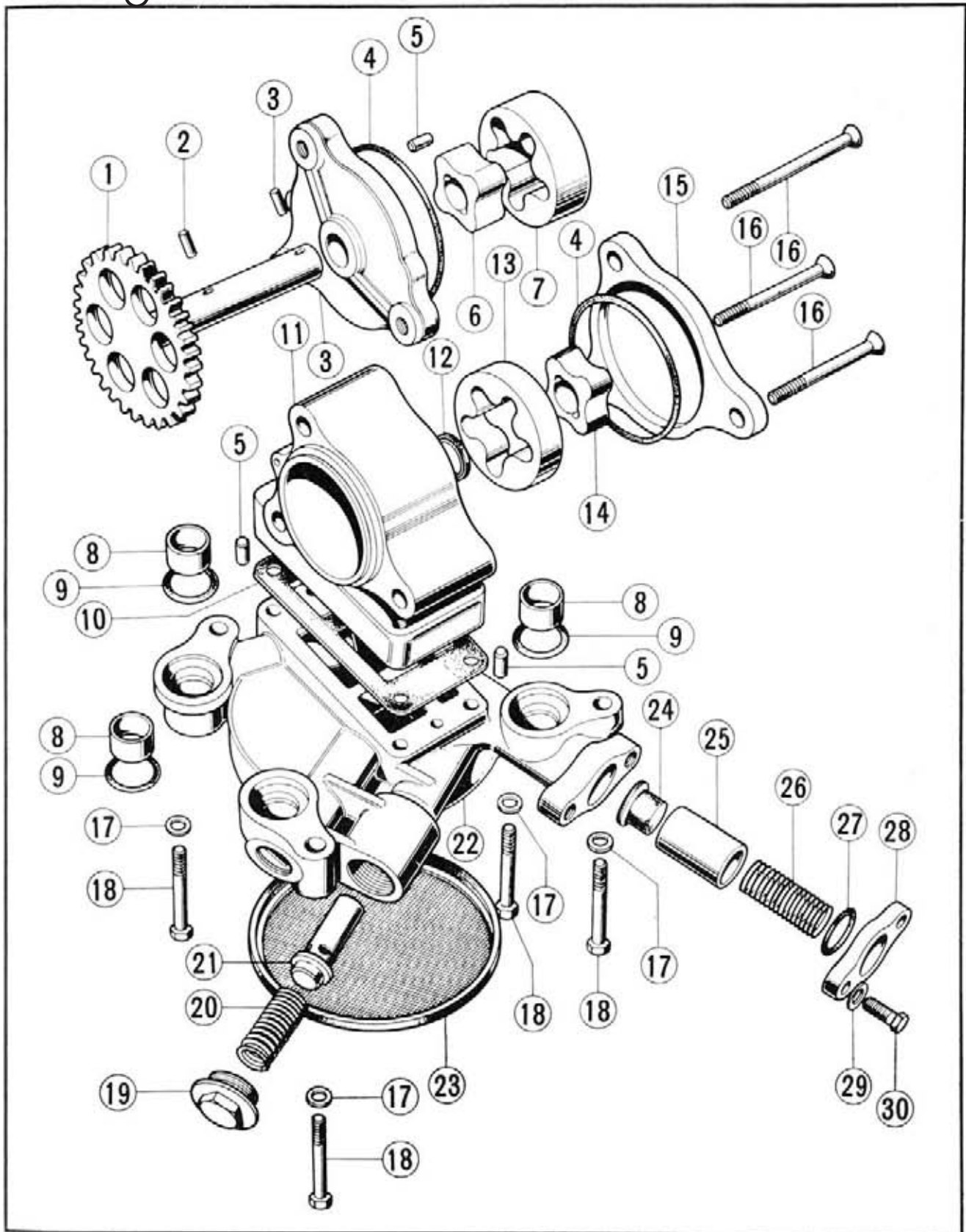


Fig. 3-16 Oil strainer

d. Reassembly

1. Assemble the oil pump component parts in accordance with Fig. 3-17. Assemble the relief valve, relief valve spring and screw the relief spring cap securely.
2. Assemble the oil leak stopper valve, spring, O ring and oil leak stopper cap, and then tighten the two bolts.
3. Mount the inner and outer rotors B into the oil pump body, and insert the oil pump drive gear. Do not forget to install the rotor dowel pin.
4. Mount the inner and outer rotors A into the pump body.



- ① Oil pump drive gear
- ② 4×14.8mm pin
- ③ Oil pump right cover
- ④ 46×2 "O" ring
- ⑤ 4×8 dowel pin
- ⑥ Inner rotor B
- ⑦ Outer rotor B
- ⑧ "O" ring collar
- ⑨ 15×2.5 "O" ring
- ⑩ Oil pump gasket

- ⑪ Oil pump body
- ⑫ 11×15×3 Oil seal
- ⑬ Outer rotor A
- ⑭ Inner rotor A
- ⑮ Oil pump left cover
- ⑯ 6×59 flat screw
- ⑰ 6mm flat washer
- ⑱ 6×32 hex bolt
- ⑲ Relief spring cap
- ⑳ Relief valve spring

- ㉑ Relief valve
- ㉒ Oil pump base
- ㉓ Oil strainer screen
- ㉔ Oil leak stopper seal
- ㉕ Oil leak stopper valve
- ㉖ Oil leak stopper spring
- ㉗ 15×2.5 "O" ring
- ㉘ Oil leak stopper cap
- ㉙ 6mm flat washer
- ㉚ 6mm hex bolt

Fig. 3-17

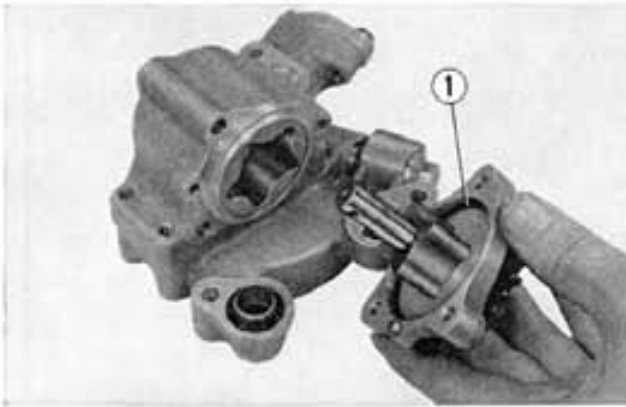
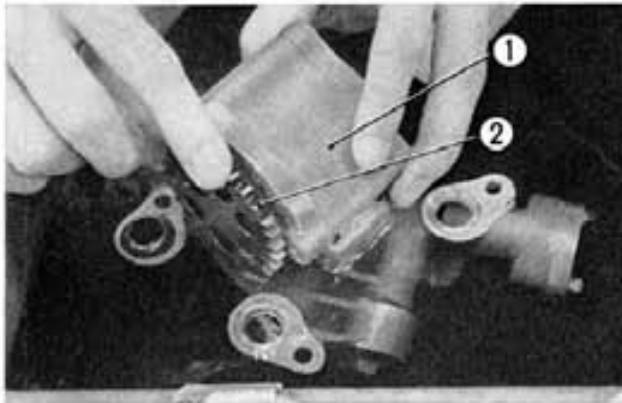


Fig. 3-18 ① "O" ring

- Note:** Do not forget to install the O-ring on the side cover. (Fig. 3-18)
5. After completing the assembly of the rotor, turn the shaft by hand to assure that it is turning smoothly.

Fig. 3-19 ① Oil pump assembly
② Oil pump drive gear

6. Immerse the pump in oil and turn the pump until filled with oil before reinstalling the pump on the crankcase. (Fig. 3-19)
7. When reinstalling the oil pump on the crankcase, do not forget to install the oil guide pins (3 each) and the O-ring (3 each).
8. Changing oil and filter element procedures should be referred to group 19 on page 178.

3-3 CAMSHAFT DRIVE

a. Description

The camshaft is supported at the four points by two aluminum alloy camshaft holders and driven by an endless chain off the timing sprocket located at the center of the crankshaft.

The cam chain is guided by an adjustable cam chain tensioner, a guide roller and a cam chain guide. (Fig. 3-20)

b. Disassembly

1. Unscrew the three 6 mm cross screws and remove the breather cover. (Fig. 3-21)
2. Loosen the 6 mm cross screws and remove the cylinder head cover. (Fig. 3-22)

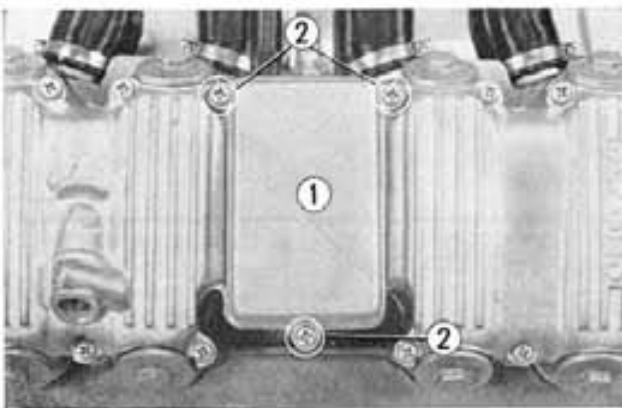
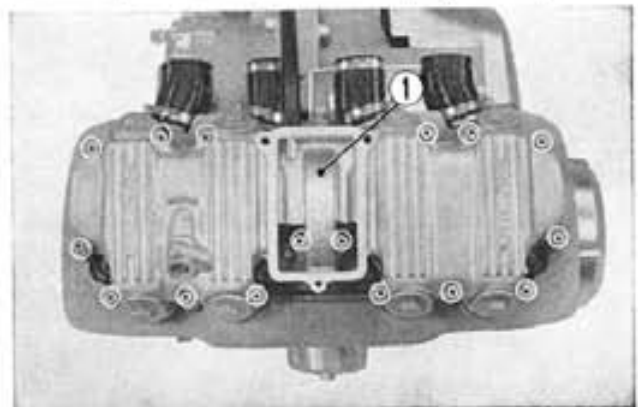
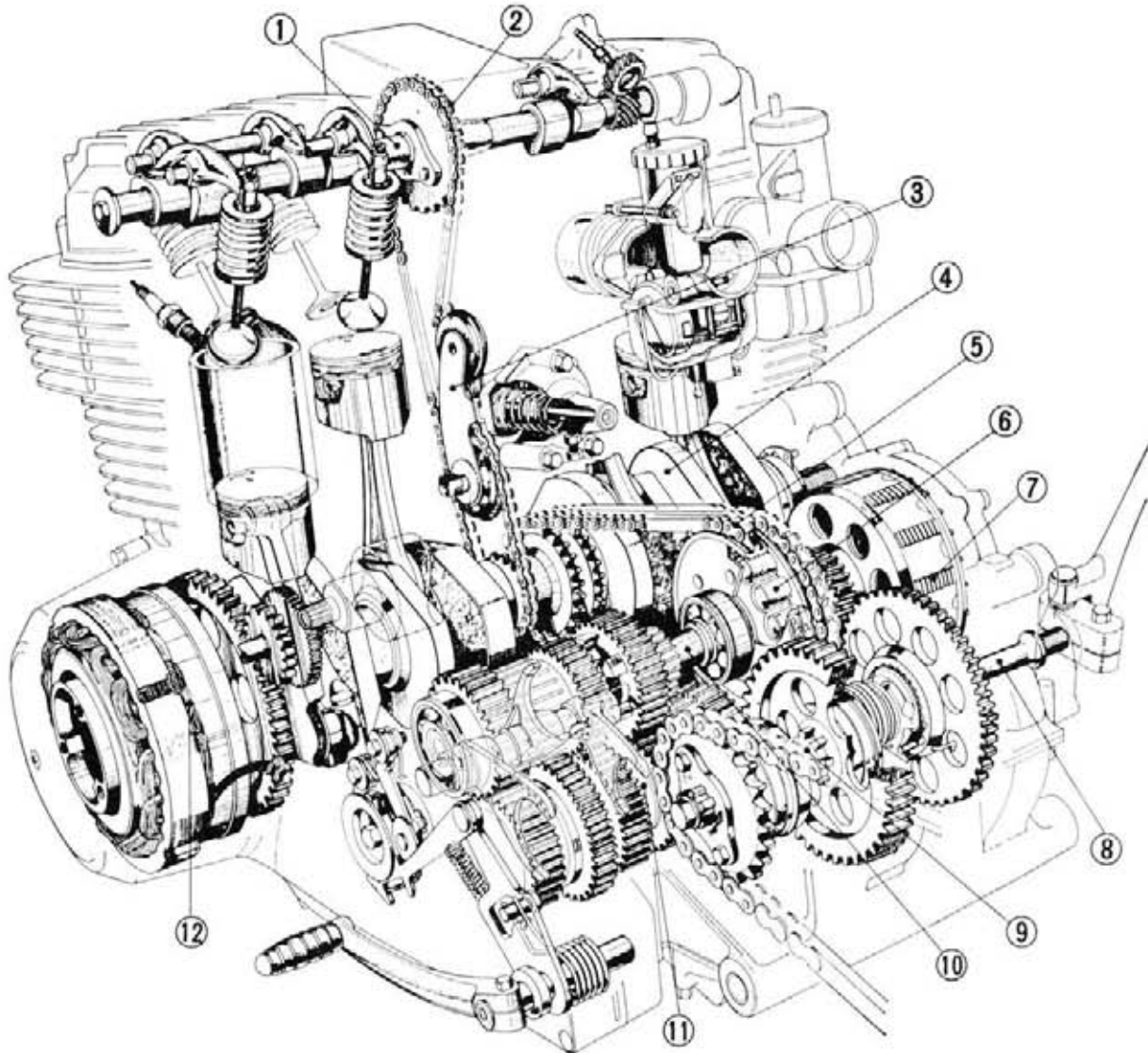
Fig. 3-21 ① Breather cover
② Cross screws

Fig. 3-22 ① Cylinder head cover



- | | |
|---------------------------|------------------------|
| ① Camshaft | ⑦ Clutch |
| ② Camchain | ⑧ Kick starter spindle |
| ③ Camchain tensioner | ⑨ Final driven shaft |
| ④ Crankshaft | ⑩ Mainshaft |
| ⑤ Primary chain | ⑪ Countershaft |
| ⑥ Primary driven sprocket | ⑫ A.C. generator |

Fig. 3-20

3. Turn the crankshaft to align the timing index line (on the tachometer gear end) so that it is parallel with the cylinder head mating surface (with the key groove toward the top) and then remove the camshaft holder cap. (Fig. 3-23)

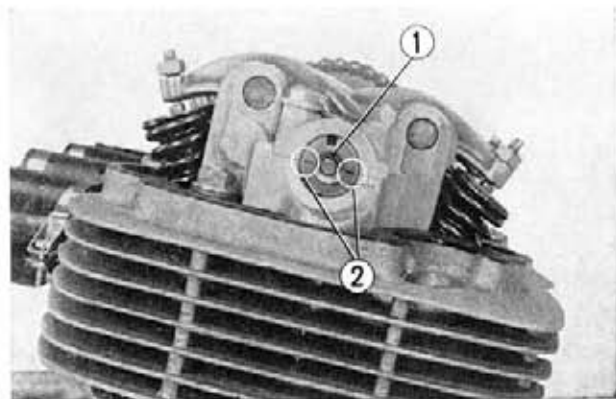


Fig. 3-23 ① Camshaft
② Timing index marked lines

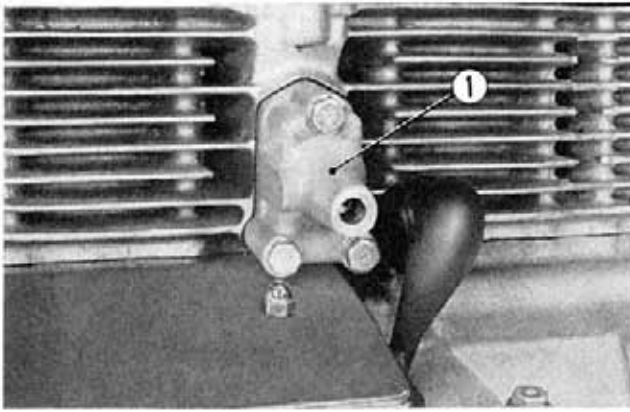


Fig. 3-24 ① Cam chain tensioner holder

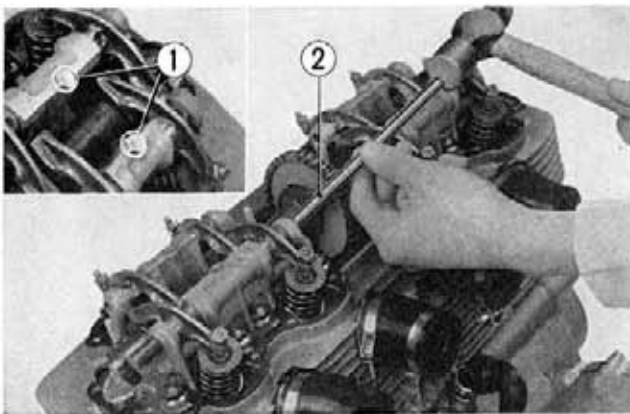


Fig. 3-25 ① Rocker arm shaft mounting bolts
② Rocker arm shaft remover

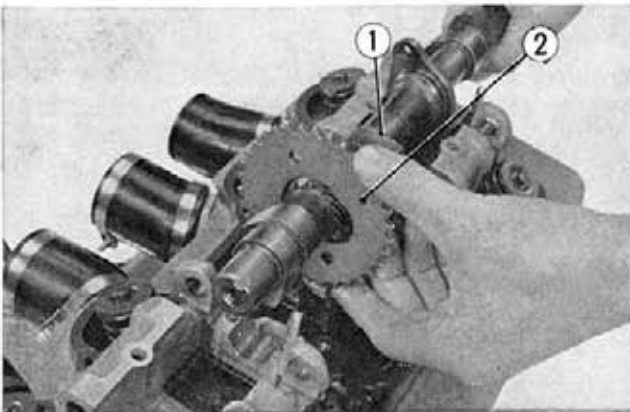


Fig. 3-26 ① Camshaft
② Cam sprocket

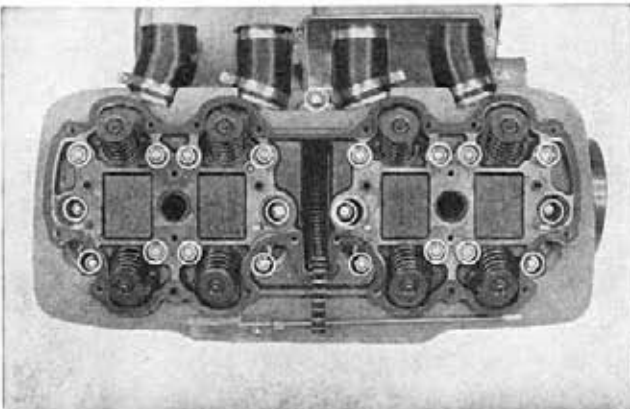


Fig. 3-27 Removing cylinder head mounting nuts and bolts

4. Detach the cam chain tensioner holder from the cylinder. (Fig. 3-24)

5. Unscrew the two cam sprocket mounting bolts and then loosen the valve tappet adjusting screws. Unscrew the four rocker arm shaft mounting bolts and pull out the rocker arm shaft using the rocker arm shaft remover (Tool No. 07050-30001) being careful not to damage the holder. (Fig. 3-25)

Note: Rocker arm No. 1 and No. 3, and rocker No. 2 and No. 4 are identical, therefore, tag the respective rocker arms for identification.

6. Remove the cam chain from the cam sprocket and then pull out the camshaft from the camshaft holder at the left side. (Fig. 3-26).

7. Detach the camshaft holder from the cylinder head.

8. Remove the sixteen cylinder head mounting nuts, the five 6 mm mounting bolts and then separate the cylinder head from the cylinder. Use a special tool (Tool No. 07906-3230000) to loosen the 6 mm mounting bolts on both sides. Loosening sequence of the mounting nuts is performed in the reverse sequence indicated Fig. 3-38 on page 67. (Fig. 3-27)

9. Remove the cylinder from the crankcase.

10. Remove the two cam chain tensioner mounting rubbers from the crankcase and then remove the cam chain tensioner roller assembly. (Fig. 5-28)
11. Cam chain guide roller can be removed from the cam chain tensioner by pushing the cam chain roller pin.
12. Remove the cam chain guide pin from the bottom of the cylinder and remove the cam chain guide from the cylinder. (Fig. 3-29)

c. Inspection

1. Measuring the camshaft clearance
(Perform the measurement with a micrometer and inside dial gauge)
 - a. Assemble the camshaft holder on the cylinder head and assemble the cap on the camshaft holder making sure that the cap and holder are stamped with the identical markings.
Torque to 6.0~8.0 ft. lbs (80~110 kg-cm)
 - b. Measure the bearing inside diameter in both the vertical and horizontal direction using the inside dial gauge and calculate the average value. Next, measure the camshaft bearing with a micrometer and then compute the shaft clearance. If the clearance is greater than **0.0083 in. (0.21 mm)**, the camshaft holder and the cap should be replaced in set. Further, the clearance may be measured using a press gauge. (Fig. 5-30, 31)
2. Measuring the cam lift

The camshaft lift is checked by measuring the height of the camshaft from the bottom of base circle. If the total height for the inlet cam is less than **1.411 in. (35.86 mm)**, and for the exhaust, **1.392 in. (35.36 mm)** the camshaft should be replaced. Further, if the base circle is less than **1.099 in. (27.93 mm)**, the camshaft should also be replaced. (Fig. 3-32)

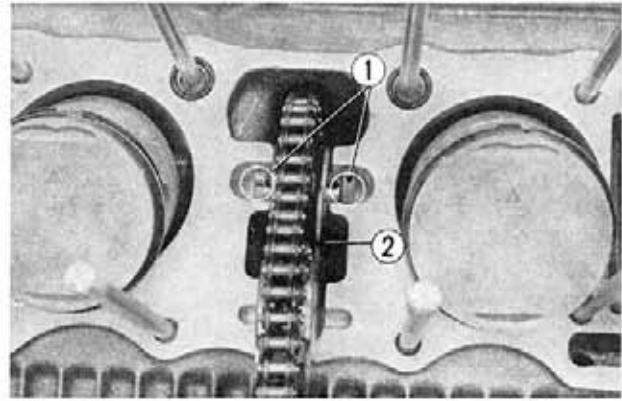


Fig. 3-28 ① Tensioner roller mounting rubbers
② Cam chain tensioner

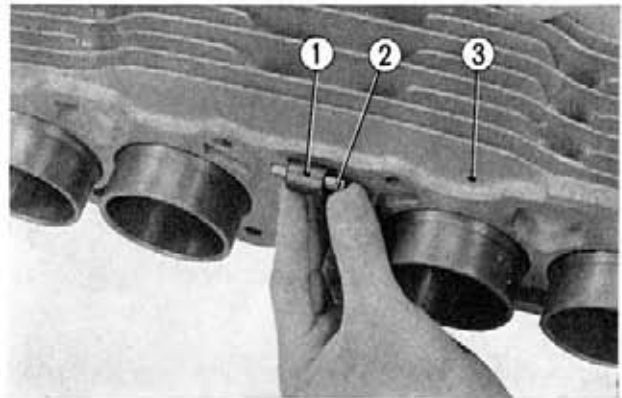


Fig. 3-29 ① Cam chain guide ③ Cylinder
② Cam chain guide pin

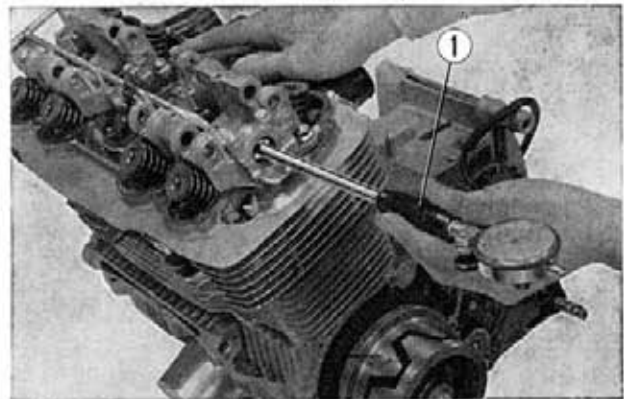


Fig. 3-30 ① Inside dial gauge

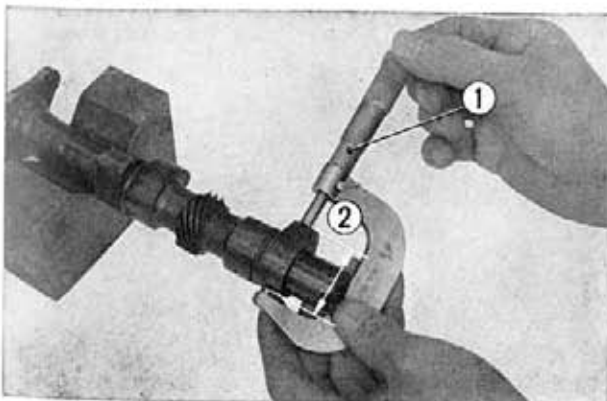


Fig. 3-32 ① Micrometer
② Cam height

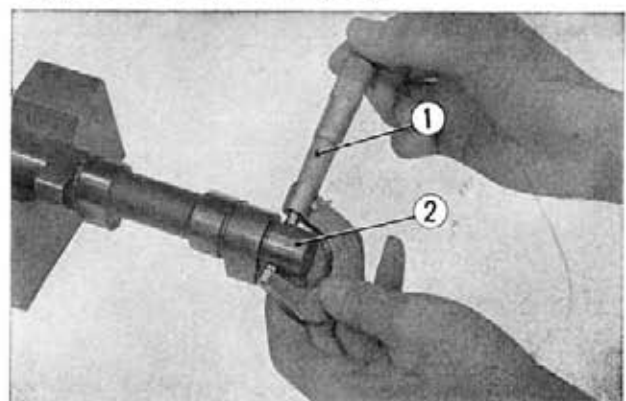


Fig. 3-31 ① Micrometer
② Camshaft bearing

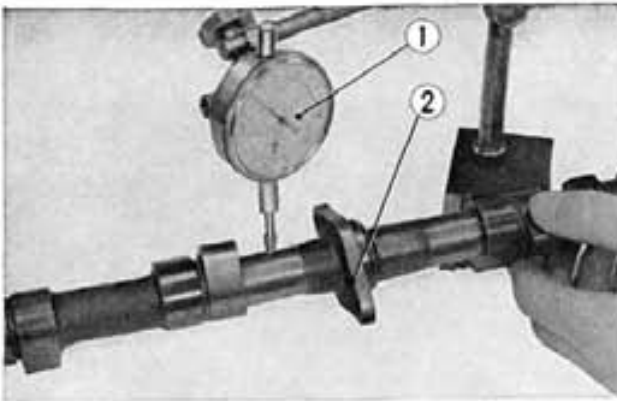


Fig. 3-33 ① Dial gauge
② Camshaft

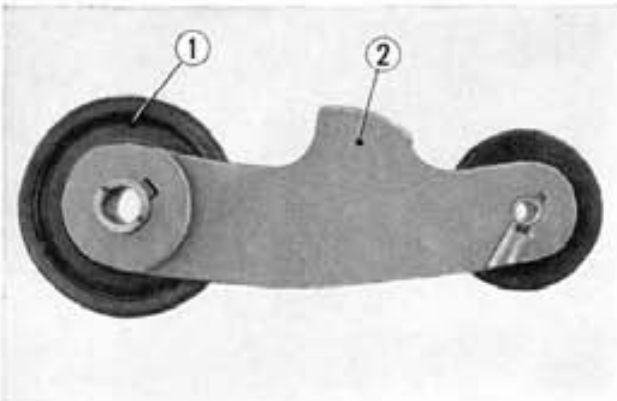


Fig. 3-34 ① Cam chain guide roller
② Cam chain tensioner

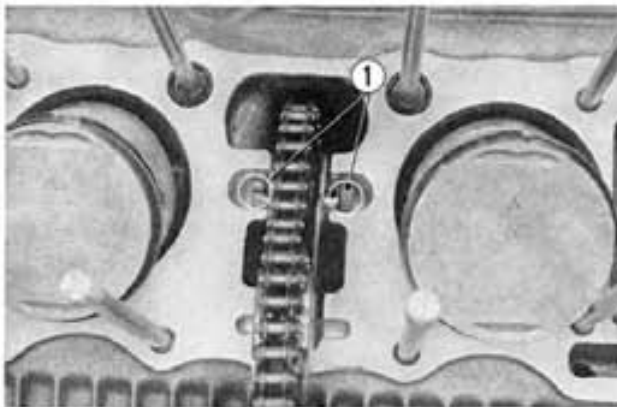


Fig. 3-35 ① Tensioner roller mounting rubbers

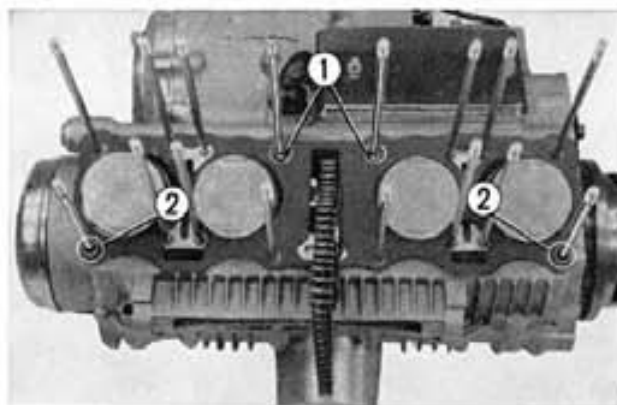


Fig. 3-36 ① "O" rings
② Dowel pins

3. Checking the bend in camshaft

Support both ends of the camshaft on the V blocks and check the dial gauge reading of the camshaft center support while rotating the camshaft. If the run-out is greater than 0.005 in. (0.1 mm) TIR, the camshaft should be replaced. (Fig. 3-33)

4. Inspect the camshaft and camshaft holder for scratches and cracks.

If found defective, it should be replaced.

5. Checking cam chain guide roller

Check the chain contact surface for wear, and replace it, if found to be excessive. (Fig. 3-34)

d. Reassembly

1. Route the cam chain through the cam chain tensioner roller, mount it on the upper crankcase and install the mounting rubbers. (Fig. 3-35)

2. Assemble the gasket, the two dowel pins (on both side of the exhaust), two O rings (on inner side of the inlet) and then install the cylinder being careful not to damage the piston or the piston rings. The work can be facilitated by using the piston ring compressor (Tool No. 07954-3000000) and the piston base (Tool No. 07958-3000000). (Fig. 3-36)

3. On the cylinder gasket flange, assemble the two dowel pins, two O rings and the cylinder gasket, and then mount the cylinder head followed by installing and torquing the mounting nuts and bolts in accordance with Fig. 3-38. Torqued the nuts to 13.7~15.2 ft-lbs. (1.9~2.1 kg-m.) (Fig. 3-37, 38)

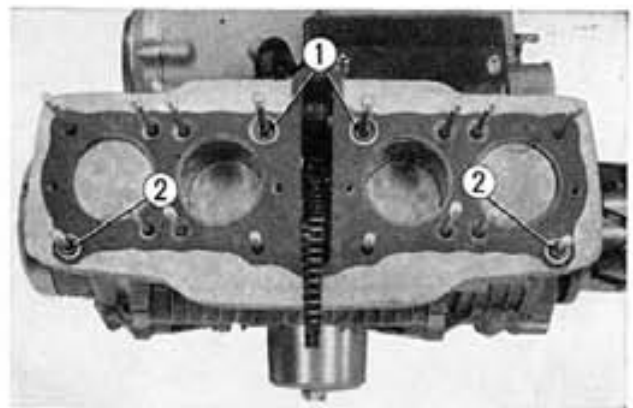


Fig. 3-37 ① "O" rings
② Dowel pins

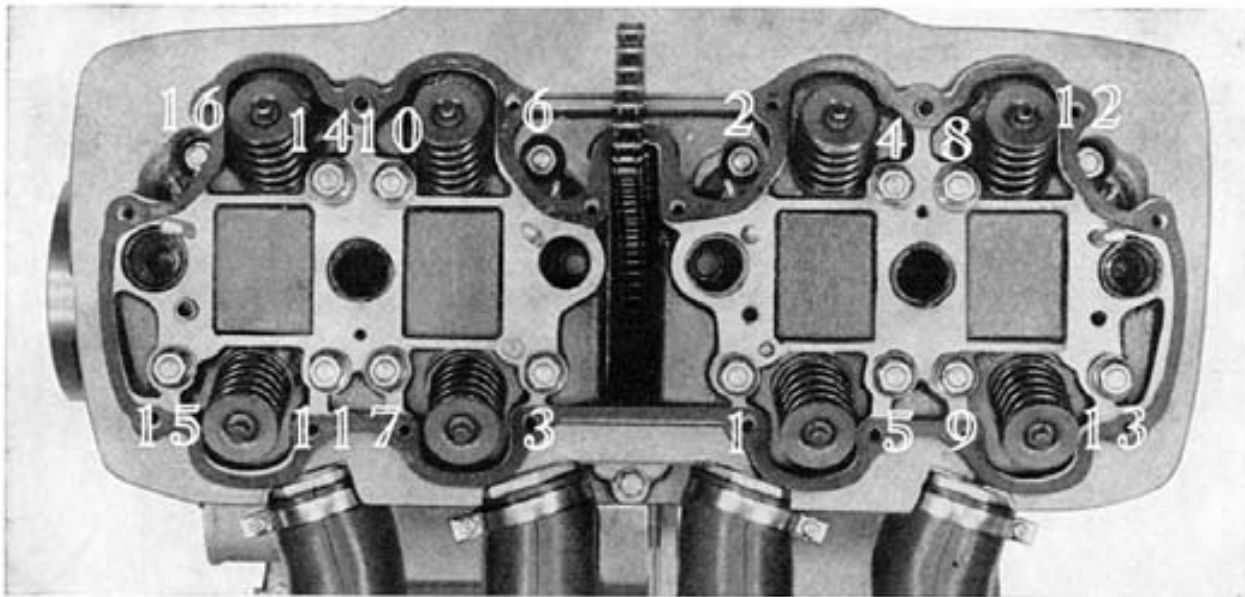


Fig. 3-38 Tightening sequence

CB 750 K4

● **Cylinder head gasket rings**

On the cars Engine No. 2352923 and after, a collar and oil seal (rubber) are inserted into between the cylinder and head at the points 4, 8, 5, 9, 14, 10, 11 and 7 in Fig. 3-38. **Note:** Install the oil seal onto the collar and insert them into the attaching hole in the cylinder.

4. Timing the valves

- a. Position the No. 1 and No. 4 cylinders to the top-dead-center by turning the crankshaft and aligning the No. 1 and No. 4 "T" marks on the spark advancer to the index mark (Fig. 3-39). During this operation, check the movement of the cam chain to make sure that it is properly fitted on the timing sprocket.
- b. Fit the cam sprocket on the camshaft and route the cam chain through the right side.
- c. Assemble the cam chain on the sprocket before mounting the cam sprocket. Place the camshaft on top of the camshaft holder and align the timing index line on the right side of the camshaft, so that it is parallel to the top surface of the camshaft holder. (The key groove must be toward the top). In this condition the base circle of the No. 4 cam is toward the top and the No. 1 cam is in the overlap position. (Fig. 3-40, 41)



Fig. 3-39 ① Index mark
② "T" mark

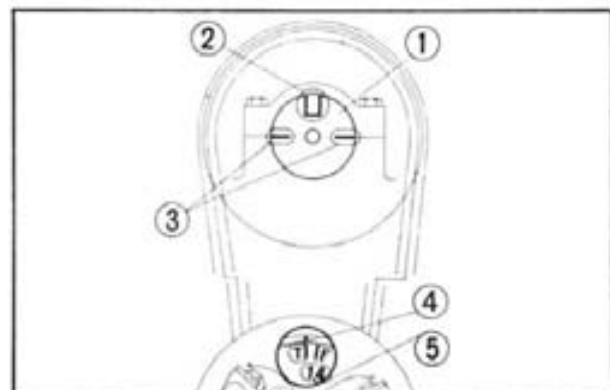


Fig. 3-40 ① Camshaft ④ "T" mark
② Groove ⑤ 1.4 mark
③ Index lines

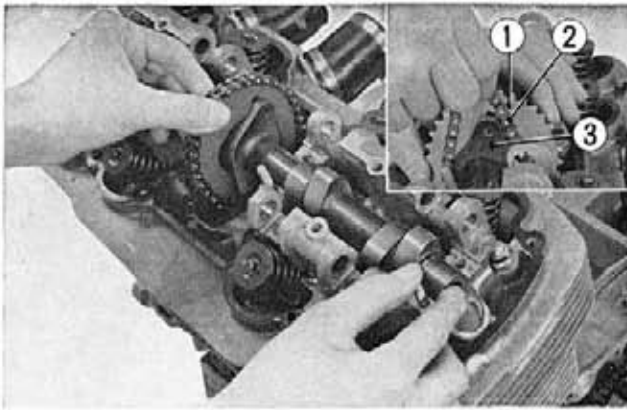


Fig. 3-41 ① Cam sprocket ② Cam chain ③ Cam shaft

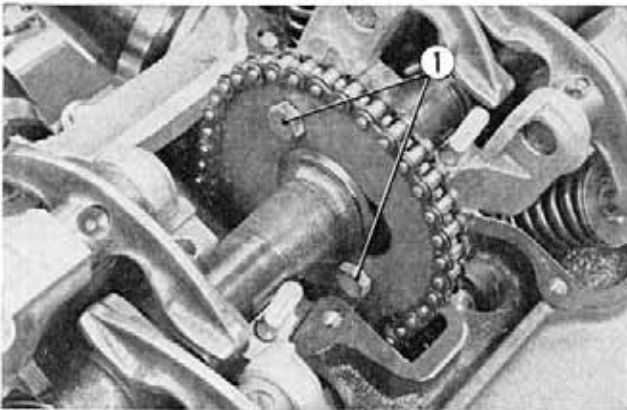


Fig. 3-42 ① Cam sprocket mounting bolts

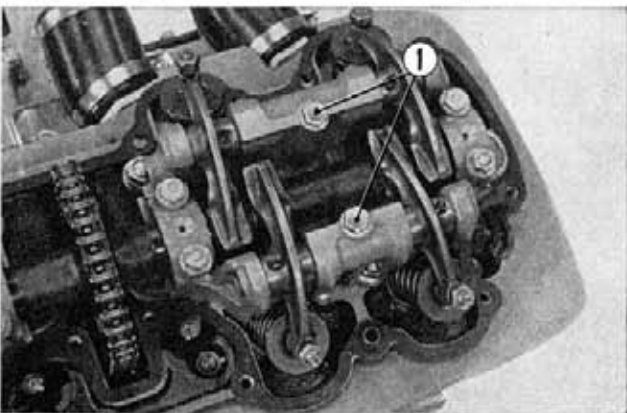


Fig. 3-43 ① Rocker arm shaft mounting bolts

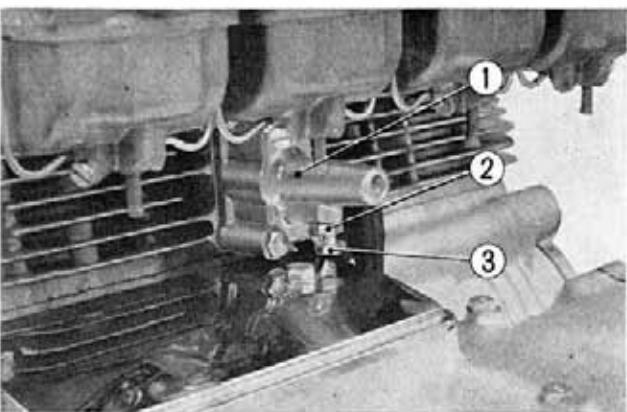


Fig. 3-44 ① Cam chain tensioner holder
② Lock nut
③ Tensioner adjusting bolt

d. At this point, the sprocket can be mounted on the camshaft with the two sprocket mounting bolts. (Fig. 3-42)

5. Mount the rocker arm on the rocker arm shaft and install the mounting bolts. (Fig. 3-43)

Note : Rocker arms No. 1 and No. 3, and No. 2 and No. 4 are interchangeable, therefore, do not error during installation.

6. Cam shaft holder and cap are matched set and can be identified by the identical numbers stamped on the holder and the cap. Torque the bolts to 6.5~9.4 ft-lbs (90~130 kg. cm)

7. Push in the push bar for the cam chain tensioner. Install the tensioner on the cylinder, loosen the tensioner adjusting bolts and then retighten the bolts and lock with the lock nut. (Fig. 3-44)

8. Adjust the valve tappet clearance. (Fig. 3-45) Refer to page 42~43.

9. Install the cylinder head cover with the sixteen cross screws.

10. Mount the breather cover with the three cross screws.

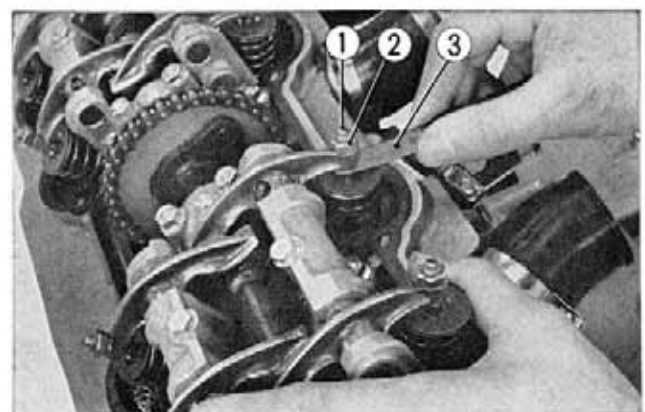


Fig. 3-45 ① Valve tappet adjusting screw
② Valve tappet lock nut
③ Thickness gauge

3-4 CYLINDER HEAD

Courtesy of Honda4Fun
www.honda4fun.com

The engine being on overhead camshaft type, the valves are located in the combustion chamber in the head. The combustion chamber is semi-spherical design for greater power output and the valve guides are press-fitted into the head.

Remove the valves.

Compress the valve springs using the valve spring compressor (Tool No. 07957-3290000) and remove the valve cotters, springs and valve in this order.

CAUTION: Compress the valve springs with care attention paid not to damage the valve stem seal.

b. Disassembly

1. Remove the cylinder head in accordance with section 3-3 b on page 26~29.

2. Disassemble the cylinder head using the valve remover (Tool No. 07031-30001 and 07031-30010) and disassemble the following parts: cotter, retainer, valve spring (both inlet and exhaust), valve stem seal, spring seat in the order. (Fig. 3-46)

3. Remove the valve guide using a valve guide removing tool (Tool No. 07942-3000000). (Fig. 3-47)

c. Inspection

1. Measuring the clearance between valve and valve guide

Insert the valve into the valve guide in the cylinder head and measure the clearance in both the X and Y axes, using a small dial gauge. (Fig. 3-48)

If the measured clearance is greater than **0.003 in. (0.08 mm)** for the inlet valve or **0.004 in. (0.1 mm)** for the exhaust valve, both the valve and valve guide should be replaced. The replacement valve guide should be one that is oversize. Use a valve guide driving tool (Tool No. 07942-3000000) to drive the valve guide fully into the head. (Fig. 3-49) Complete the valve guide installation by reaming out the valve guide using a valve guide reamer (Tool No. 07984-6110000) to the standard dimension. Standard inlet and exhaust valve guide inside diameter is **0.2599~0.2603 in. (6.6~6.61 mm)**.

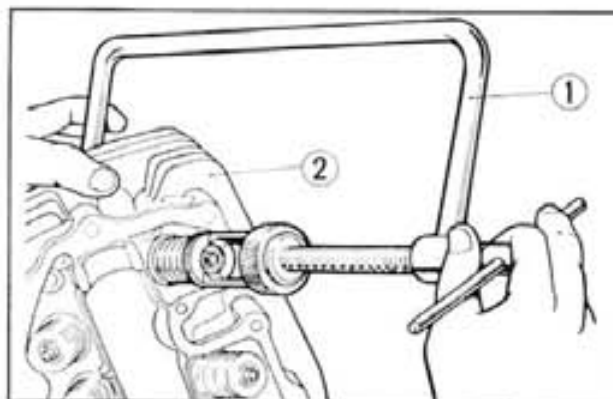


Fig. 3-46 ① Valve lifter
② Cylinder head

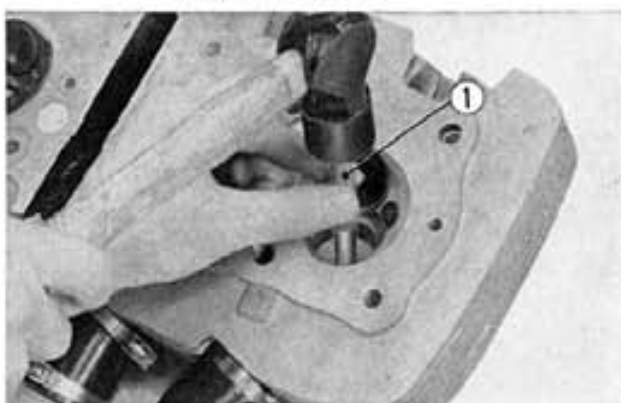


Fig. 3-47 ① Valve guide removing tool

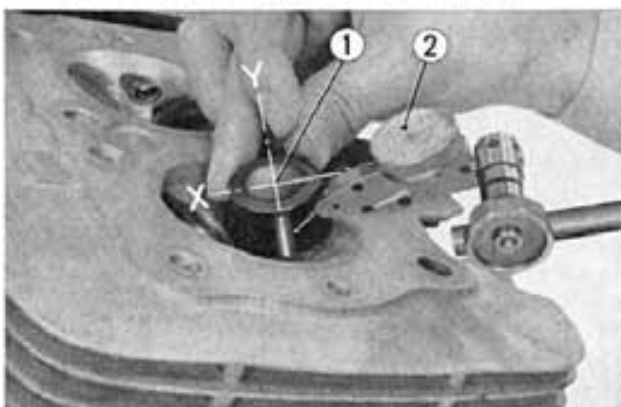


Fig. 3-48 ① Valve
② Dial gauge

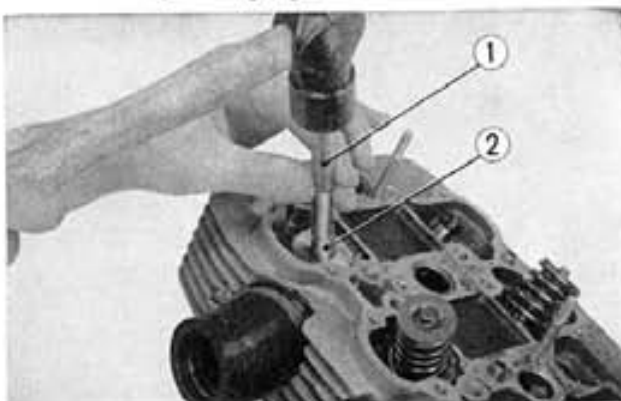


Fig. 3-49 ① Valve guide driving tool
② Valve guide

2. Measuring the width of the valve seat and vertical valve run-out

Place the valve on the V block and check the vertical run-out of the valve face by using a dial gauge. If the run out is greater than **0.002 in. (0.05 mm)**, the valve should be replaced. (Fig. 3-50) Further, measure the width of the valve face contact and if it is greater than **0.079 in. (2.0 mm)**, the valve should be replaced. However, if the valve is not seating uniformly, the valve seat should be repaired using a valve seat cutters.

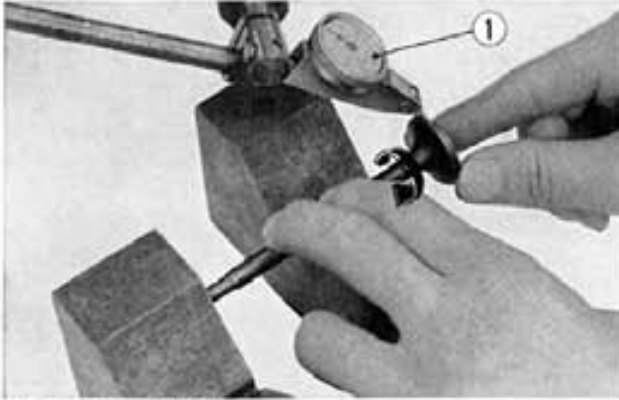


Fig. 3-50 ① Dial gauge

For information on the valve seat cutting operation, refer to Fig. 3-51.

There are three types of valve seat cutter shown in Fig. 3-51. The valve seat interior cutter will cut the bottom or the port side of the valve seat and the valve seat top cutter will cut the top of the valve seat (combustion chamber side). Finally, a 90° seat cutter is used to cut the seat. The width of the valve seat should be finished to **0.039 to 0.051 in. (1~1.3 mm)**. After the cutting of the valve seat, use a lapping

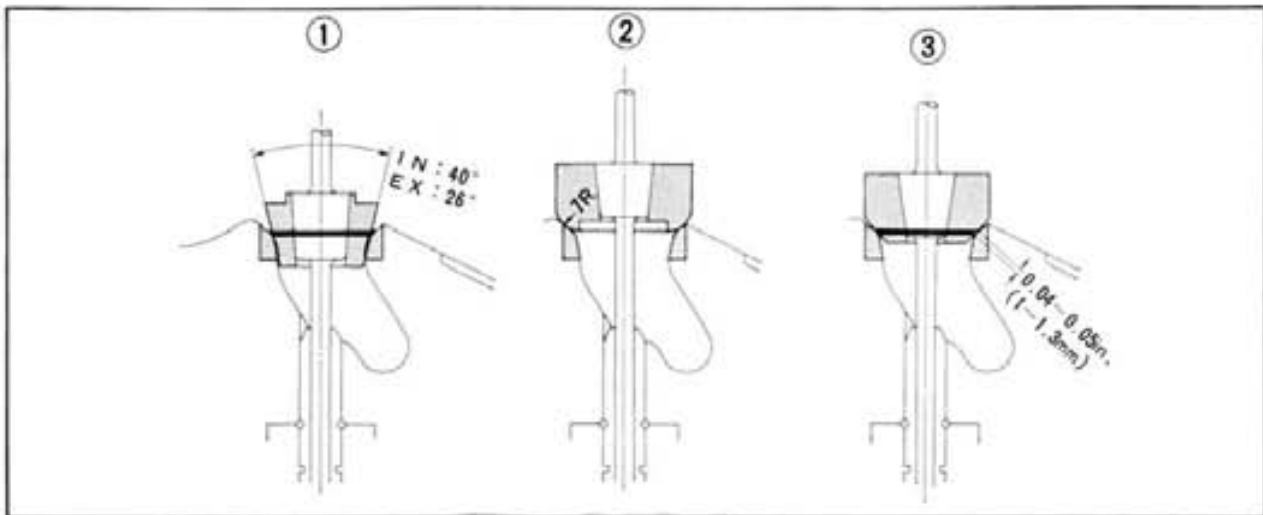


Fig. 3-51

① Valve seat interior cutter

② Valve seat top cutter

③ Valve seat 90° cutter

compounds to lap the valve to the new seat. Apply light coating of oil to the valve stem before assembling the valve into the cylinder head: Use the installation tool (Tool No. 07957-3290000)

CAUTION:

Use the valve seat grinder (tool No. 07782-0020000, A set) to correct the valve seat width and contact from the following serial number.

E No, CB 750 E-2242714~

Read carefully the instruction provided with the valve seat grinder.



3. Measuring the valve spring

Measure the free height of the valve spring using a vernier caliper and make sure that it conforms with this specification listed on the next page.

The spring forces are also listed the reference. (Fig. 3-52)

| Item | Standard value in. (mm) | Serviceable limit in. (mm) | Standard spring force |
|--------------------|-------------------------|----------------------------|-----------------------|
| Inner valve spring | 1.50 (38.1) | 1.4566 (37.0) | 22.8~25.8 kg/26 mm |
| Outer valve spring | 1.6220 (41.2) | 1.4748 (40.0) | 45.6~51.6 kg/28 mm |

4. Measure the rocker arm shaft support area with a micrometer and measure the rocker arm shaft bearing diameter bore using inside micrometer. Calculate clearance and if it is greater than **0.0047 in. (0.11 mm)**, replace either one or both of the parts. (Fig. 3-53)

5. Removing carbon from the combustion chamber.

Assemble the valve into the combustion chamber and remove the carbon using a carbon brush or a scraper, being careful not to scratch or damage the parts.

6. Measuring flatness of the cylinder head

Place a straight across the mounting surface of the cylinder head and check the clearance with a thickness gauge at several points to make sure that the head is not warped. If the clearance between straight edge and the head mounting surface is greater than **0.009 in. (0.25mm)**, the head should be reworked or replaced by a new head. In any event, the warp of the head should be less than **0.002 in. (0.05 mm)**.

(Fig. 3-54)

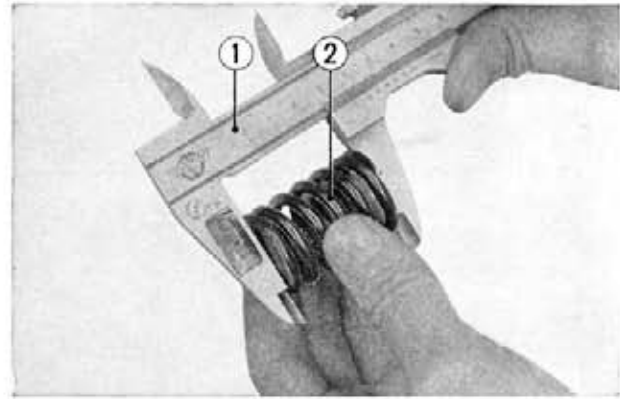


Fig. 3-52 ① Vernier caliper
② Spring

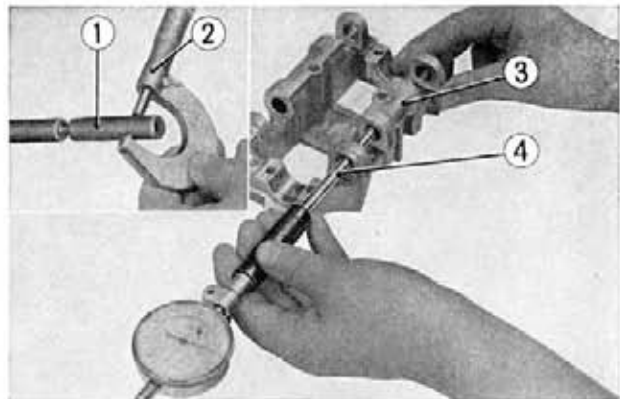


Fig. 3-53 ① Rocker arm shaft
② Micrometer
③ Camshaft holder
④ Inner dial gauge

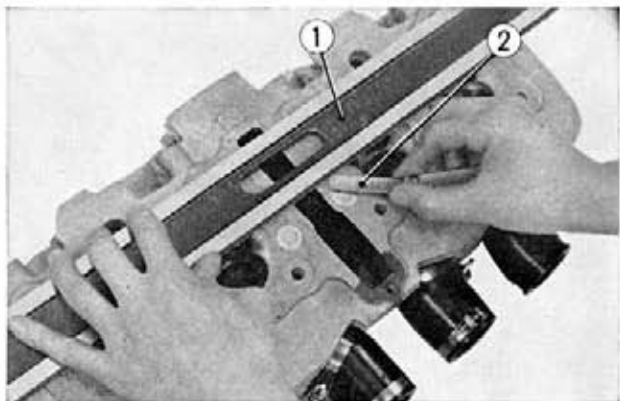
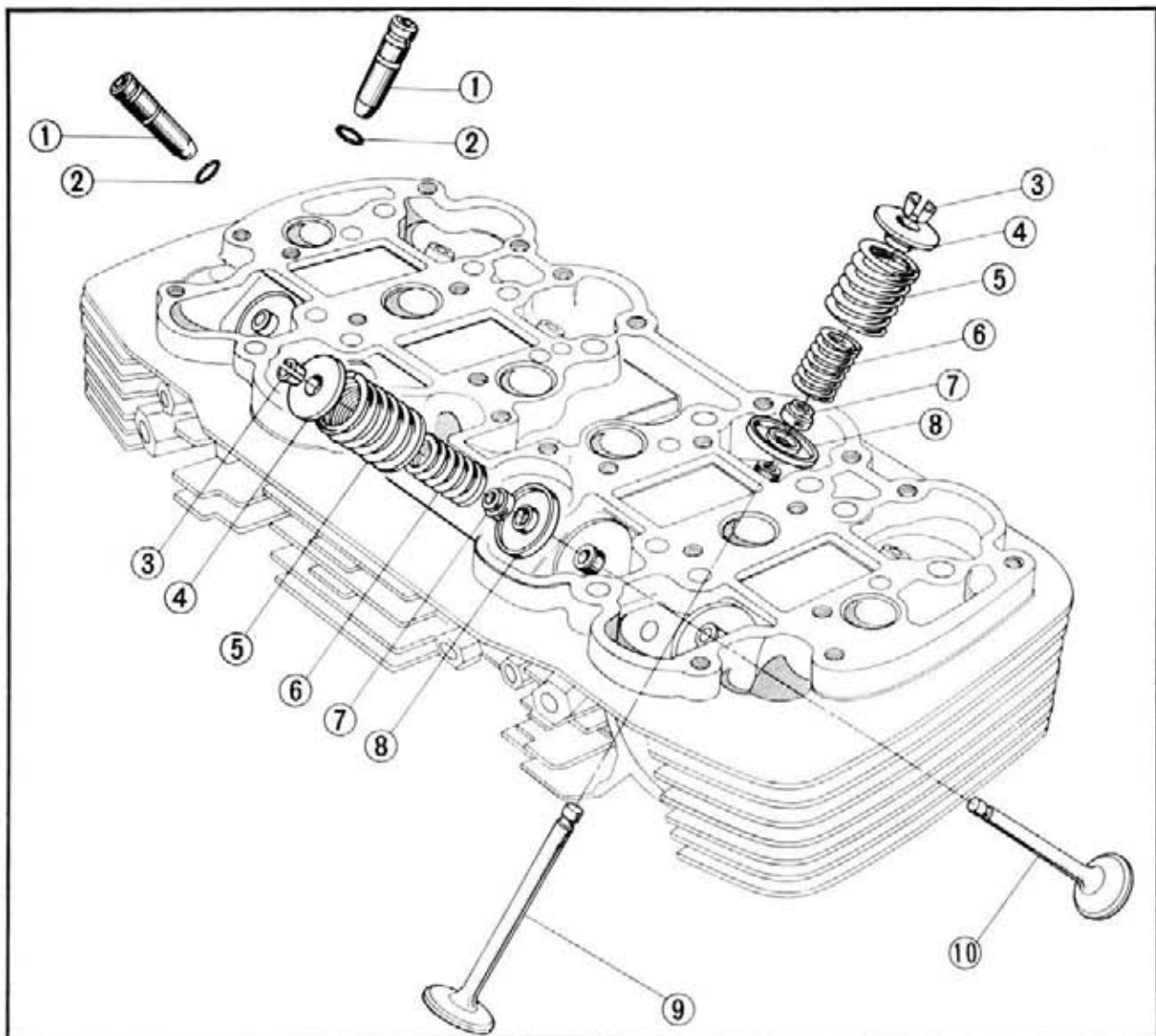


Fig. 3-54 ① Stretch
② Thickness gauge

d. Reassembly

1. Clean the component parts of the cylinder head and assemble them in accordance with Fig. 3-55.



- | | |
|----------------------|----------------------|
| ① Valve guide | ⑥ Inner valve spring |
| ② Set ring | ⑦ Valve stem seal |
| ③ Valve cotter | ⑧ Valve spring seat |
| ④ Valve retainer | ⑨ Exhaust valve |
| ⑤ Outer valve spring | ⑩ Inlet valve |

Fig. 3-55

2. Install the cylinder head in accordance with section 3-3 d on page 36~38.
3. After assembling cylinder head, the valve tappet clearance should be performed to assure proper clearance in the following manner.
 - a. While slowly rotating the crankshaft clockwise (see arrow) watch the #1 cylinder inlet valve tappet. When this tappet retracts all the way and then starts to rise, watch for the alignment of the timing index mark and the "T" mark. Check the 1-4 cylinder mark. In this position the #1 piston will be at T.D.C. (top dead center) of the compression stroke, and both the inlet and exhaust valves in that cylinder should be fully closed. The valve tappet clearances of the valves marked with the O in the table on the next page can be checked. (Fig. 3-56)

| | No. 1 | No. 2 | No. 3 | No. 4 |
|----|-------|-------|-------|-------|
| IN | ○ | × | ○ | × |
| EX | ○ | ○ | × | × |

Note : The cylinder are numbered 1~4 starting from the left side.

b. Check the clearance of both valves by inserting the thickness gauge, provided in the tool kit, between the tappet adjusting screw and the valve stem. If clearance is correct, there will be slight drag or resistance as the gauge is inserted. If clearance is too small or large, adjustment is necessary. (Fig. 3-57)

The standard valve tappet clearance is

IN 0.002 in (0.05 mm)
EX 0.003 in (0.08 mm)

c. Adjustment is made by loosening the tappet screw lock nut and turning the adjusting screw until there is a slight drag on the thickness gauge. Hold the tappet adjusting screw in this position and tighten the lock nut. Recheck the clearance with the gauge. Next, turn the crankshaft 360°, this will put No. 4 piston into the top-dead-center of the compression stroke and will permit the checking of the remaining valve tappet clearances marked × in the table above.

4. Install the cylinder head cover and breather cover.

3-5 PISTON AND CYLINDER

a. Description

The piston is made from selected aluminum alloy casting. This material is light and making it suitable for high speed. In addition, it possess good heat conducting property to rapidly dissipate heat. Furthermore, the coefficient of heat expansion is small thus minimizing the warpage at elevated temperature and permitting a small piston to cylinder clearance design.

b. Disassembly

1. Remove the cylinder in accordance with section 3-3 b on page 32~35.
2. Remove the piston pin clip, push out the piston pin and remove the piston from the connecting rod. (Fig. 3-58)

Note : During the piston pin clip removal, exercise care not to drop the clip into the crankcase.

3. Remove the piston rings from the piston.



Fig. 3-56 ① Index mark
② "T" mark

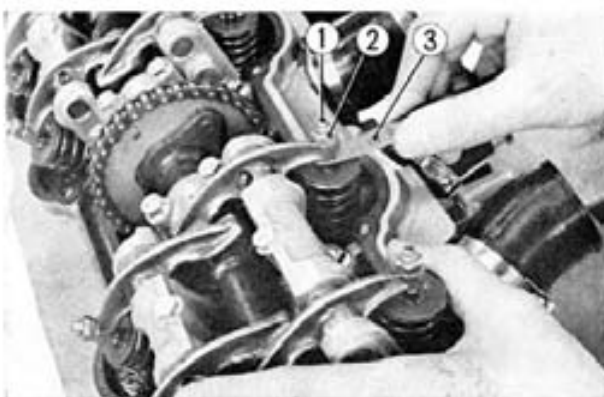


Fig. 3-57 ① Valve tappet adjusting screw
② Valve tappet lock nut
③ Thickness gauge

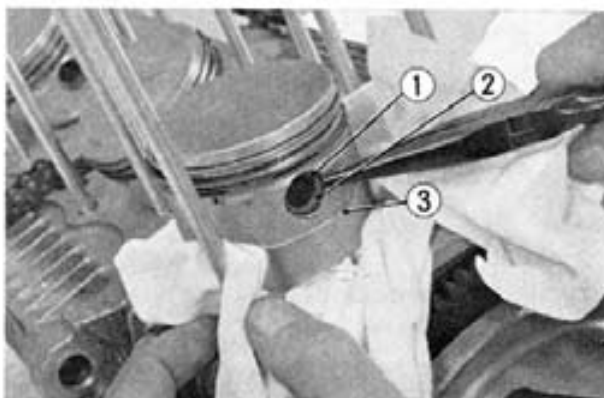


Fig. 3-58 ① Piston pin clip ③ Piston
② Piston pin

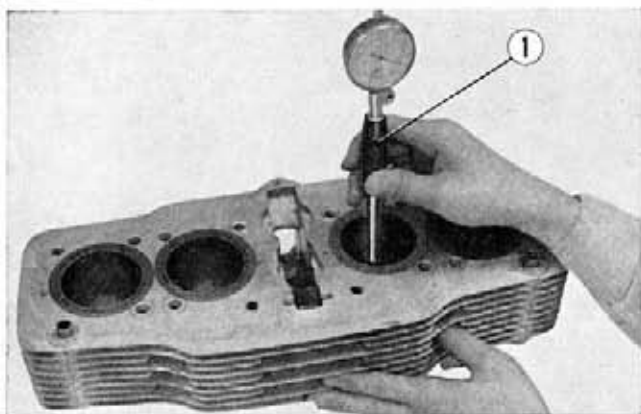


Fig. 3-59 ① Cylinder gauge

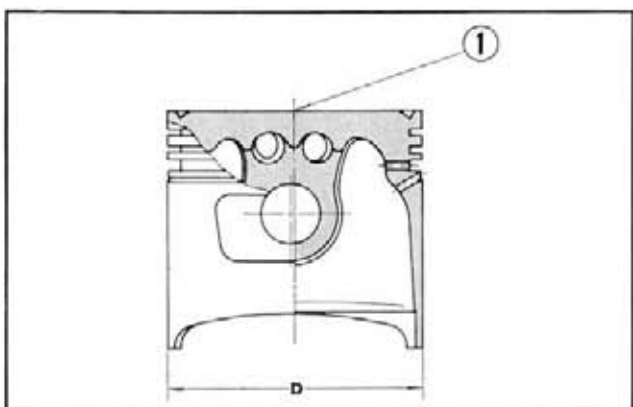
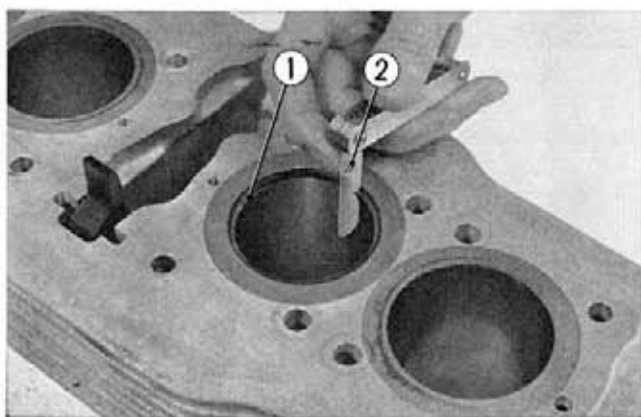


Fig. 3-60 ① Piston

Fig. 3-61 ① Micrometer
② PistonFig. 3-62 ① Piston ring
② Thickness gauge

c. Inspection

1. Measuring the cylinder bore, taper and out of round. (Fig. 3-59)

Measure the cylinder bore at the top, center and bottom, measuring in both X and Y axes, using a cylinder gauge.

If the diameter is greater than **2.406 in. (61.1 mm)**, the cylinder should be rebored and honed. Further, if the taper and the out of round is greater than **0.0020 in. (0.05 mm)**, the cylinder should be repaired in same manner as above.

Measure the cylinder diameter at the point of maximum wear. Next, select the proper oversize piston to be used (0.25 mm to 1 mm oversize in increments of 0.25 mm) and determined the proper boring dimension. When boring is completed, finish up by honing. The minimum clearance between the piston and the cylinder is at the skirt section with a dimension of **0.0004~0.0016 in. (0.01~0.04 mm)**.

- Oversize piston diameter (Fig. 3-60)

| Oversize | | Piston diameter (D) |
|----------|------|---------------------|
| O/S | 0.25 | 61.215~61.235 mm |
| O/S | 0.50 | 61.465~61.485 mm |
| O/S | 0.75 | 61.715~61.735 mm |
| O/S | 1.00 | 61.965~61.985 mm |

2. Measuring the diameter of the piston
Measure the piston diameter at the skirt, 90° from the pistonpin hole, using a micrometer. If the dimension is less than **2.3939 in. (60.85 mm)**, it should be replaced. (Fig. 3-61)
3. Removing the carbon

Remove the carbon from the piston top and the ring groove by using a carbon scraper.

If the ring groove is damaged or excessively worn, the piston should be replaced.

4. Measuring the piston ring end gap (Fig. 3-62)

Fit the ring into the cylinder bore and measure the gap at the end of the ring using a thickness gauge. When only the ring is to be replaced without boring the cylinder wear, the ring gap should be measured at the skirt of the bore.

| Rings | Serviceable limit |
|---------------------|---------------------|
| Top and second ring | 0.0276 in. (0.7 mm) |
| Oil ring | 0.0276 in. (0.7 mm) |

5. Measuring the ring side clearance
Measure the clearance between the piston ring and the ring lands using a thickness gauge. (Fig. 3-63)

If clearance is beyond the specified value shown below, they should be replaced.

| Rings | Serviceable limit |
|-------------|-----------------------|
| Top ring | 0.0071 in. (0.18 mm) |
| Second ring | 0.0065 in. (0.165 mm) |
| Oil ring | 0.0045 in. (0.114 mm) |

6. Measuring the piston pin bore (Fig. 3-63)
Measure the piston pin bore using an inside micrometer or inner dial gauge and if the dimension is over 0.5938 in. (15.08 mm), the piston should be replaced. (Fig. 3-64)

d. Reassembly

- When assembling the new rings on the piston, roll the rings around the piston ring groove to check for proper clearance before assembling. (Fig. 5-65)
- The piston ring should be installed with manufacturer marking located at the end of the ring toward the top. (Fig. 5-66)
- Assemble the piston on the connecting rod so that the arrow mark on top of the piston is toward the exhaust side (forward) then install all new piston pin clips. (Fig. 3-67)
- Spaced piston ring gaps of all three rings to 120° apart and then install the piston into the cylinder and then assemble the cylinder.
- For other information, refer to page 36~38.

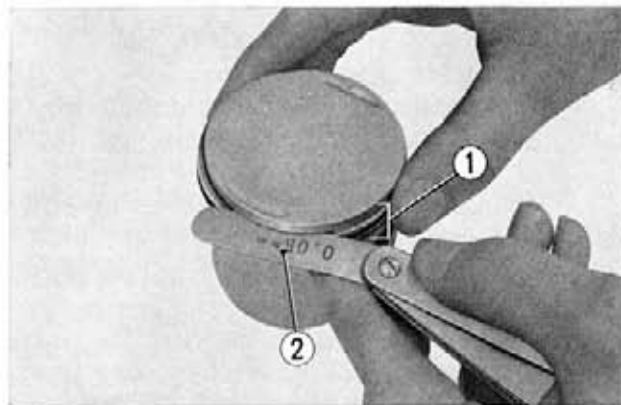


Fig. 3-63 ① Piston ring ② Thickness gauge

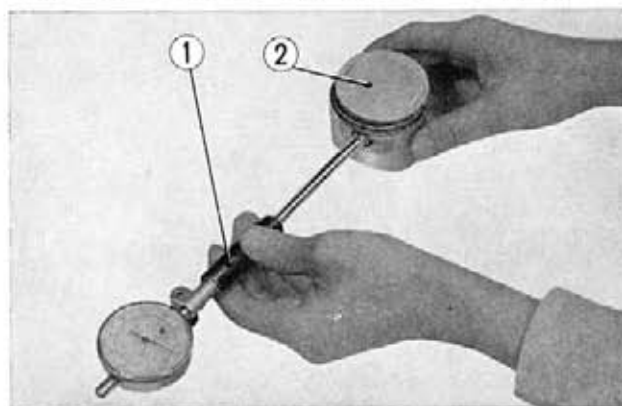


Fig. 3-64 ① Inner dial gauge
② Piston

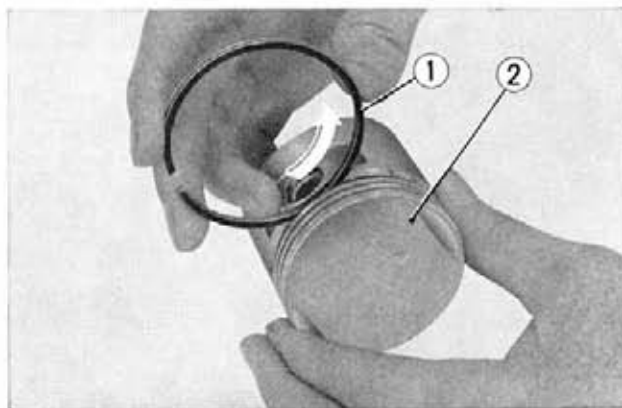


Fig. 3-65 ① Piston ring
② Piston

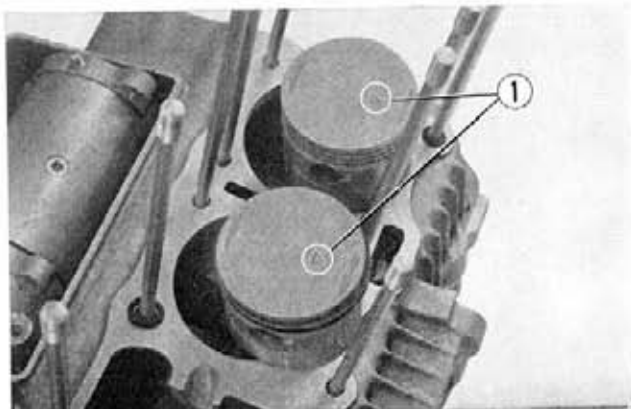


Fig. 3-67 ① Arrow marks

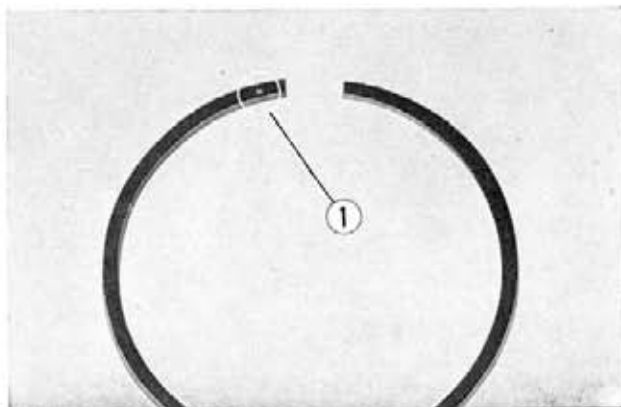


Fig. 3-66 ① Manufacturer mark

3-6 CRANKSHAFT AND CONNECTING ROD

a. Description

The forged single unit crankshaft is supported on five main plain bearings.

The large end of the connecting rod is split type with plain bearings and the small end has no busing.

The main bearing and connecting rod large end bearings are made of tin alloy.

b. Disassembly

1. Remove the cylinder head, cylinder and cam chain tensioner in accordance with 3-3 b, page 32~35.

2. Remove the dynamo cover.

3. Unscrew the AC generator mounting bolt and remove the AC generator rotor using the rotor puller (Tool No. 07933-3000000). (Fig. 3-68)

4. Remove the starting motor reduction gear and the starting clutch gear. (Fig. 3-69)

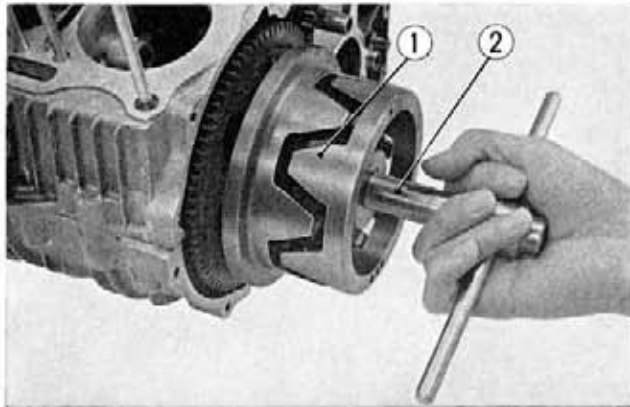


Fig. 3-68 ① A.C. generator rotor
② Rotor puller

5. Remove the gear shift arm, gear shift side plate, gear shift drum stopper and the gear shift positive stopper. (Fig. 3-70)

6. Remove the point cover and unscrew the 6 mm hex nut and remove the advancer shaft special washer. (Fig. 3-71)

7. Unscrew the three contact breaker assembly mounting screws and remove the contact breaker (Fig. 3-71).

8. Remove the spark advancer.

9. Remove the spark advancer shaft.

10. Remove the clutch in accordance with section 4-2 a on page 59.

11. Remove the counter shaft bearing holder. (Fig. 3-72)

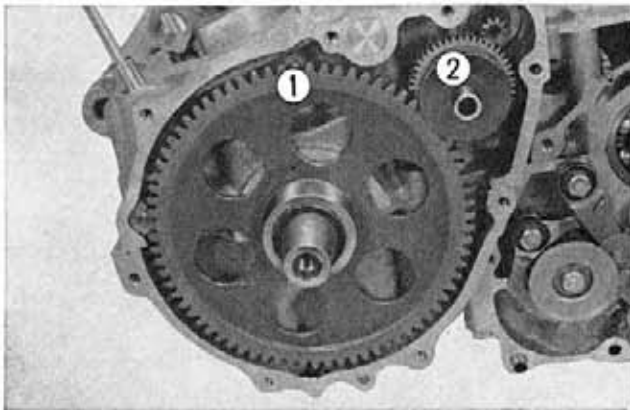


Fig. 3-69 ① Starting clutch gear
② Starting motor reduction gear

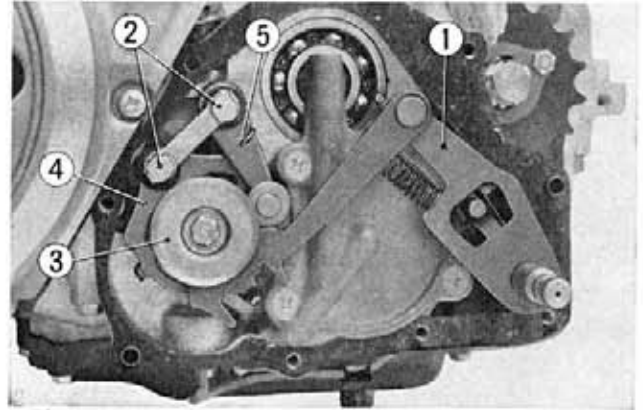


Fig. 3-70 ① Gear shift arm
② 6mm bolts
③ Gear shift side plate
④ Gear shift positive stopper
⑤ Shift drum stopper

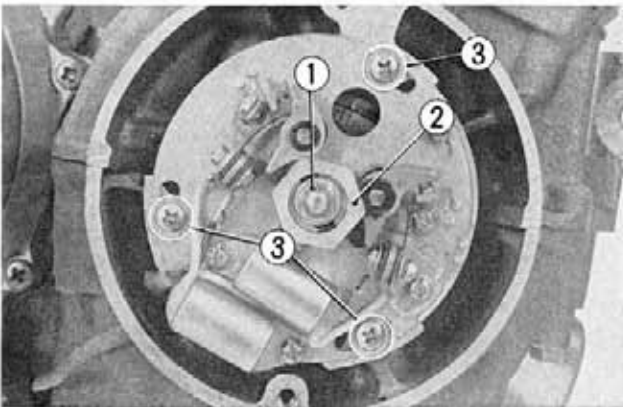


Fig. 3-71 ① 6mm hex. nut
② Advancer shaft special washer
③ Breaker assembly mounting screws

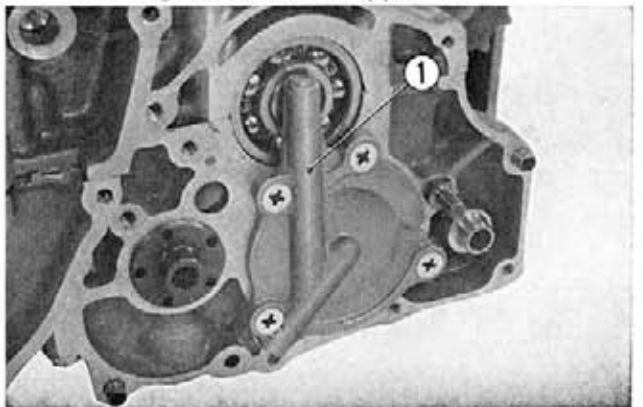


Fig. 3-72 ① Counter shaft bearing holder

12. Loosen the upper crankcase mounting bolts. (Fig. 3-73)
13. Unscrew the lower crankcase mounting bolts and separate the lower crankcase from the upper crankcase. (Fig. 3-74)
14. Raise the transmission mainshaft and remove the primary sprocket and then remove the primary chain from the primary sprocket. (Fig. 3-75)
15. Remove the crankshaft from the upper crankcase. (Fig. 3-76)
16. Unscrew the connecting rod cap mounting bolts and remove the bearing cap from the large end, and then remove the connecting rod from the crankshaft. (Fig. 3-77)

c. Inspection

1. Measuring the bend of the crankshaft.

Support both ends of the crankshaft on V blocks and check the run-out at the center journal by rotating the crankshaft and taking a reading with a dial gauge. The amount of run-out is 1/2 of the true indicated reading (TIR) on the dial gauge. If the run-out is greater than 0.002 in. (0.05 mm), the crankshaft should be straighten with a press. (Fig. 3-78)

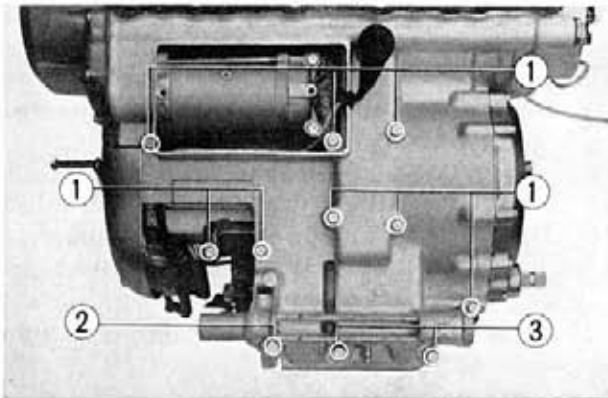


Fig. 3-73 ① 6mm bolts ② 10mm bolt ③ 8mm bolts

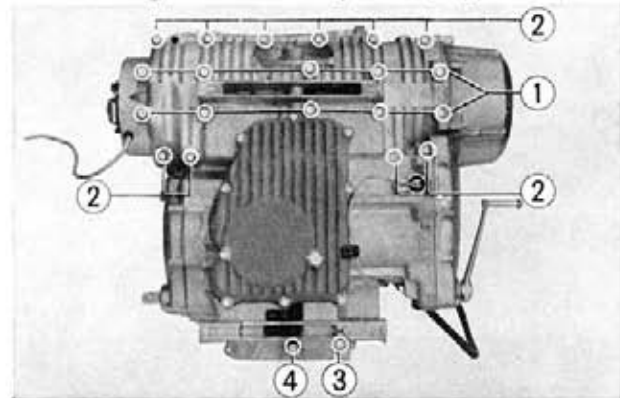


Fig. 3-74 ① 8mm bolts ② 6mm bolts ③ 10mm nut ④ 8mm nut

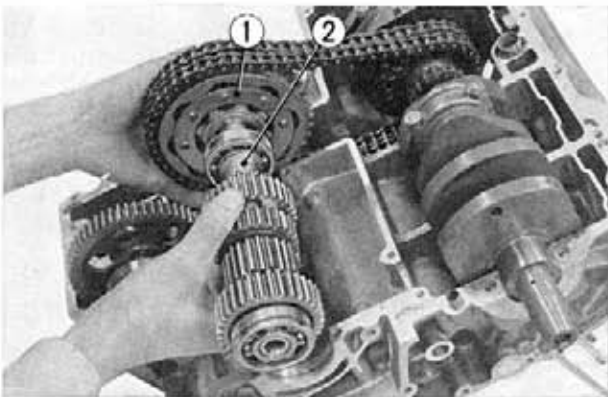


Fig. 3-75 ① Primary sprocket ② Transmission mainshaft

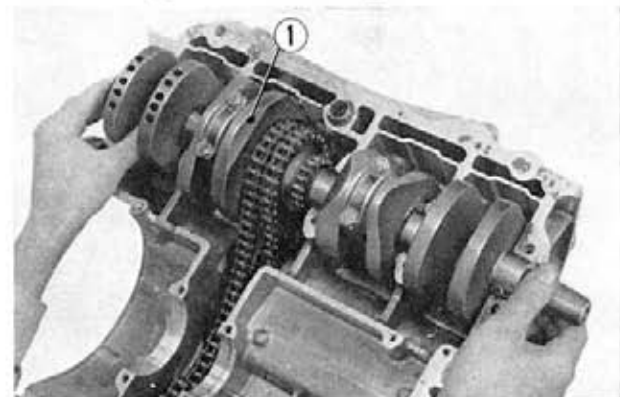


Fig. 3-76 ① Crankshaft

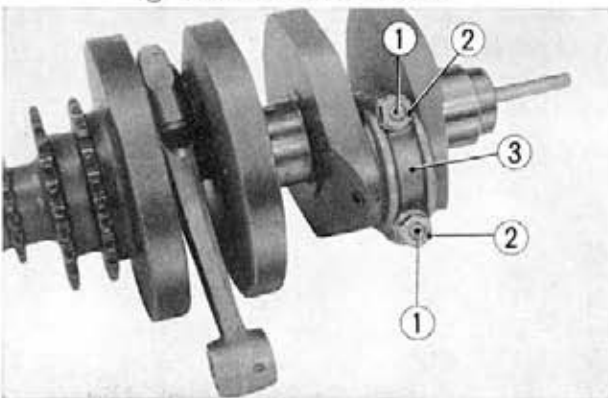


Fig. 3-77 ① Connecting rod bolts ② Connecting rod nuts ③ Connecting rod

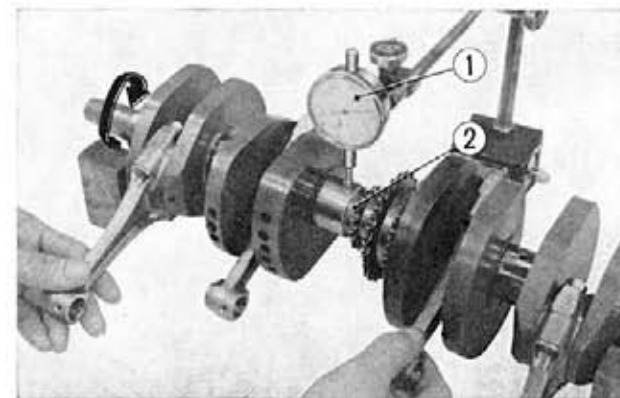


Fig. 3-78 ① Dial gauge ② Crankshaft

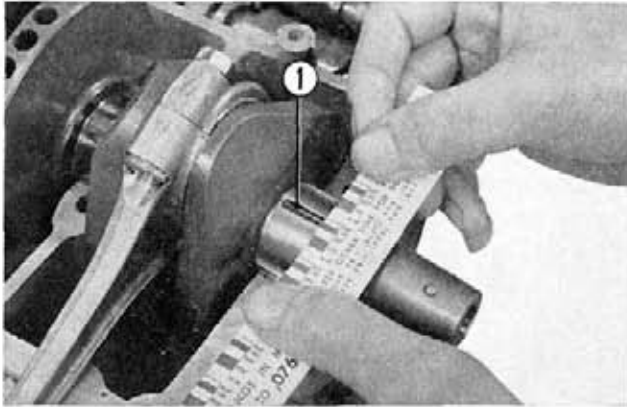


Fig. 3-79 ① Press gauge

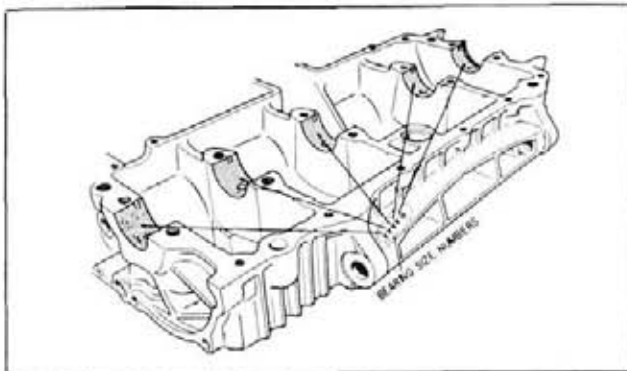


Fig. 3-80

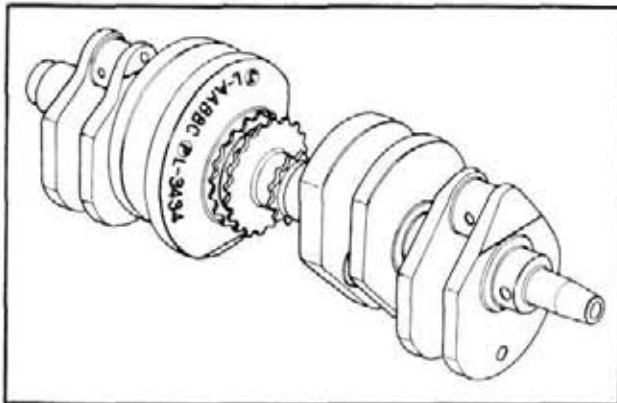


Fig. 3-81

2. Measuring the wear of the crankshaft journals

- a. Remove the crankshaft and clean the crankshaft journal.
- b. Cut the press gauge material to the length of bearing parallel to the crankshaft. Stay clear of the oil hole.
- c. Assemble the crankshaft, lower crankcase and torque down the mounting bolts. Next, disassemble the lower crankcase, and check the gauge which had been flattened by comparing it with the scale on the package of the press gauge. (Fig. 3-79)

Measure the gauge at the widest point; also note the different in width at both ends. If the bearing clearance is larger than **0.0032 in. (0.08 mm)**, the bearing should be replaced with new part.

The standard bearing clearance should be 0.0008~0.0018 in. (0.02~0.046 mm).

Note: 1. Do not turn the crankshaft while making this measurement.

2. The bearing must be replaced in set.

- d. The bearings are select fitted by the following procedures.

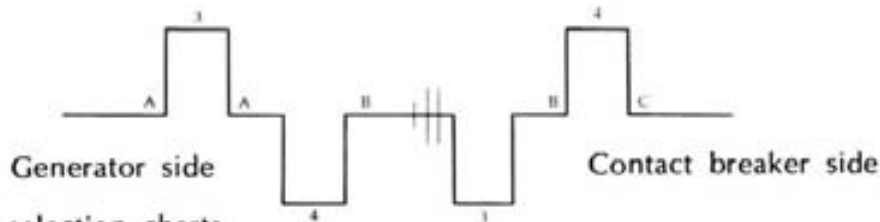
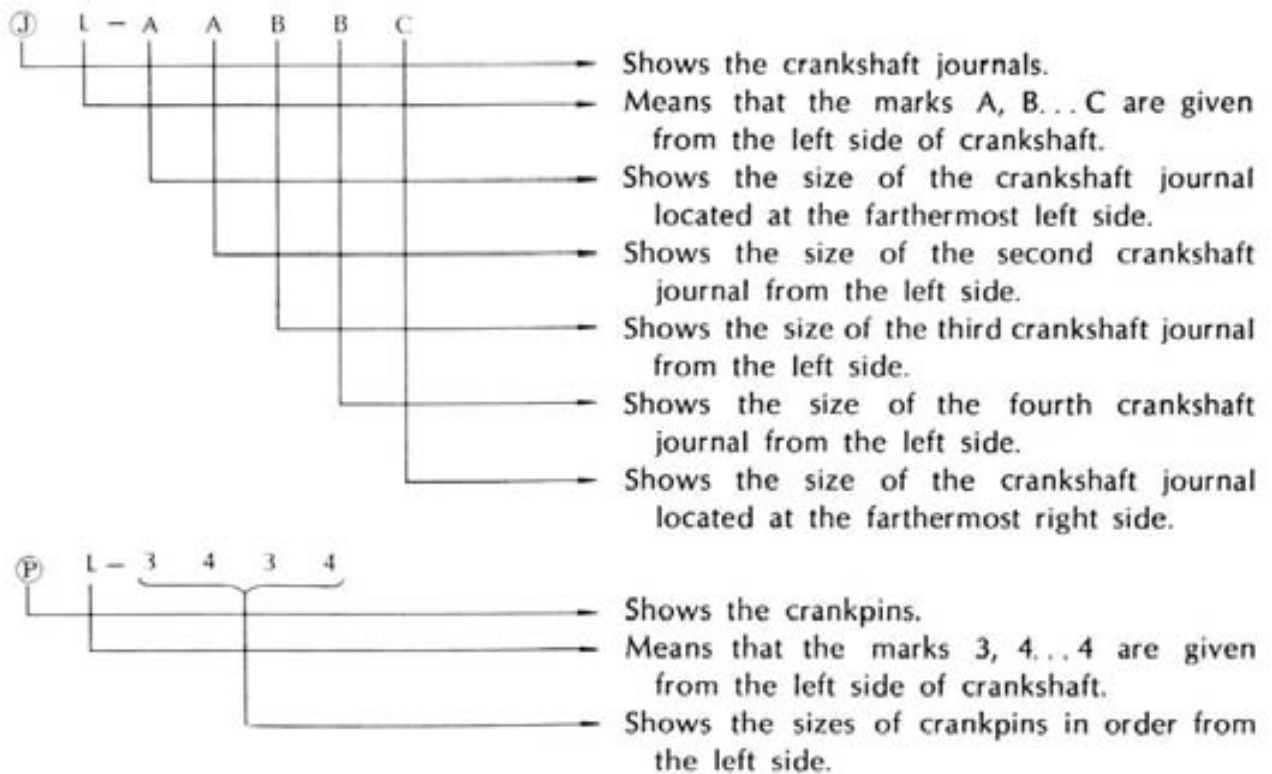
- There are alphabet letters stamped on the forward section of the upper crankcase hanger bolt inserts. The stamped letter indicates the bearing size. Bearings are numbered sequence, starting from the right side. (Fig. 3-80)

• Crankshaft Bearing

The type of bearings as explained here is applicable from the engine No. CB750 E1015587 and thereafter.

The size marks of crankshaft journals were changed from 1 (I) □ (RO) 八 (HA) and = (NI) to A, B and C. These marks are stamped on the side of the crank weight on the drive sprocket side together with the crankpin size marks. (Fig. 3-81)

Description of stamped marks



Bearing metal selection charts

The bearing metals of crankshaft journals and crank pins are respectively available in four selective sizes. They are selective-fitted so that a proper oil clearance can be obtained. When replacing a bearing, selecte the bearing metal of the correct size according to the bearing metal selection charts below. As a rule, use the bearing metal having the same mark put on the metal used hitherto

Crankshaft Journal Bearing Metal Selection Table

| Marking | Crankcase | | | Crankshaft | | | Bearing | | | |
|-------------------|-------------|-------------|-------------|-------------|-------------|-------------|------------------------|-------------|-------------|-------------|
| | A | B | C | A | B | C | Black | Brown | Green | Yellow |
| Dimension (mm) | 39.000 | 39.008 | 39.016 | 36.000 | 35.995 | 35.990 | 1.5002 | 1.4998 | 1.4994 | 1.4990 |
| | { 39.008 | { 39.016 | { 39.024 | { 35.995 | { 35.990 | { 35.985 | { 1.4998 | { 1.4994 | { 1.4990 | { 1.4986 |
| Oil clearance (μ) | | | | | | | | | | |
| 20-41 | A | | | A | | | Yellow (13318-300-013) | | | |
| 22-43 | A | | | C | | | Green (13317-300-013) | | | |
| 25-46 | A | | | B | | | Yellow (13318-300-013) | | | |
| 20-41 | B | | | A | | | Green (13317-300-013) | | | |
| 22-43 | B | | | B | | | Green (13317-300-013) | | | |
| 25-46 | B | | | C | | | Brown (13316-300-013) | | | |
| 20-41 | C | | | A | | | Brown (13316-300-013) | | | |
| 22-43 | C | | | B | | | Brown (13316-300-013) | | | |
| 25-46 | C | | | C | | | Black (13315-300-013) | | | |

- e. Check the respective journal for damage or uneven wear. If the journal is out-of-round or tapered in excess of **0.002 in. (0.05 mm)**, the crankshaft should be replaced with new part.
- f. When a new crankshaft is used as a replacement, select the proper size bearings referring to the selection table.
- g. When the bearing is mounted into the crankcase, the top of the bearing should be extended above the case mounting flange by **0.0027~0.0039 in. (0.068~0.098 mm)**.

Caution :

The shell of the bearing is very thin, therefore, care should be exercised that it is not damaged during installation. Bearing which is deeply scored, having a poor fit or when there is a large foreign object imbedded in the bearing, it should be replaced with a new bearing. Further, repairs of the listed below should not be attempted.

- a. Adjusting with a shim
 - b. Repairing with a scraper
 - c. Use of red or bluing to check the bearing contact.
 - d. Correcting the clearance by filing the connecting rod or the connecting rod cap.
 - e. Applying emery paper on the bearing surface in an attempt to correct the bearing.
4. Measuring the connecting rod bearing
(Method using micrometer and inside dial gauge)
- a. Accurately measure the crank pin diameter with the micrometer.
Take the measurement in both vertical and horizontal direction at the front, center and rear.
 - b. Assemble the bearing into the connecting rod and torque the cap to the specified value, **14.5 ft-lbs (2 kg-m)**, and measure the bearing inside diameter parallel to the rod at the front, center and rear locations.

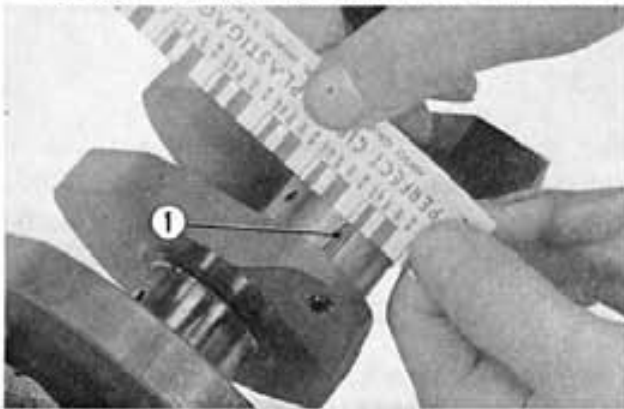


Fig. 3-82 ① Press gauge

(Press gauge method)

- a. Remove the connecting rod cap and clean all oil from the bearing and pin.
- b. Cut the press gauge to width of the bearing and place it on top and parallel to the pin, staying clear of the oil hole.
- c. Assemble the connecting rod on the crankshaft and torque the rod cap to the specified torque, **14.5 ft-lbs (2 kg-m)**.
- d. Disassemble the connecting rod bearing and measure the flattened gauge by comparing it to the scale on the package of the gauge. (Fig. 3-82)

The clearance is taken as the average value between the lowest and the highest readings. The standard bearing clearance is **0.0008~0.0018 in. (0.02~0.046 mm)**.



Fig. 3-83-1

If the clearance is beyond **0.0032 in. (0.08 mm)**, the bearing should be replaced with new part.

- Numbers (3, 4, 5) are stamped on the side surface of the crank weight, this indicates the crank pin size. (Fig. 3-81)
- The numerical figures stamped on the connecting rod indicates the size of the connecting rod large end. Select the proper size bearing by referring to the table on the next page. The bearings are color coded on the end surface.



Crank Pin Bearing Metal Selection Table

| Marking | Connecting Rod | | | Crank Pin | | | Bearing | | | |
|-------------------------|-----------------------|-----------------------|-----------------------|-----------------------|-----------------------|-----------------------|------------------------|-----------------------|-----------------------|-----------------------|
| | 1 | 2 | 3 | 1 | 2 | 3 | Black | Brown | Green | Yellow |
| Dimension (mm) | 39.000 } 39.008 | 39.008 } 39.016 | 39.016 } 39.024 | 36.000 } 35.995 | 35.995 } 35.990 | 35.990 } 35.985 | 1.5002 } 1.4998 | 1.4998 } 1.4994 | 1.4994 } 1.4990 | 1.4990 } 1.4986 |
| Oil clearance (μ) | | | | | | | | | | |
| 20-43 | 1 | | | 3 | | | Yellow (13218-300-013) | | | |
| 22-43 | 1 | | | 5 | | | Green (13217-300-013) | | | |
| 25-46 | 1 | | | 4 | | | Yellow (13218-300-013) | | | |
| 20-41 | 2 | | | 3 | | | Green (13217-300-013) | | | |
| 22-43 | 2 | | | 4 | | | Green (13217-300-013) | | | |
| 25-46 | 2 | | | 5 | | | Brown (13216-300-013) | | | |
| 20-41 | 3 | | | 3 | | | Brown (13216-300-013) | | | |
| 22-43 | 3 | | | 4 | | | Brown (13216-300-013) | | | |
| 25-46 | 3 | | | 5 | | | Black (13215-300-013) | | | |

Connecting rods (Weight identification)

The connecting rods are carefully selected in weight to minimize the vibration of engine. The rods of the same weight should be used as a set. This marking method is applied to the engine No. E 1026594 and thereafter.

When replacing a connecting rod, select the connecting rod according to the following table, if any, on the old rod and then select the connecting rod bearing metal having the same fit mark on the old metal. The weight identification mark is as shown in Fig. 3-83-2.

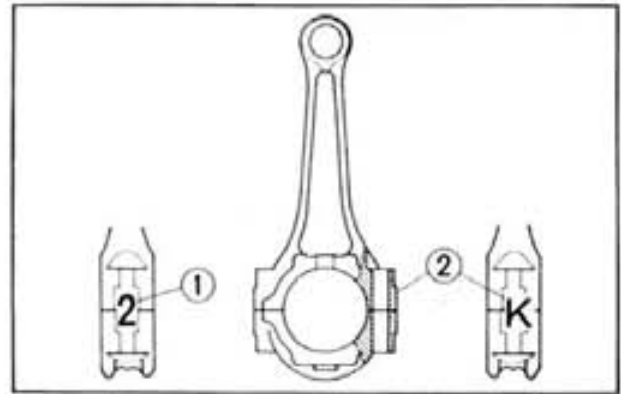


Fig. 3-83-2 ① Tolerance identification mark (Metal fit mark)
② Weight identification mark

Weight identification marks

| Mark | Used parts | |
|------------------|------------|---------------|
| | Mark | Parts No. |
| A B C D | D | 13204-300-000 |
| E F | F | 13206-300-000 |
| G H J K | H | 12208-300-000 |

d. Reassembly

1. Assemble the cam chain and primary chain on the crankshaft and assemble it into the upper crankcase.
2. Assemble the primary chain on the primary sprocket and install the sprocket on the main shaft. (Fig. 3-84)
3. Install the two dowel pins, oil pass collar and an "O" ring on the upper crankcase and apply a uniform coating of liquid packing on the mating flange. (Fig. 3-85) Carefully set the lower crankcase on top, and install the mounting bolts and torque in the pattern shown in Fig. 3-86 to a value of 16.6~18.1 ft-lbs (2.3~2.5 kg-m) for 8 mm hex. bolts and next, tighten the 6 mm hex. bolts.

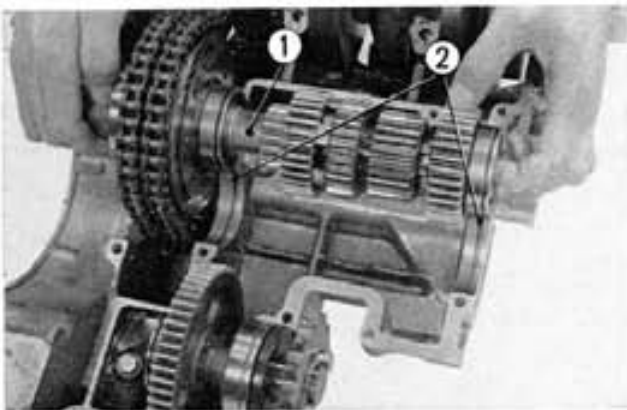


Fig. 3-84 ① Transmission mainshaft
② Bearing set rings

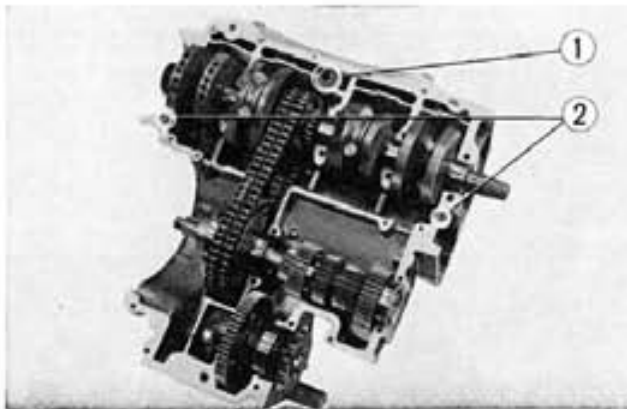


Fig. 3-85 ① Oil pass collar & "O" ring
② Dowel pins

4. Turn the crankcase assembly and torque down the upper crankcase.
5. Install the countershaft bearing and then assemble the gear change positive stopper, drum stopper and the gear shift arm (Fig. 3-70).
6. Install the clutch (refer to page 60~61).

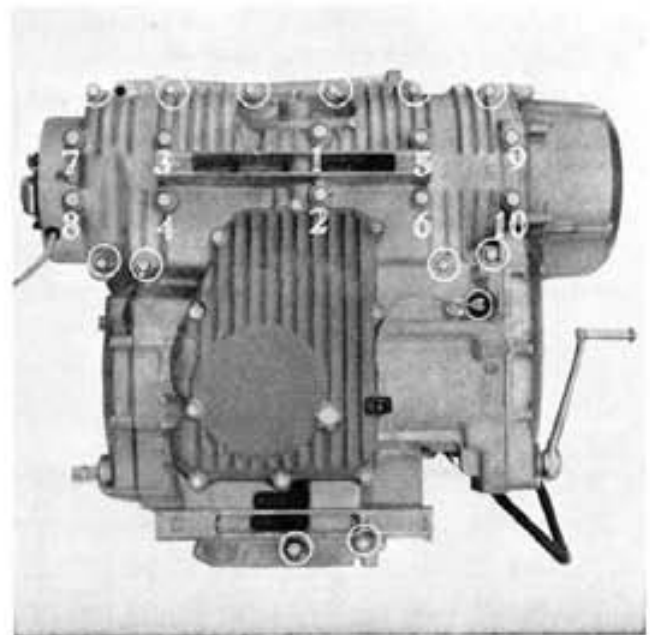


Fig. 3-86 Tightening sequence

7. Mount the spark advancer shaft and install the spark advancer.

Note: Pin on the back side of the advancer must fit into the crankshaft pin hole. (Fig. 3-87)

8. Mount the contact breaker assembly plate, special washer and tighten the 6 mm nuts.
9. Install the starting motor reduction gear, and the starting clutch gear.
10. Install the AC generator with the mounting bolt and torque to 72.3ft-lbs (10kg-m).
11. Install the cylinder and cylinder head in accordance with page 36-38.

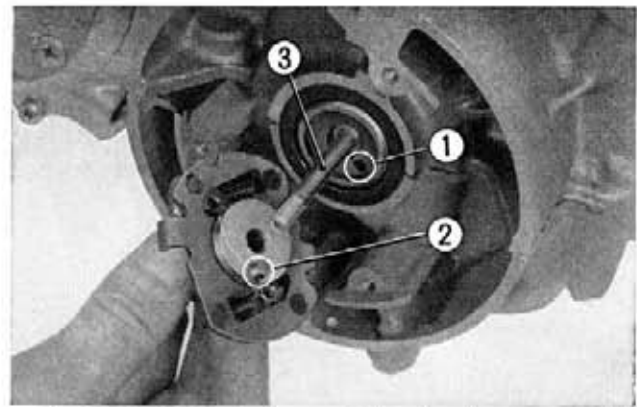


Fig. 3-87 ① Pin hole ③ Spark advancer shaft
② Spark advancer pin

3-7 PRIMARY DRIVE

a. Description

The power is transmitted from the crankshaft to the primary driven sprocket through the two single row chains and further transmitted to the transmission through the clutch.

The crankshaft speed is reduced to the ratio of 1.708 between crankshaft sprocket and primary driven sprocket.

The primary tensioner is incorporated to reduce chain vibration.

b. Disassembly

1. Remove the cylinder head, cylinder in accordance with section 3-3 b on page 32~35.
2. Remove the piston in accordance with section 3-5 b on page 43.
3. Remove the crankcase in accordance with section 3-6 b on page 46~47.
4. Raise the transmission mainshaft and remove the primary driven sprocket from the mainshaft and then remove the primary chain from the primary driven sprocket. (Fig. 3-88)
5. Raise the crankshaft and remove the primary drive chain from the crankshaft.
6. Remove the primary chain tensioner from the lower crankcase. (Fig. 3-89)

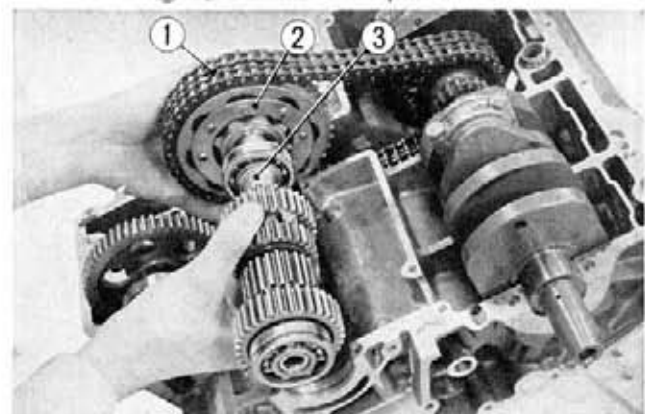


Fig. 3-88 ① Primary chain
② Primary sprocket
③ Transmission mainshaft

c. Inspection

1. Checking the primary drive chain

The check of the primary drive chain stretch can be made without disassembling the engine.

- a. Remove the drain plug and drain the oil from the crankcase.

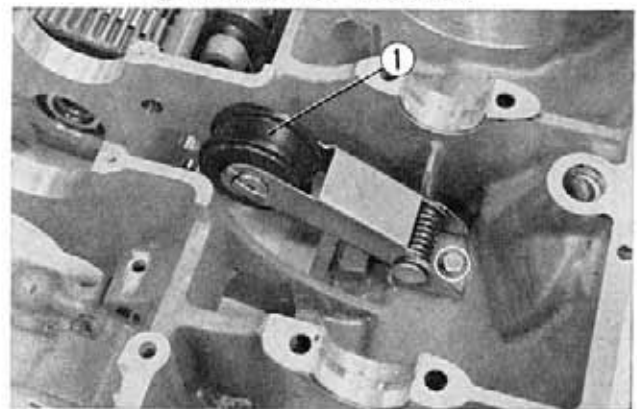


Fig. 3-89 ① Primary chain tensioner

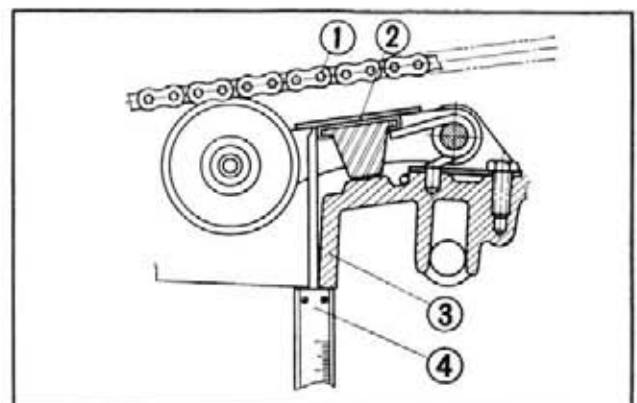


Fig. 3-90 ① Primary chain ③ Lower crankcase
② Primary sprocket ④ Vernier caliper

- b. Remove the ten oil pan mounting bolts and drop the oil pan.
- c. Measure the distance between the primary chain tensioner bracket and the oil pan mounting flange (Fig. 3-90) with the vernier caliper.

If the dimension is over 2.756 in. (70 mm), the chain should be replaced.

2. Check the rubber roller on the tension for wear, damage or deterioration and replace if defective.

d. Reassembly

1. Assemble the primary drive chain in the reverse procedure of disassembly.
2. Assemble the crankcase in accordance with section 3-6 d on page 51-52.
3. Assemble the piston in accordance with section 3-5 d on page 45.
4. Assemble the cylinder, cylinder head in accordance with section 3-3 d on page 36-38.

3-8 KICK STARTER

a. Description

When the kick starter pedal is operated by kicking the starter spindle, turns in the direction of the arrow as shown in the Fig. 3-91.

The kick starter flange which is mounted on the starter spindle contains the kick starter pawl which is hooked in the groove of the kick starter gear. Operating the kick starter transmits the rotary force from the spindle through the starter gear and clutch to turn the crankshaft. When the engine starts, the rotary force produced by the crankshaft is transmitted from the crankshaft to the clutch outer, and to the kick starter gear where the kick starter pawl becomes disengaged. (Fig. 3-91)

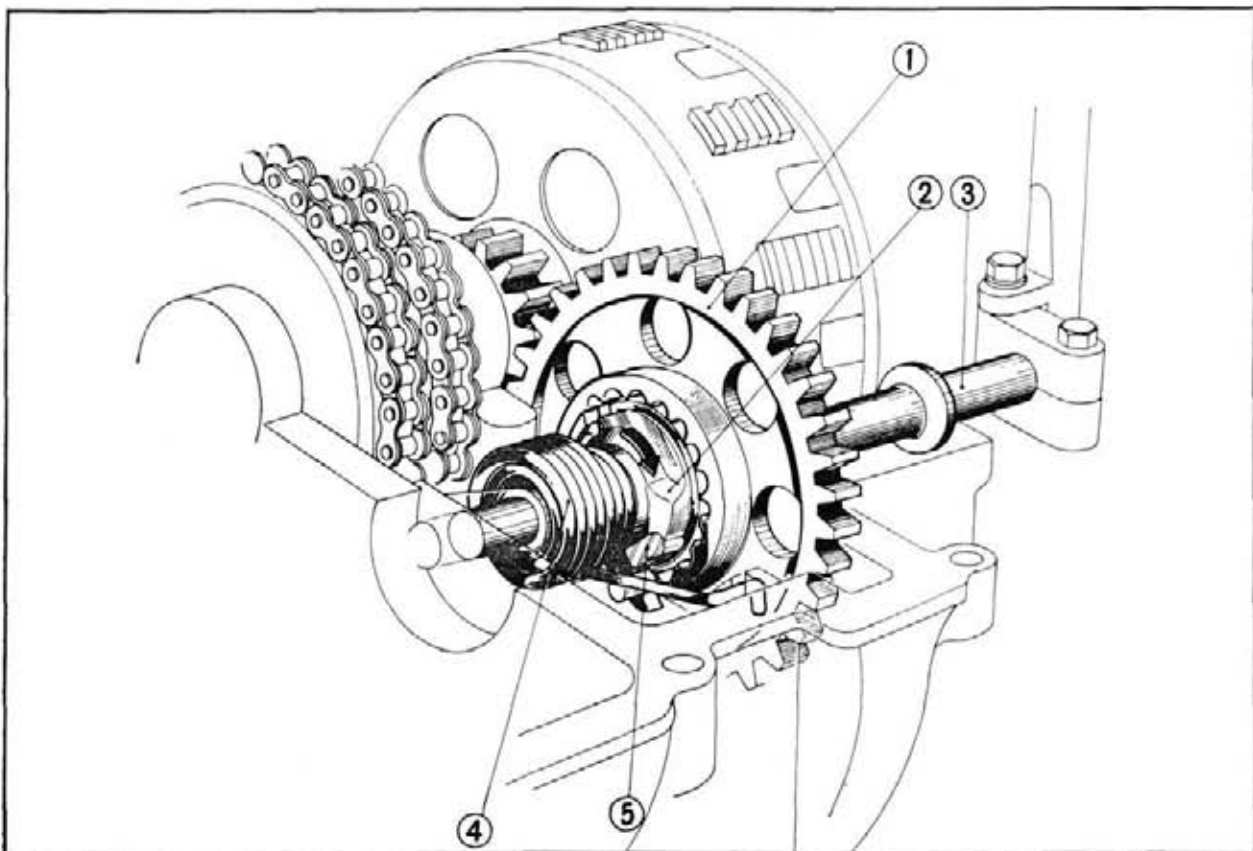


Fig. 3-91

① Kick starter gear
② Kick starter flange

③ Kick starter spindle
④ Kick starter return spring

⑤ Kick starter pawl

b. Disassembly

1. Disassemble the cylinder head, and cam chain tensioner in accordance with section 3-3 b on page 32~35.
2. Disassemble the crankcase in accordance with section 3-6 b on page 46-47.
3. Remove the kick starter shaft stopper pin and remove the kick starter shaft. (Fig. 3-92)
4. Remove the kick starter gear assembly. (Fig. 3-93)
5. Remove the kick starter return spring.
6. Remove the kick starter ratchet spring from the kick starter flange and then remove the kick starter pawl.

c. Inspection

1. Check to make sure that the kick gear turns smoothly in one direction and locks in the opposite direction.
2. Check the bore of the kick gear with an inside dial gauge and the starter shaft with a micrometer and if the dimension is beyond the serviceable limit shown in the table below, the parts should be replaced. (Fig. 3-94)

| Item | Serviceable limit in. (mm) |
|------------------------|-------------------------------|
| Kick gear bore | 0.7904 (20.075) |
| Starter shaft diameter | 0.7847 (19.930) |

d. Reassembly

1. Assemble the kick gear, kick starter flange and return spring together into the lower crankcase. (Fig. 3-95)

Note : Hook the end of the return spring on the case, force the starter flange toward the bottom with a screwdriver to hook it on the pin.

2. Install the kick starter spindle (Fig. 3-96).
3. Install the kick spindle stopper pin (Fig. 3-96)
4. Assemble the crankcase in accordance with section 3-6 d on page 51~52.
5. Assemble the cylinder, cylinder head and cam chain tensioner in accordance with section 3-3 d on page 36-38.

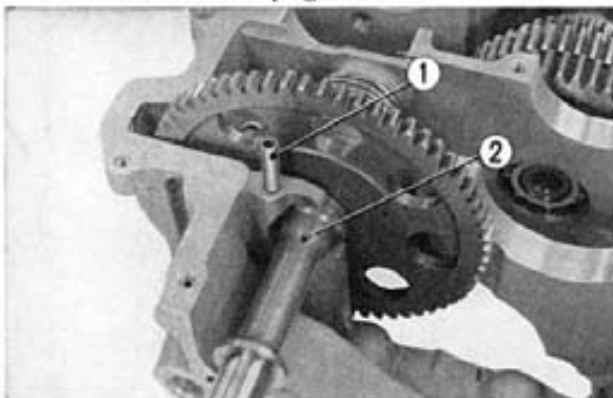


Fig. 3-96 ① Kick spindle stopper pin
② Kick starter spindle

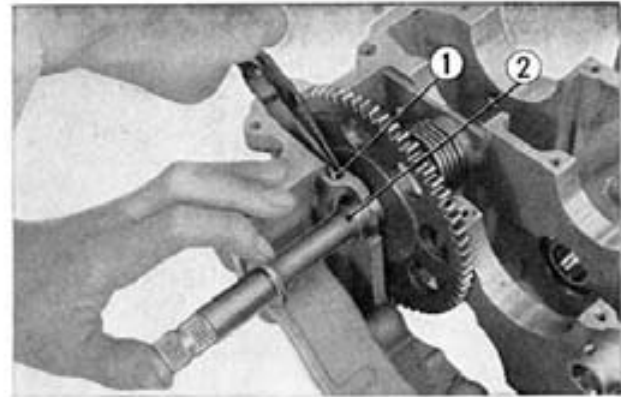


Fig. 3-92 ① Kick starter shaft stopper pin
② Kick starter shaft

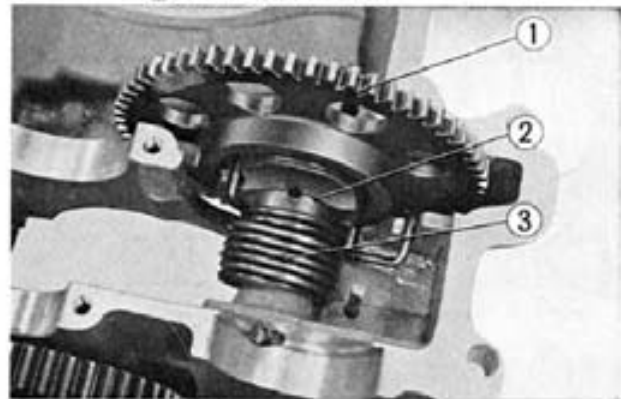


Fig. 3-93 ① Kick starter gear
② Kick starter flange
③ Kick starter return spring

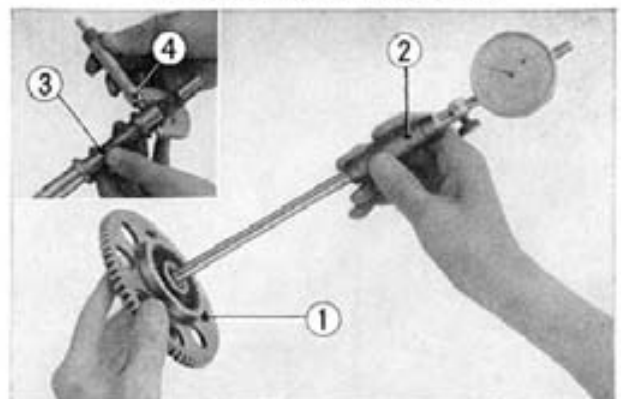


Fig. 3-94 ① Kick gear ③ Kick starter shaft
② Inside dial gauge ④ Micrometer

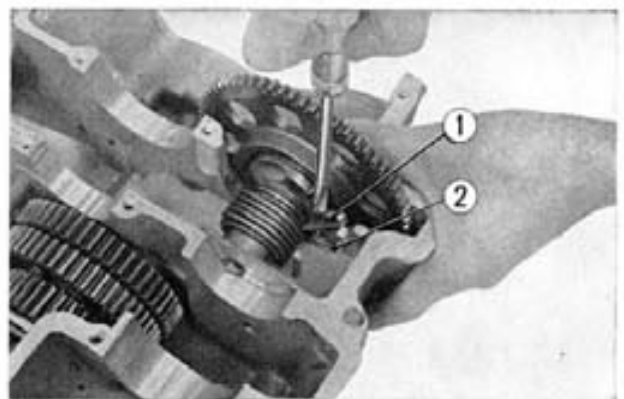


Fig. 3-95 ① Kick starter flange
② Return spring

CLUTCH

GROUP

4

CONTENTS

| | |
|------------------------------|----|
| 4-1 GENERAL DESCRIPTION..... | 58 |
| DESCRIPTION..... | 58 |
| SPECIFICATIONS..... | 58 |
| DIAGNOSIS..... | 58 |
| 4-2 REPAIRING PROCEDURE..... | 59 |
| a. Disassembly..... | 59 |
| b. Inspection..... | 60 |
| c. Reassembly..... | 60 |

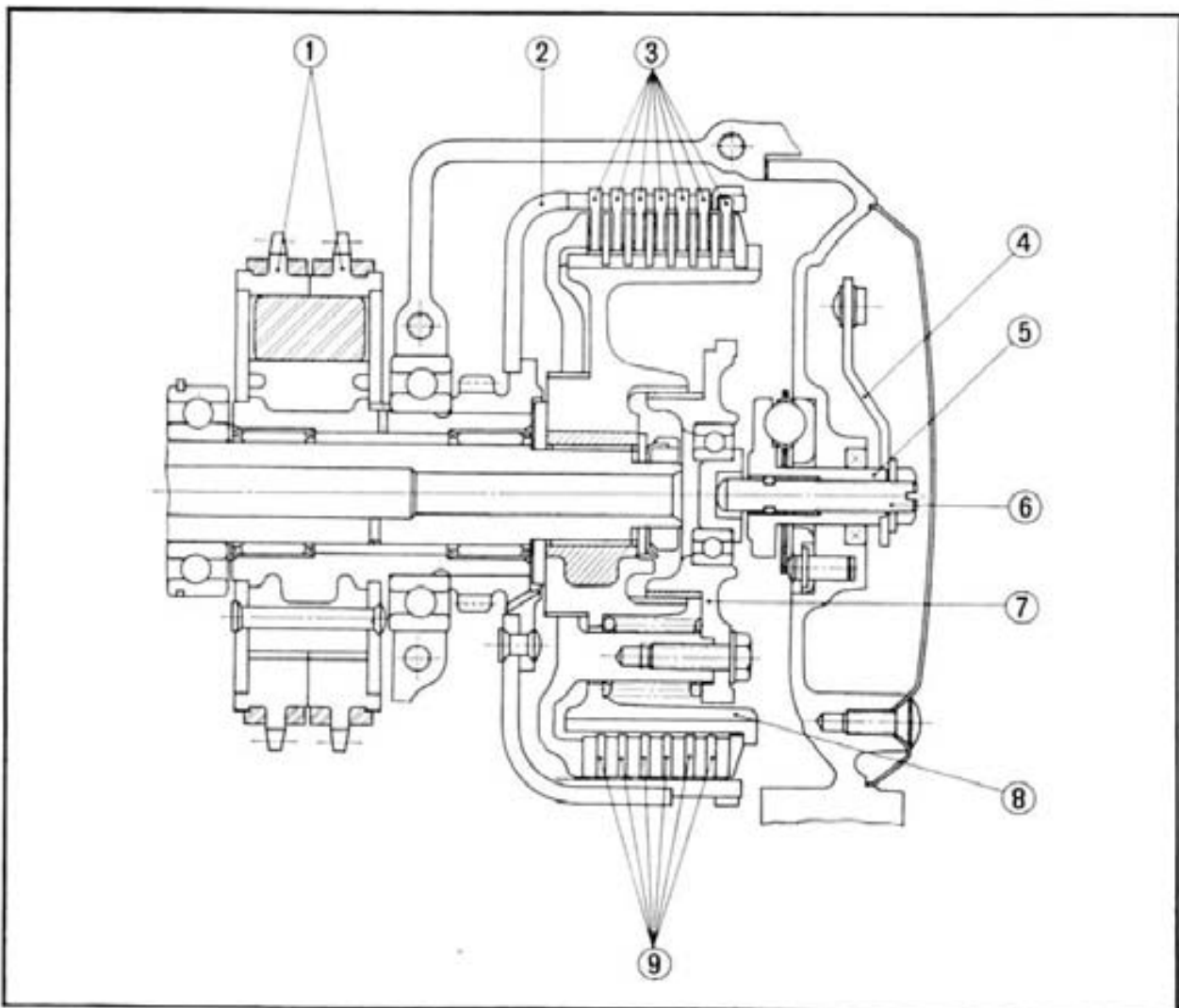


Fig. 4-1 ① Primary driven sprocket ④ Clutch lever ⑦ Clutch lifter plate
② Clutch outer ⑤ Clutch release lever ⑧ Clutch center
③ Friction disc ⑥ Clutch adjusting bolt ⑨ Clutch plate

4-1 GENERAL DESCRIPTION

DESCRIPTION

The function of the clutch is to transmit power from the crankshaft to the transmission mainshaft by the friction between the clutch friction discs and clutch plates.

The clutch is a multiple disc wet type clutch with a friction disc bonded to a core having a good heat dissipating characteristic.

The wet type clutch is lubricated by oil which also serves to dissipate the heat generated by the clutch. Friction discs have long life due to minimum of wear.

The clutch consists of seven cork mold discs, six clutch plates and four clutch springs, contained within the clutch outer. The torque applied at the clutch lever rotates the clutch release lever which moves inward to disengage the clutch. The actuation of clutch can be adjusted by the clutch adjusting bolt. (Fig. 4-1)

SPECIFICATIONS

| Item | Standard value | Serviceable limit |
|---|--|------------------------------------|
| Friction disc thickness | 0.1347~0.1409 in. 3.42~3.58 mm | 0.122 in. 3.1 mm |
| Clutch spring free length | 1.2575 in. 31.94 mm | 1.201 in. 30.5 mm |
| Clutch spring load | 214.3~226.7 lbs/0.984 in. 97.2~102.8 kg/25 mm | 198.5 lbs/0.984 in. 90 kg/25 mm |
| Clutch lever free play at the lever end | 0.4~1.0 in. 10~25 mm | — |

DIAGNOSIS

| Trouble | Probable Causes | Remedy |
|------------------------|--|--|
| Clutch slippage | <ol style="list-style-type: none"> No play in the clutch lever Weak or none uniform clutch pressure plate spring Worn or glazed friction disc | Adjust the clutch lever. Replace the weak spring. Replace. |
| Poor clutch engagement | <ol style="list-style-type: none"> Excessive clutch lever play Warped friction disc Warped pressure plate Bent main shaft | Adjust clutch lever. Replace. Replace. Replace. |

4-2 REPAIRING PROCEDURE

a. Disassembly

1. Remove the clutch cover and disconnect the clutch cable from the clutch lever. Remove the clutch case mounting screw, and remove the case. (Fig. 4-2)
2. Unscrew the four clutch lifter mounting bolts and remove the clutch lifter plate and spring. (Fig. 4-3)
3. Remove the clutch lock nut using the lock nut box wrench (Tool No. 07916-2830000) and then remove the tongued washer and spring washer, followed by the clutch center. (Fig. 4-4)

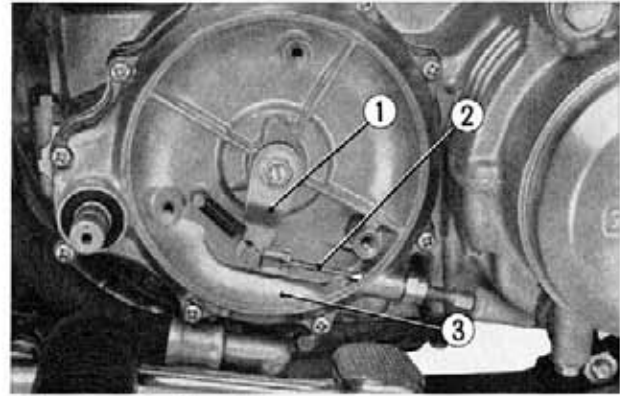


Fig. 4-2 ① Clutch lever
② Clutch cable
③ Clutch case

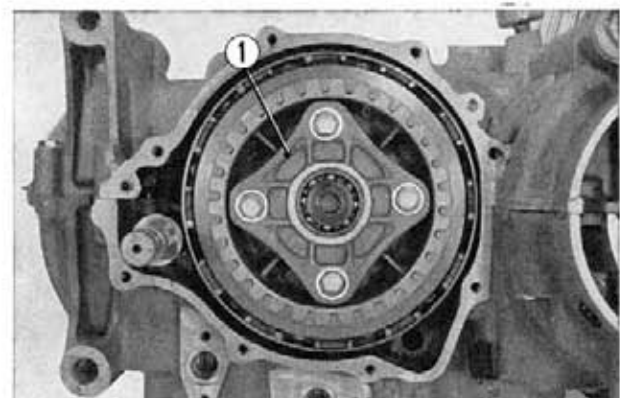


Fig. 4-3 ① Clutch lifter plate

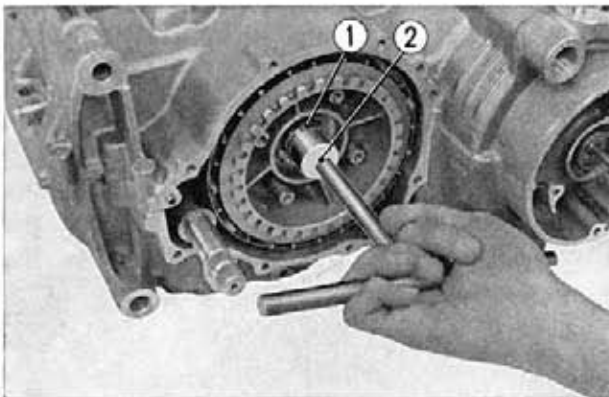


Fig. 4-4 ① Clutch lock nut
② Box wrench

4. Remove the clutch friction disc B and clutch outer ring from the clutch outer and then remove the friction discs A and clutch plates. (Fig. 4-5)
5. Remove the clutch washer, clutch pressure plate and pull off the clutch outer from the main shaft.

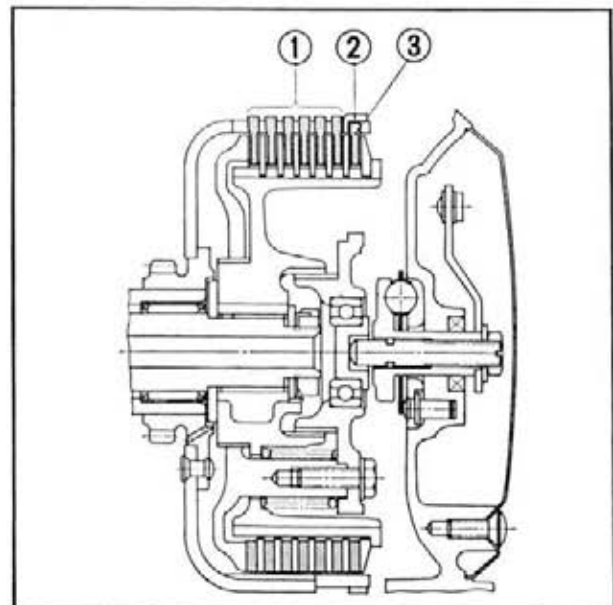


Fig. 4-5 ① Clutch friction disc A
② Clutch outer ring
③ Clutch friction disc B

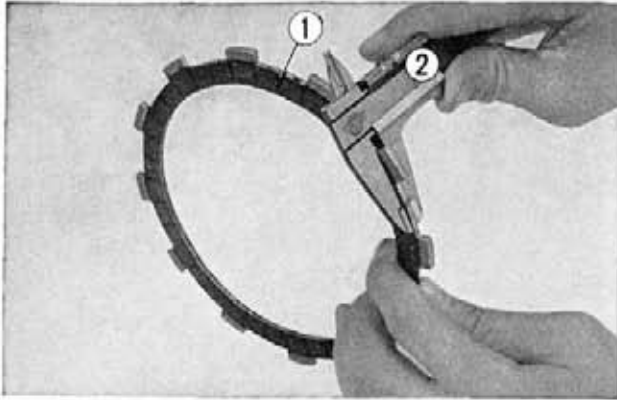


Fig. 4-6 ① Friction disc
② Vernier caliper

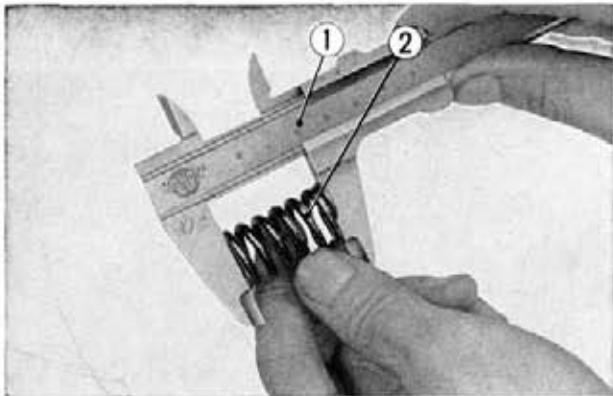


Fig. 4-7 ① Vernier caliper
② Clutch spring

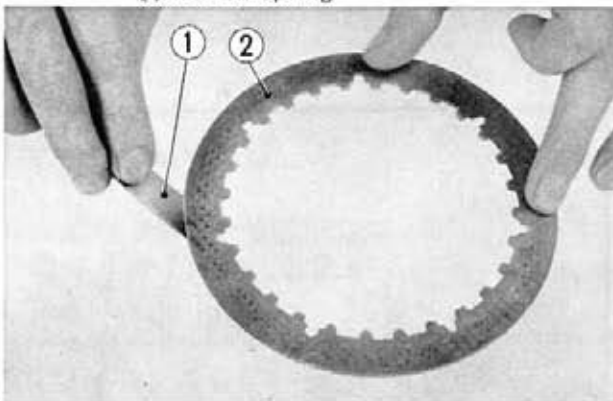


Fig. 4-8 ① Thickness gauge
② Clutch plate

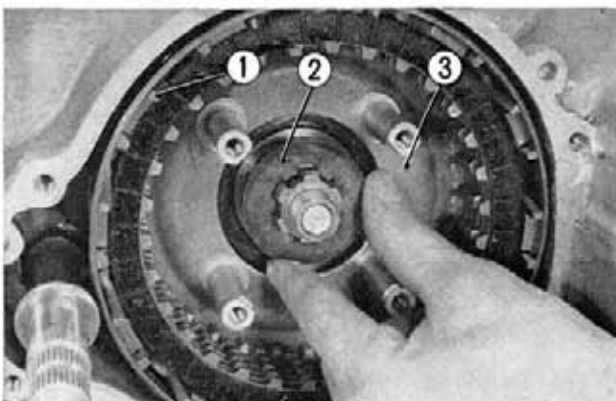


Fig. 4-9 ① Clutch outer
② 25 mm spline washer
③ Clutch pressure plate

b. Inspection

1. Clutch friction disc.

Use a vernier caliper and if the thickness is less than **0.122 in. (3.10 mm)**, replace the disc. It should also be replaced if the clutch plate is warped in excess of **0.012 in. (0.3 mm)** (Fig. 4-6)

2. Clutch spring

Measure the free length of the clutch spring and if it is less than **1.2 in. (30.5 mm)**, it should be replaced. All four springs should be of the same length. (Fig. 4-7)

3. Clutch plate warpage

Measure the warpage of the clutch plate on the surface plate using a thickness gauge. If the warpage is over **0.012 in. (0.3 mm)**, repair or replace. (Fig. 4-8)

c. Reassembly

1. Assemble the clutch outer and the 25 mm spline washer on the main shaft. Hook the washer on the spline and assemble the clutch pressure plate. (Fig. 4-9)

2. Assemble the six friction discs A (outer diameter 151 mm), clutch plates and the clutch center into the clutch outer and then install the clutch outer ring. (Fig. 4-5)

Note : Clutch outer ring tabs should be installed into the friction disc tab groove of the clutch outer.

3. Assemble the friction disc B (outer diameter 148.5 mm). (Fig. 4-5)



4. Assemble the clutch center, the spring washer (tab toward the front), lock washer and lock nut in that order. And torque with a lock nut box wrench (Tool No. 07916-2830000) to **32.5~36.2 ft-lbs (4.5~5.0 kg-m)**. Refer to Fig. 4-10 for the installation of the spring washer.
5. Assemble the four clutch springs and mount in place with the four clutch lifter bolts.
6. Refer to page 183 for clutch adjustment.

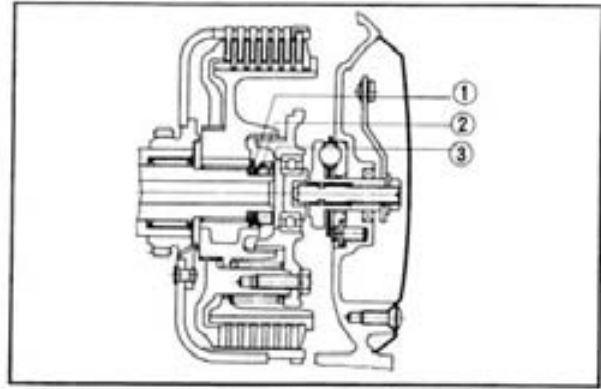


Fig. 4-10 ① Spring washer ② Lock washer ③ Lock nut

TRANSMISSION

GROUP

5

CONTENTS

| | |
|-------------------------------|----|
| 5-1 GENERAL DESCRIPTION | 64 |
| DESCRIPTION | 64 |
| SPECIFICATIONS | 64 |
| DIAGNOSIS | 65 |
| 5-2 REPAIRING PROCEDURE | 65 |
| a. Disassembly | 65 |
| b. Inspection | 66 |
| c. Reassembly | 68 |

5-1 GENERAL DESCRIPTION

DESCRIPTION

The 5-speed, constant mesh transmission is incorporated in the transmission compartment of the lower crankcase.

The relative positions of the transmission at the respective changing position are shown below. (Fig. 5-1)

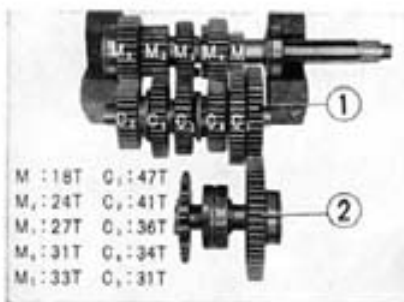


Fig. 5-1A

- ① Final drive gear (47T)
- ② Final driven gear (56T)

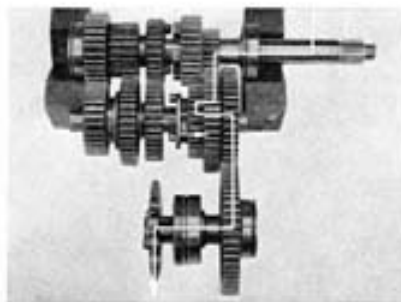


Fig. 5-1B

1st gear (C₄ gear shifted)

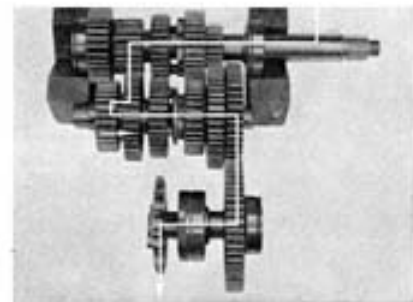


Fig. 5-1C

2nd gear (C₅ gear shifted)

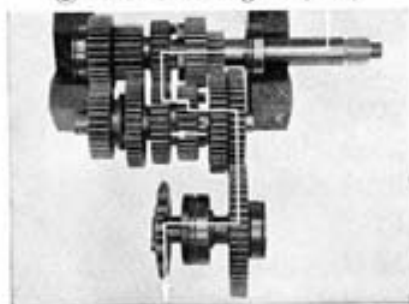


Fig. 5-1D

3rd gear (C₄ gear shifted)

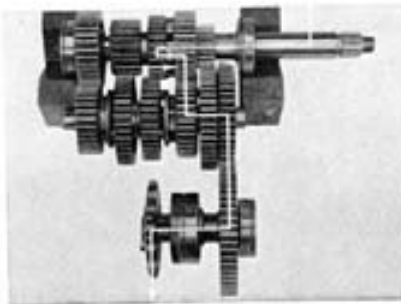


Fig. 5-1E

4th gear (M₂-M₃ gear shifted)

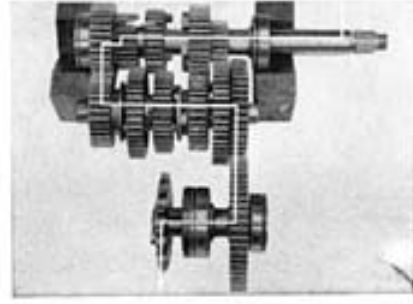
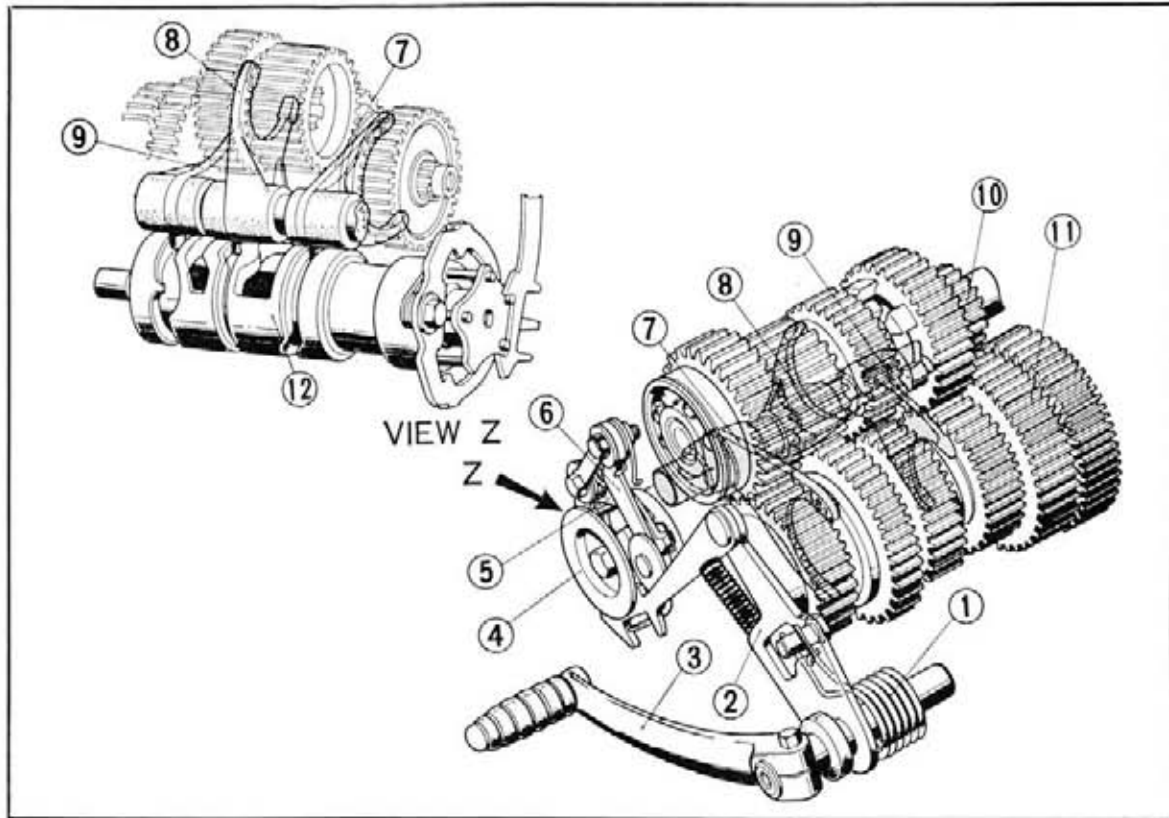


Fig. 5-1F

5th gear (M₂-M₃ gear shifted)

The gear shift mechanism consists of three gear shift forks, a gear shift drum, a gear shift arm, a shift drum stopper and a gear shift positive stopper.

When the gear change pedal is depressed the gear shift spindle rotates, causing the gear shift arm to rotate the shift drum. When the shift drum rotates, the shift forks move sideways by the cam action of groove cut on the shift drum body. (Fig. 5-2)



- | | | |
|----------------------------|-------------------------------|-----------------------------|
| ① Gear shift return spring | ⑤ Gear shift positive stopper | ⑨ Right gear shift fork |
| ② Gear shift spindle | ⑥ Shift drum stopper | ⑩ Transmission mainshaft |
| ③ Gear change pedal | ⑦ Left gear shift fork | ⑪ Transmission countershaft |
| ④ Gear shift side plate | ⑧ Center gear shift fork | ⑫ Gear shift drum |

Fig. 5-2

SPECIFICATIONS

| | |
|---------------------------|-------|
| Gear ratio | |
| 1st (low) | 2.500 |
| 2nd | 1.708 |
| 3rd | 1.333 |
| 4th | 1.097 |
| 5th (top) | 0.939 |
| Primary reduction ratio | 1.708 |
| Secondary reduction ratio | 1.167 |
| Final reduction ratio | 2.812 |

DIAGNOSIS

| Trouble | Probable Causes | Remedy |
|----------------------------------|---|---|
| Difficult gear shifting | <ol style="list-style-type: none"> 1. Improper clutch disengagement 2. Damage gear or foreign object lodged in the gear 3. Gear shift fork inoperative 4. Improper operation of the gear shift drum stopper and change pedal 5. Mainshaft and countershaft of alignment 6. High oil viscosity | <p>Adjust the clutch (Refer to page 183).</p> <p>Replace the defective parts.</p> <p>Repair or replace.</p> <p>Repair or replace.</p> <p>Repair or replace.</p> |
| Excessive high gear noise | <ol style="list-style-type: none"> 1. Excessive gear backlash 2. Worn main and countershaft bearing | <p>Repair or replace.</p> <p>Repair or replace.</p> |
| Gear slip out | <ol style="list-style-type: none"> 1. Worn fingers on gear shift fork 2. Worn gear dog hole 3. Worn spline | <p>Replace.</p> <p>Replace.</p> <p>Replace.</p> |

5-2 REPAIRING PROCEDURE

a. Disassembly

1. Disassemble the cylinder head, cylinder and cam chain tensioner in accordance with section 3-3 b on page 32~35.
2. Disassemble the crankcase in accordance with section 3-6 b on page 46~47.
3. Raise the transmission mainshaft and remove the primary sprocket and then remove the mainshaft gear assembly from the upper crankcase. (Fig. 5-3)
4. Remove the final shaft oil guide and the final shaft assembly from the upper crankcase. (Fig. 5-4).

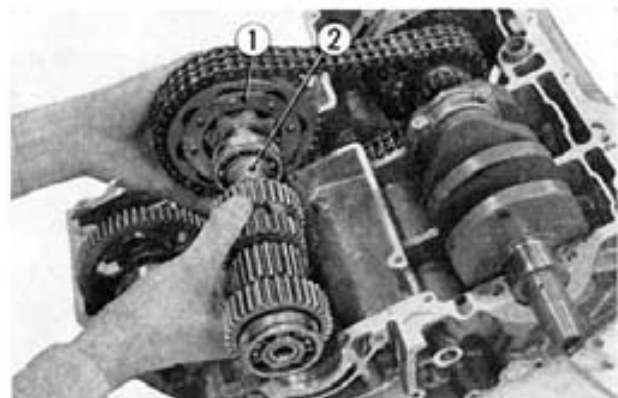


Fig. 5-3 ① Primary sprocket
② Transmission mainshaft

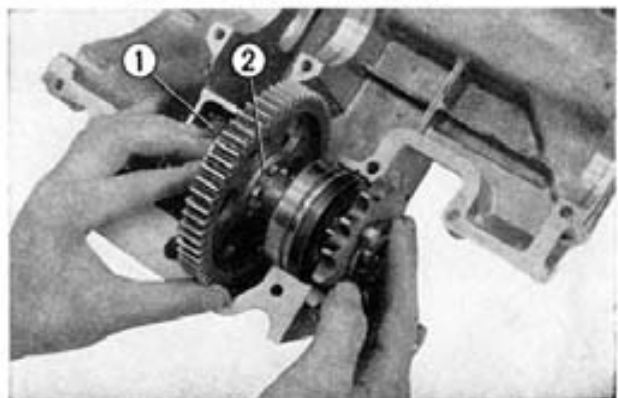


Fig. 5-4 ① Final shaft oil guide
② Final shaft assembly

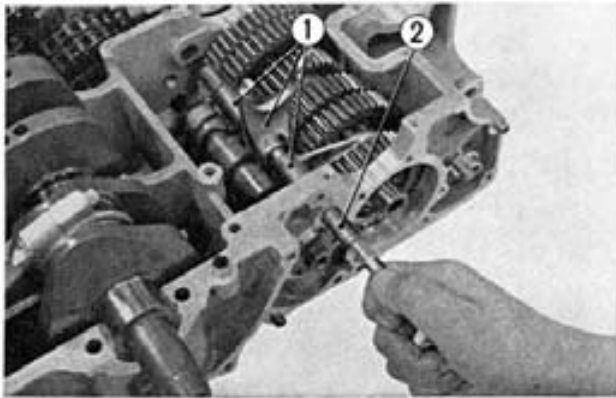


Fig. 5-5 ① Gear shift forks
② Gear shift fork shaft

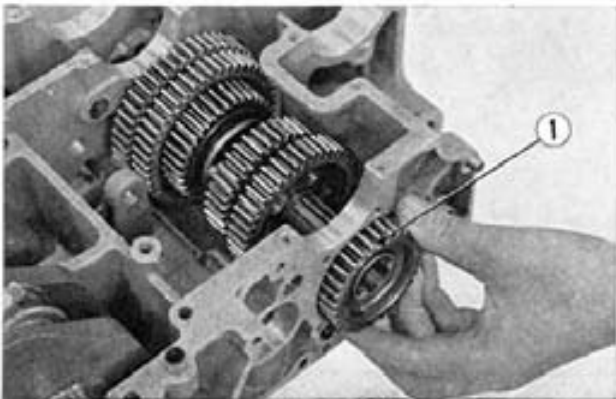


Fig. 5-6 ① Countershaft top gear

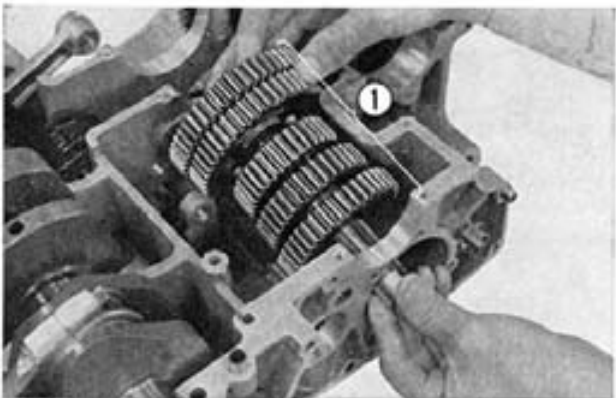


Fig. 5-7 ① Countershaft gear assembly

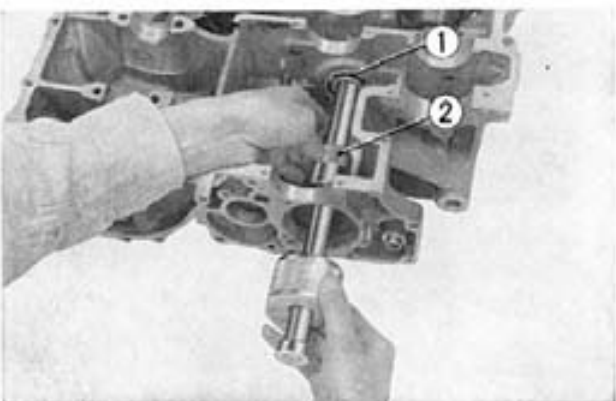


Fig. 5-8 ① Countershaft bearing
② Bearing puller

5. Pull off the gear shift fork shaft and remove the shift forks. (Fig. 5-5)
6. Unscrew the neutral stopper bolt, remove the stopper and take out the gear shift drum from the crankcase.
7. Remove the countershaft top gear. (Fig. 5-6)
8. Take out the countershaft gear assembly from the lower crankcase. (Fig. 5-7)
9. Pull out the countershaft right bearing from the lower crankcase using the bearing puller (Tool No. 07048-30025). (Fig. 5-8)
10. Disassemble gears from the respective shafts in accordance with Fig. 5-17 on page 61.

b. Inspection

1. Gear backlash (Fig. 5-9)

Using a small dial gauge and apply the pointer against the surface of the teeth. Lock the mating gear and read the dial indication as the backlash is being checked. If the backlash is beyond the tolerance shown below, the gears or the shafts should be replaced in pair.

| Gear | Standard value in. (mm) | Serviceable limit in. (mm) |
|-----------------------------|--------------------------------|-------------------------------|
| 1st gear | 0.0017~0.0052 (0.044~0.140) | 0.008 (0.2) |
| 2nd, 3rd, 4th & 5th gear | 0.0018~0.0055 (0.046~0.140) | 0.008 (0.2) |

2. Gear locking dog

Check the dogs on the respective gears and if excessively worn or damaged, the gear should be replaced. Also check to see if the gears are sliding smoothly.

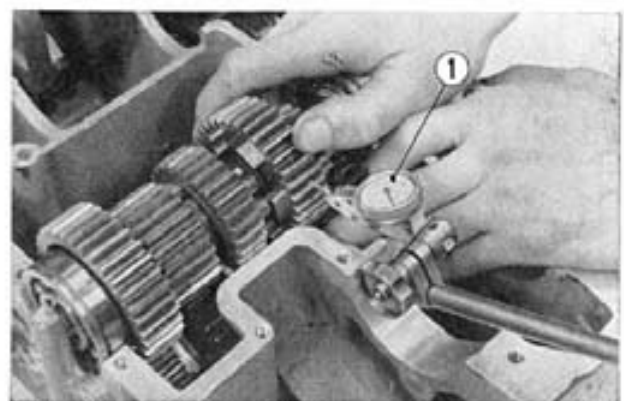


Fig. 5-9 ① Small dial gauge

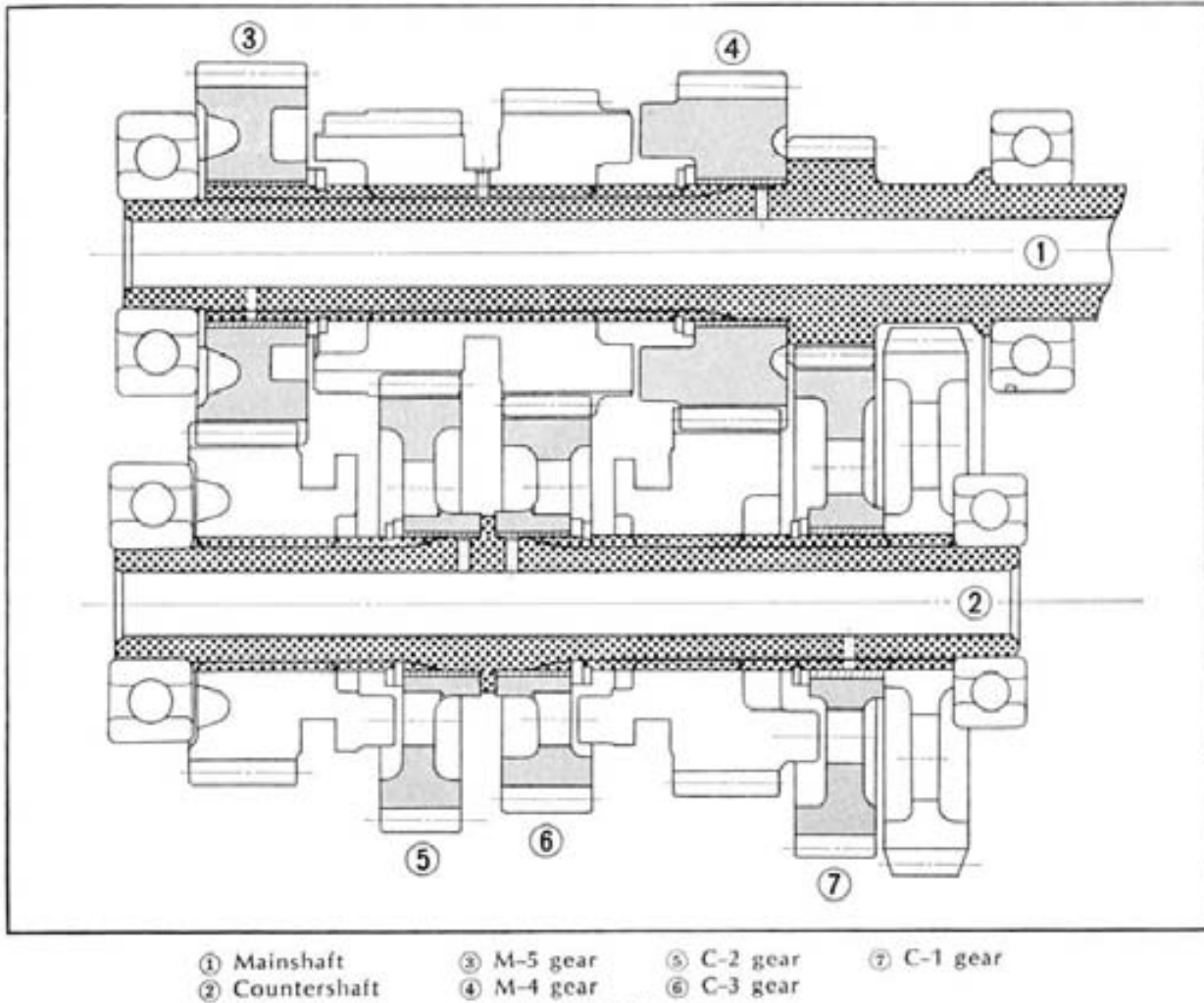


Fig. 5-10

3. Gear to shaft clearance (Fig. 5-10)

Check the gear bore with an inside micrometer or a cylinder gauge and check the shaft with a micrometer. Make sure that the measured values are within the tolerance indicated below.

| Item | Standard value in. (mm) | Serviceable limit in. (mm) |
|--|-------------------------------|-----------------------------------|
| C ₁ , C ₂ , C ₃ , M ₄ M ₅ gear | 0.0016~0.0032 (0.04~0.082) | Replace if over 0.0072 (0.182) |

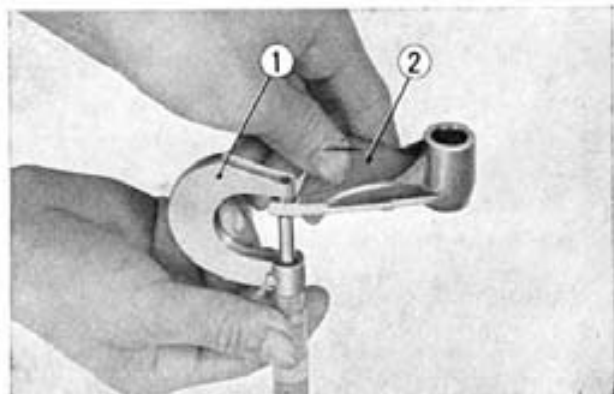


Fig. 5-11 ① Micrometer
② Gear shift fork

4. Gear shift fork

Check the fingers on the gear shift fork using a micrometer and if worn beyond **0.240 in. (6.1 mm)**, or if the shift fork dog is worn to less than **0.260 in. (6.6 mm)** diameter, the shift fork should be replaced. (Fig. 5-11).

5. Gear shift fork inside diameter

Check the inside diameter of the gear shift fork with a inside micrometer and if it is **greater than 0.5134 in. (13.04 mm)** it should be replaced. Gear shift fork shaft is checked

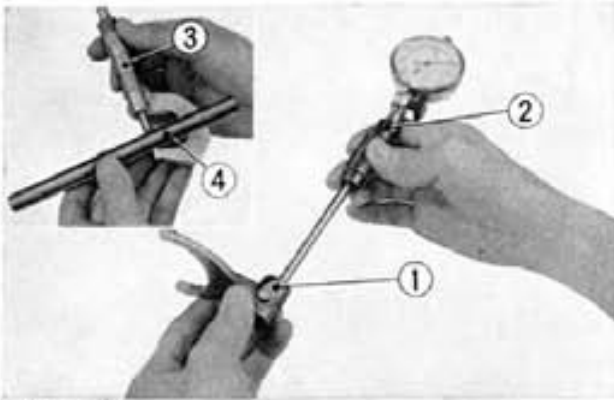


Fig. 5-12

- ① Gear shift fork ③ Micrometer
 ② Inside dial gauge ④ Gear shift fork shaft

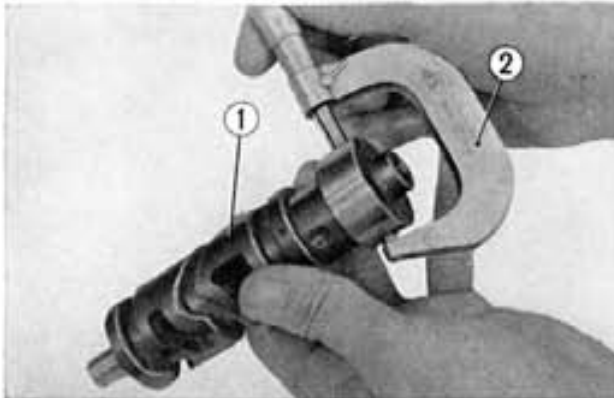
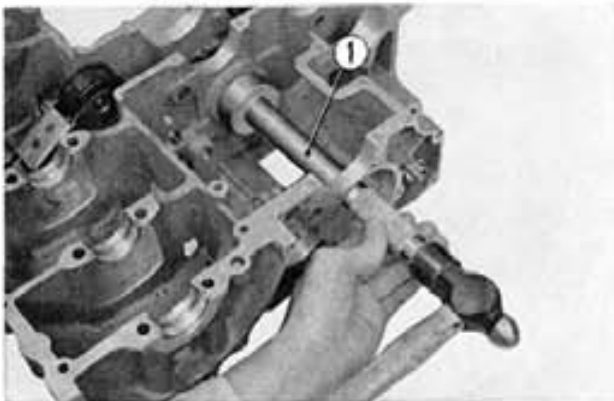
Fig. 5-13 ① Gear shift drum
② Micrometer

Fig. 5-14 ① Bearing driver tool

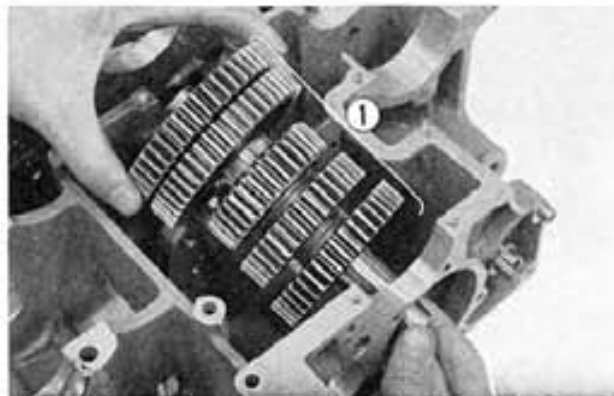


Fig. 5-15 ① Countershaft gear assembly

with a micrometer and if it is worn to less than 0.5079 in. (12.9 mm), it should be replaced. (Fig. 5-12)

6. Gear shift drum

Check the outside diameter of the gear shift drum with a micrometer and if it is worn below the values indicated below, it should be replaced. (Fig. 5-13)

| | |
|------------|-----------------------|
| Right side | 0.5154 in. (11.95 mm) |
| Left side | 1.4142 in. (35.92 mm) |

c. Reassembly

1. Mount the primary chain tensioner on the lower crankcase.
2. Assemble the gears on to the respective shafts. Use all new circlips and make sure that they are seated properly in the grooves. Refer to Fig. 5-17 (next page) for the proper installation of the gears and circlips.
3. Drive the counter shaft bearing into the lower crankcase using the bearing driver (Tool No. 07949-3000000). (Fig. 5-14)
4. Mount the countershaft gear assembly into the crankcase, however, the C-5 gear must be left off and assembled later from the outside of the crankcase. (Fig. 5-15)
5. Mount the gear shift drum and install the neutral stopper with a bolt. Neutral position on the drum is at the depression on the drum.
6. Gear shift forks are stamped with the letters "R", "C" and "L" on the side. Assemble the forks as shown in Fig. 5-16. The forks stamped with "R" and "L" are for use with the countershaft, therefore, the fingers of those forks are fitted into the groove in the C-4 and C-5 gears. The "C" stamped fork is used with M-2/3 gear. The dog located on the back side of the fork is fitted into the groove in the gear shift drum.

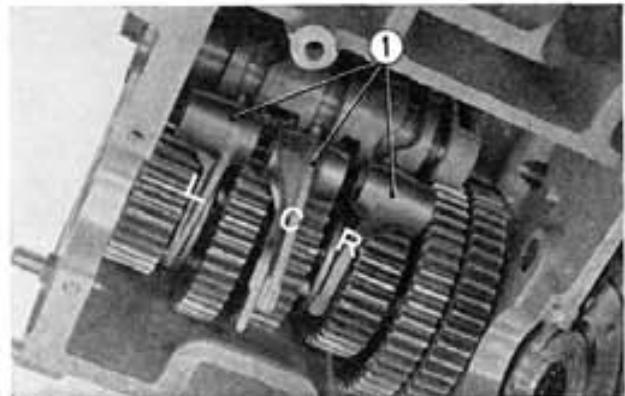
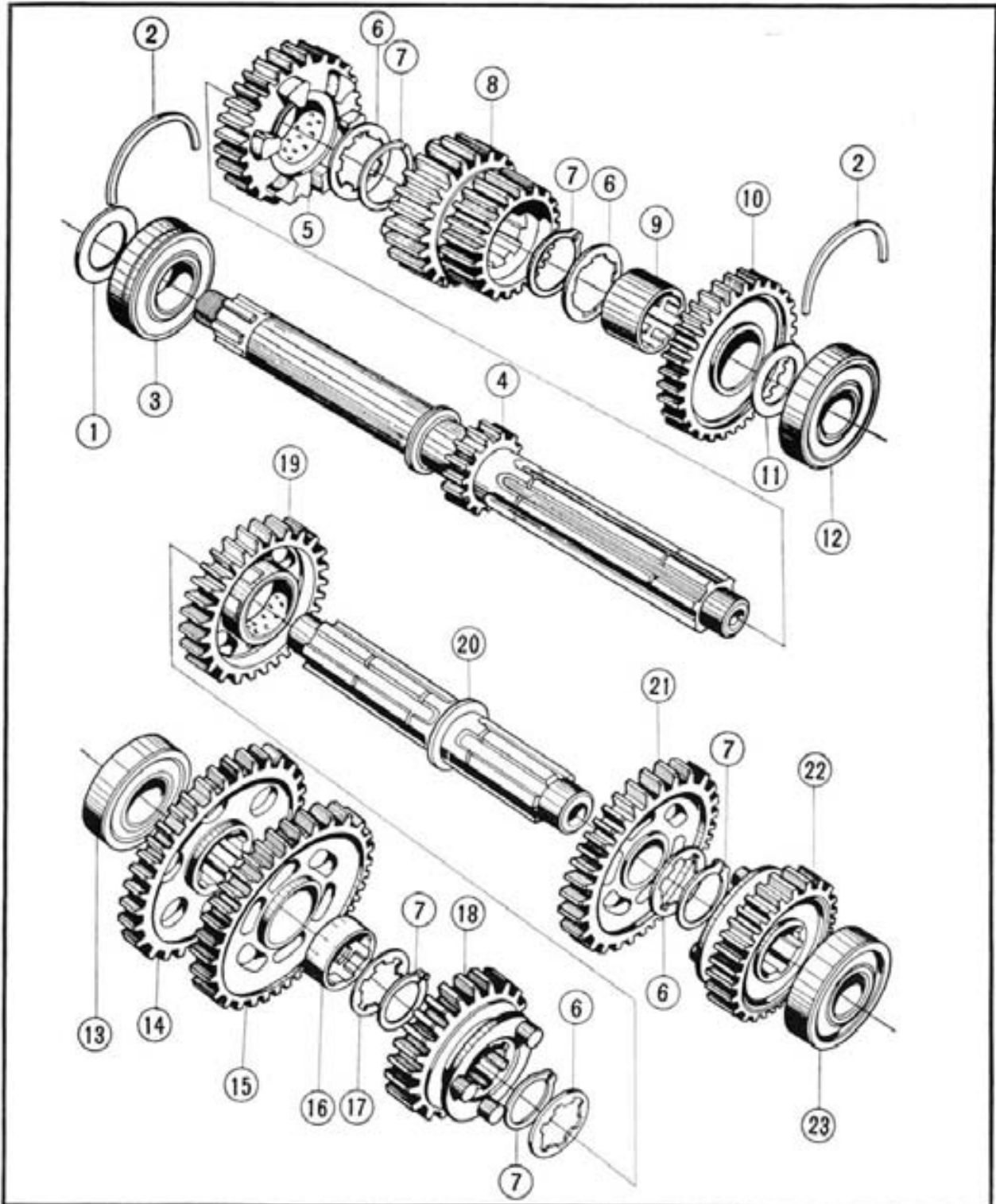


Fig. 5-16 ① Gear shift forks



- ① 25 mm thrust washer
- ② Ball bearing set ring A
- ③ 6205 special ball bearing
- ④ Transmission mainshaft
- ⑤ Mainshaft fourth gear (37 T)
- ⑥ 25 mm thrust washer
- ⑦ 25 mm cir-clip
- ⑧ Mainshaft second & third gear (24 T & 27 T)

- ⑨ 28×20.5 bush
- ⑩ Mainshaft top gear (33 T)
- ⑪ 20 mm thrust washer
- ⑫ 6304 HS radial ball bearing
- ⑬ N-6304 radial ball bearing
- ⑭ Final drive gear (48 T)
- ⑮ Counter shaft low gear (47 T)
- ⑯ 28×14 bush
- ⑰ 25×33 thrust washer

- ⑱ Countershaft fourth gear (34 T)
- ⑲ Countershaft third gear (36 T)
- ⑳ Transmission countershaft
- ㉑ Countershaft second gear (41 T)
- ㉒ Countershaft top gear (31 T)
- ㉓ 6204 ball bearing

Fig. 5-17

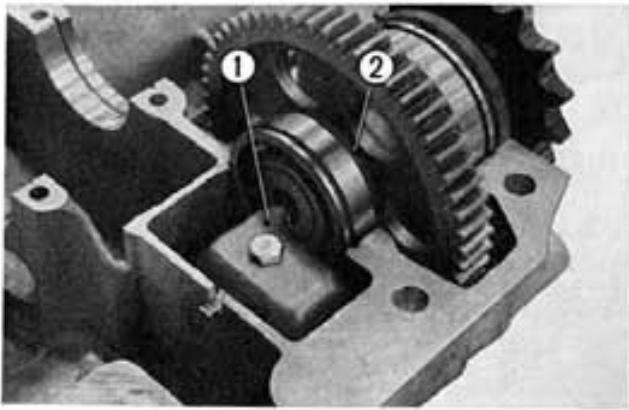


Fig. 5-18 ① Final shaft oil guide
② Final driven shaft

7. Install the final shaft assembly into the upper crankcase; do not forget the set ring and install the final shaft oil guide (Fig. 5-18).
8. Mount the primary sprocket on the transmission mainshaft assembly and install the complete unit into the upper crankcase.
9. Install the two dowel pins, oil collar and "O" ring in the upper crankcase, apply liquid packing on the mounting flange, and assemble the lower crankcase.
At this time, all the gears must be in neutral position and the center gear shift fork must be inserted into the M-2/3 gear groove.
10. Install the crankcase in accordance with 3-6 d on page 51~52.
11. Install the camchain tensioner, cylinder and cylinder head by referring to section 3-3 d on page 36-38.

FUEL SYSTEM

GROUP

6

CONTENTS

| | |
|--------------------------------------|-----------|
| 6-1 GENERAL DESCRIPTION | 71 |
| DESCRIPTION | 71 |
| SPECIFICATIONS | 72 |
| DIAGNOSIS..... | 73 |
| 6-2 CARBURETOR | 74 |
| a. Description..... | 74 |
| b. Disassembly | 75 |
| c. Inspection..... | 76 |
| d. Reassembly..... | 77 |
| 6-3 FUEL TANK AND VALVE..... | 81 |
| a. Description..... | 81 |
| b. Disassembly | 82 |
| c. Inspection..... | 82 |
| d. Reassembly..... | 82 |

6-1 GENERAL DESCRIPTION

DESCRIPTION

The two fuel tubes connected to the fuel valve supply the fuel from the fuel tank to the four carburetors.

The fuel in the carburetor float chamber is sucked into the engine in the proper air-fuel mixture to conform with the engine speed. This has a great influence on the engine performance.

In an engine with four independent carburetors their precise adjustment is particularly important for smooth operation.

The fuel valve has three positions, ON, STOP and RES ; which can be selected by the lever.

SPECIFICATIONS

| | |
|----------------------------|-----------------------|
| Fuel tank capacity | 4.7 U.S gal. (18 lit) |
| Fuel tank reserve capacity | 10.5 U.S pt. (5 lit.) |

Carburetor setting table

| | | |
|-------------------|---|------------------------|
| Type | Piston valve, 4 pcs. | |
| Main bore | 1.102 in. (28 mm) | |
| Main jet | # 120 | |
| Air jet | # 100 | |
| Air bleed | AB 1 | 0.035 in. (0.9 mm) × 4 |
| | AB 2 | 0.035 in. (0.9 mm) × 4 |
| | AB 3 | 0.024 in. (0.6 mm) × 2 |
| | AB 4 | 0.024 in. (0.6 mm) × 2 |
| Needle jet | 0.102 × 0.15 in. (7.6 × 3.8 ^{mm}) | |
| Jet needle | 0.098 in. (2.485 mm) | |
| Cutaway | # 2.5 [recess 0.047 mm (1.2 mm), depth 0.008 in (0.2 mm)] | |
| Air screw opening | 1 ± 1/8 | |
| Slow jet | # 40 | |
| Valve seat | 0.079 in. (2 mm) | |
| Pilot outlet | 0.047 in. (1.2 mm) | |
| Setting mark | B 750 A | |



DIAGNOSIS

| Trouble | Probable Causes | Remedy |
|-----------------------------------|--|---|
| Engine does not start | <ol style="list-style-type: none"> 1. Choke open to wide 2. Carburetor air screw opened too far 3. Air leaking into the cylinder head 4. Clogged carburetor slow jet 5. Clogged fuel valve or piping 6. Clogged vent hole in the fuel filler cap 7. No fuel in the tank | <p>close choke. Adjust air screw.</p> <p>Retighten carburetor connecting tube.</p> <p>Check, clean and retighten.</p> <p>Disassemble and clean.</p> <p>Disassemble and clean.</p> <p>Fill tank with gasoline.</p> |
| Poor engine idling | <ol style="list-style-type: none"> 1. Clogged or loose carburetor slow jet 2. Improper float level 3. Improper air screw adjustment 4. Improper carburetor linkage operation 5. Air leaks | <p>Check, clean and retighten.</p> <p>Adjust (Refer to page 68).</p> <p>Adjust (Refer to page 71~73).</p> <p>Adjust.</p> <p>Tighten all air passage connection.</p> |
| Improper running of engine | <ol style="list-style-type: none"> 1. Jet size too small 2. Improper float level 3. Clogged carburetor main jet 4. Improper carburetor linkage operation 5. Air leaks | <p>Replace larger size jet.</p> <p>Adjust.</p> <p>Clean and retighten.</p> <p>Adjust.</p> <p>Tighten all air passage connection.</p> |

6-2 CARBURETOR

a. Description

The quadruple piston type carburetors are mounted on the cylinder head with a stay plate. Choke lever is a link type which operates all four choke valves simultaneously.

Fig. 6-1 shows the construction details of the carburetor.

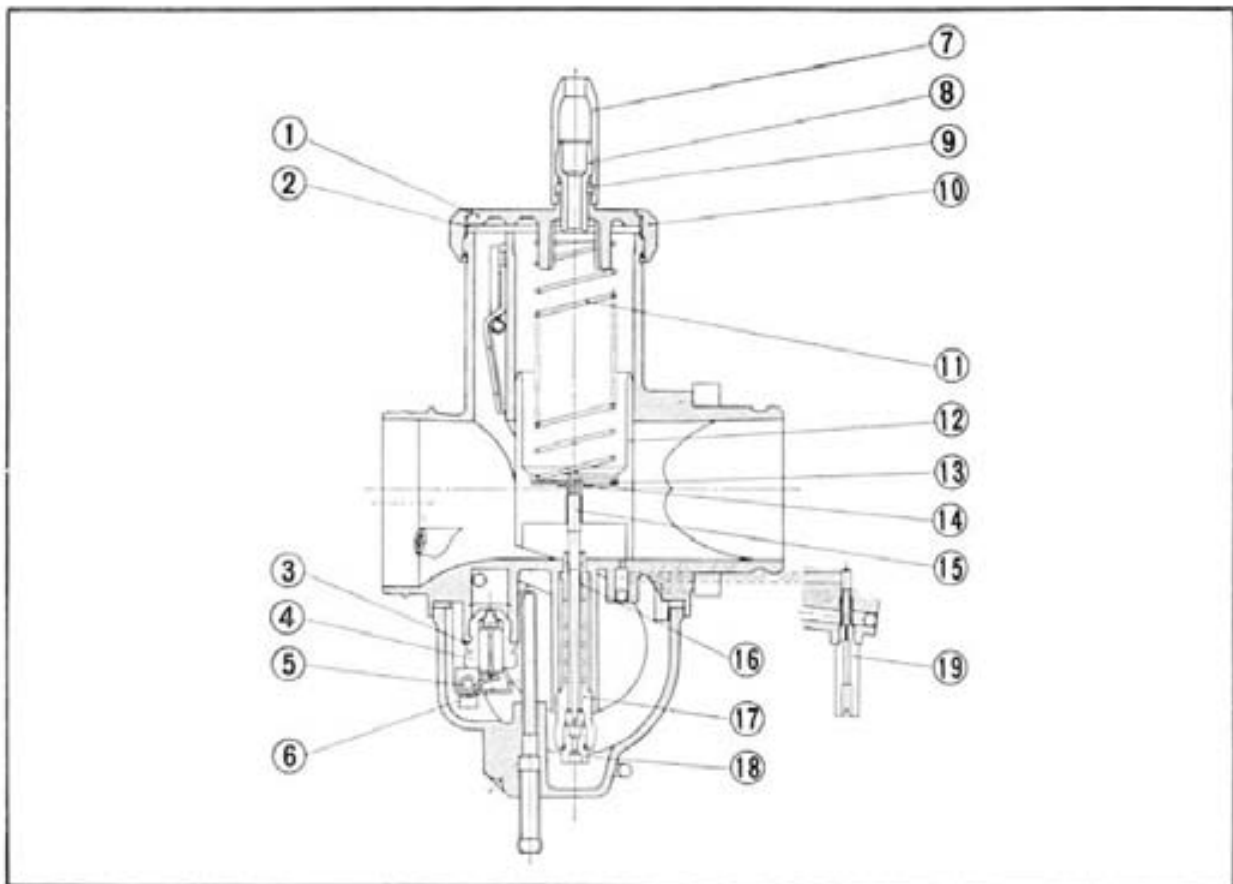


Fig. 6-1

- | | | |
|------------------|--------------------|---------------------|
| ① Carburetor top | ⑧ Cable adjuster | ⑱ Jet needle |
| ② Top washer | ⑨ Lock nut | ⑲ Needle jet |
| ③ Flat washer | ⑩ Cap | ⑳ Needle jet holder |
| ④ Valve seat | ⑪ Throttle spring | ㉑ Main jet |
| ⑤ Float arm pin | ⑫ Throttle valve | ㉒ Slow jet |
| ⑥ Float | ⑬ Needle set plate | |
| ⑦ Rubber cap | ⑭ Clip | |

As the air enters the carburetor, it passes under the throttle valve where vacuum pressure is produced due to the restriction caused by the throttle valve extending into the main air passageway. The fuel discharge outlet is located in this so-called venturi area so that the vacuum pressure can draw out the fuel. This carburetor incorporates both the main and slow system.

• Main system

The fuel passes through the main jet ⑱ and enters the needle jet holder ⑳ where it mixes with the bleed hole located around the needle jet holder. The fuel air mixture passes by the opening between the needle jet ⑲ and jet needle ⑱ and is discharged from

below the throttle valve ⑫.

It is here that the mixture is combined with the main air and after being atomized, is taken in to the engine.

• **Slow system**

The air which enters from the inlet passes through the outside of the air screw where it is metered and enters the slow jet bleed hole. It mixes with the fuel which enters the slow jet ⑬ to produce a full spray that is discharged from the pilot outlet at a point under the throttle valve. This mixes with the air from the air inlet to form a combustible mixture before being taken into the engine.

• **Float chamber**

The carburetor must provide a proper mixture of fuel at different throttle openings and engine speeds; in order to accomplish this, the fuel level in the carburetor must be maintained constant. The float chamber functions to serve this purpose. The fuel from the tank enters the float chamber through the fuel inlet passage, between the float valve seat ④ and float valve and fills the chamber to the level where the float ⑤ rises to shut off the fuel by seating the float valve against the valve seat through the action of the float arm. As the fuel is consumed, the fuel level in the float chamber, drops the float will follow the level, and the fuel will start to enter the chamber between the opening of the float valve and valve seat to maintain a constant fuel level. (Fig. 6-1)

b. Disassembly

1. Turn the fuel tank valve to the "STOP" position, remove the fuel lines from the fuel valve body, raise the seat and pull the rear tank rubber mounting away from the rear tank mount. Remove the fuel tank.
2. Remove the throttle valve from each of the carburetors. (Fig. 6-2)
3. Loosen the air cleaner connecting tube and insulator bands and remove the carburetors as an assembly. (Fig. 6-3)
4. Unscrew the two 6 mm screws and dismount the respective carburetor from the stay plate. (Fig. 6-4)

Disconnecting the individual choke rod will separate the carburetors.

5. In order to remove the needle jet from the throttle valve, first, disconnect the throttle cable from the throttle valve, and then remove the needle set plate from the throttle valve. (Fig. 6-5)

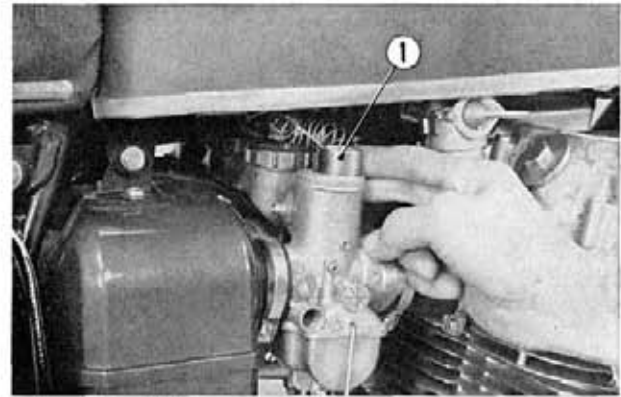


Fig. 6-2 ① Throttle valve

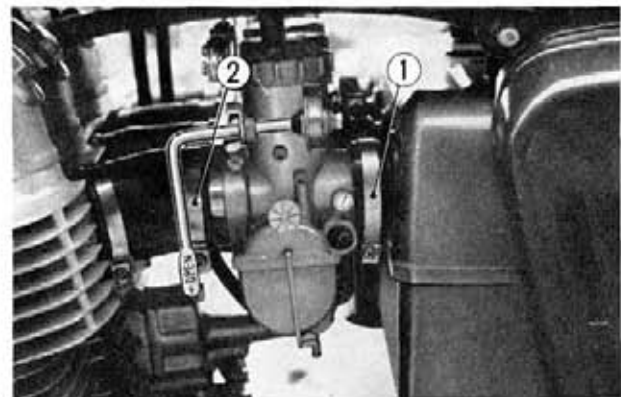


Fig. 6-3 ① Air cleaner connecting band
② Carburetor insulator band

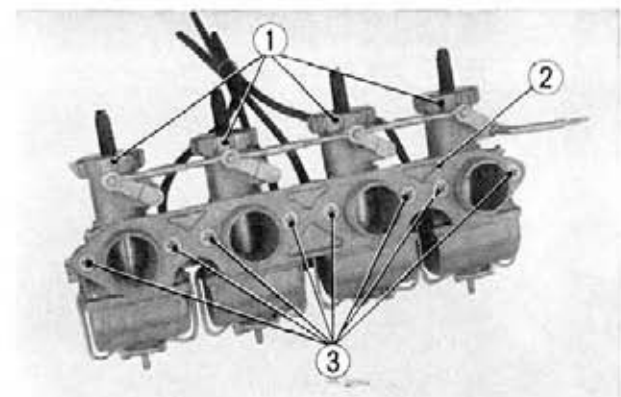


Fig. 6-4 ① Carburetor ③ Setting screws
② Carburetor stay plate

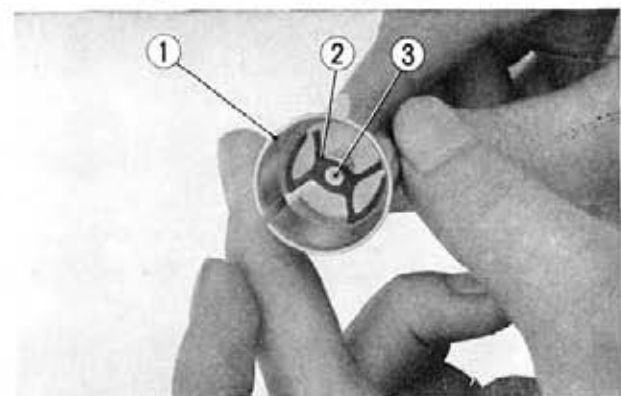


Fig. 6-5 ① Throttle valve ③ Jet needle
② Needle set plate

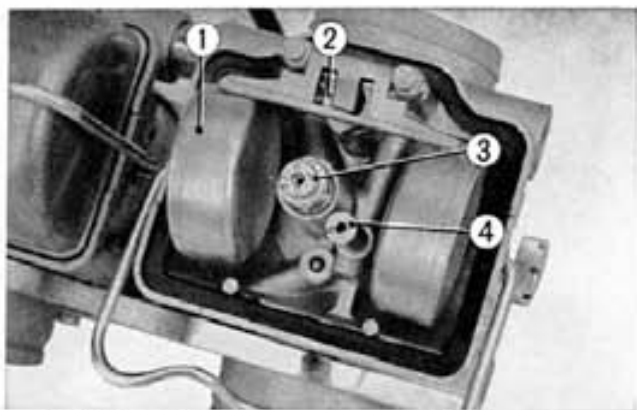


Fig. 6-6 ① Float ② Float valve set ③ Main jet ④ Slow jet

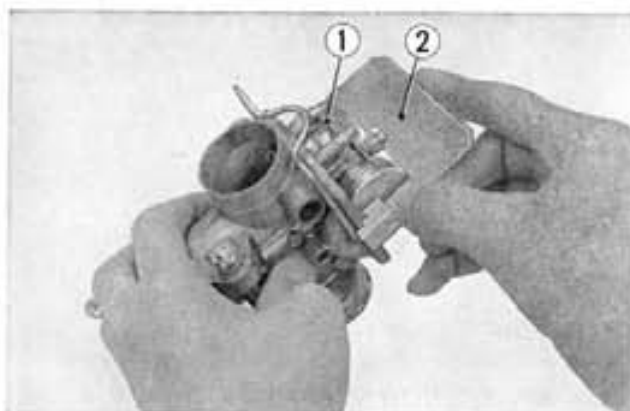


Fig. 6-7 ① Float ② Float level gauge

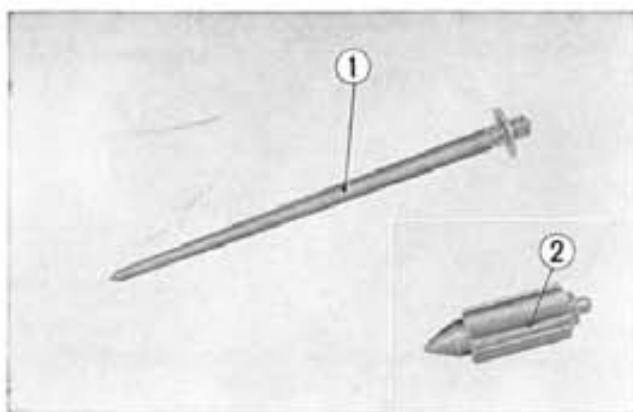


Fig. 6-8 ① Jet needle ② Float valve

6. Remove the float chamber retaining clip and the following carburetor components can be removed with a small screwdriver: slow jet, main jet, needle jet holder, float and float valve set. (Fig. 6-6)

c. Inspection

1. Carburetor adjustment should be made in accordance with the description on page 78~81.

2. Fuel level check

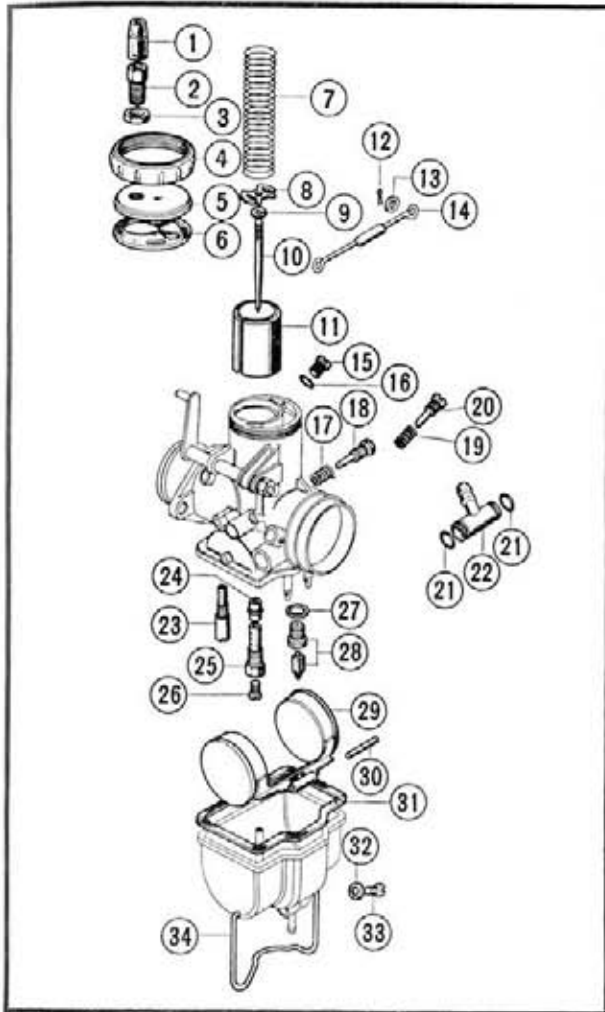
Remove the float chamber and set the float arm as shown in the Fig. 6-7 so that it just barely touches the valve and in this position, check the position of the float with the gauge set vertically. At a standard setting the float should just barely come in contact with the gauge. If there is clearance between the gauge and float or if the float is interfering with the gauge, adjustment should be made. The height of float can be adjusted by bending the float arm using a narrow screwdriver.

3. Jet needle, float valve

The jet needle is constantly moving and if it is found to be excessively worn, it should be replaced. Further, check the wear of the valve and the valve seat and if it is defective, part should be replaced. (Fig. 6-8)

4. The clogging of the respective jet should be cleaned by blowing out the jets with compressed air followed by properly torquing the jets.

d. Reassembly



- | | |
|--------------------|------------------------------|
| ① Rubber cap | ⑱ Air screw |
| ② Cable adjuster | ⑲ Throttle stop screw spring |
| ③ Lock nut | ⑳ Throttle stop screw |
| ④ Cap | ㉑ 7.9×1.9 O-ring |
| ⑤ Top | ㉒ T-type fuel tube joint |
| ⑥ Top washer | ㉓ Slow jet |
| ⑦ Throttle spring | ㉔ Needle jet |
| ⑧ Needle set plate | ㉕ Needle jet holder |
| ⑨ Clip | ㉖ Main jet |
| ⑩ Jet needle | ㉗ Flat washer |
| ⑪ Throttle valve | ㉘ Float valve set |
| ⑫ 1.0×10 split pin | ㉙ Float |
| ⑬ 5 mm flat washer | ㉚ Float arm pin |
| ⑭ Choke rod | ㉛ Float chamber washer |
| ⑮ Plug screw | ㉜ 6 mm flat washer |
| ⑯ Flat washer | ㉝ Drain plug |
| ⑰ Air screw spring | ㉞ Float chamber set clip |

Fig. 6-9

1. Wash all the parts and dry completely with compressed air before reassembly.

Assemble the main jet and slow jet on respective location. (Fig. 6-10)

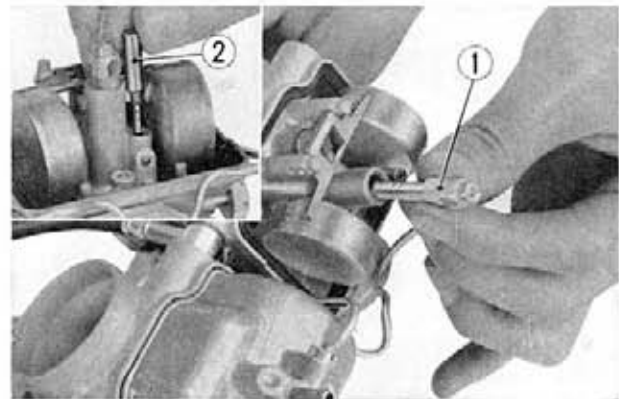


Fig. 6-10 ① Main jet ② Slow jet

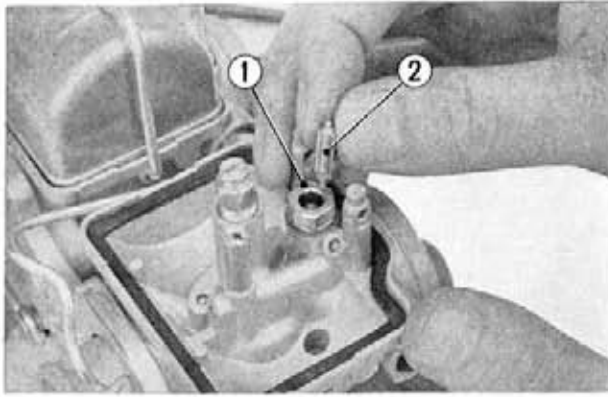


Fig. 6-11 ① Float valve seat ② Float valve

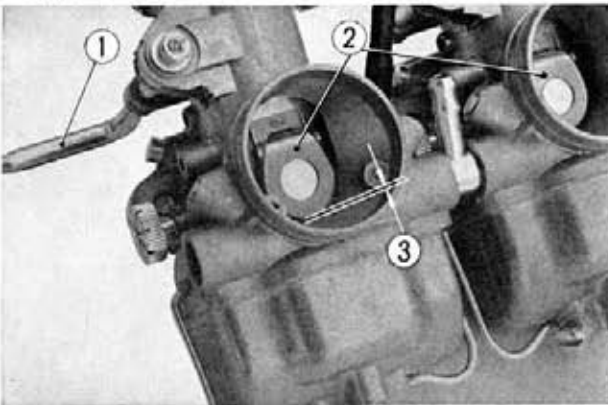


Fig. 6-12 ① Choke lever ② Choke valve
③ Clearance between choke valve and body

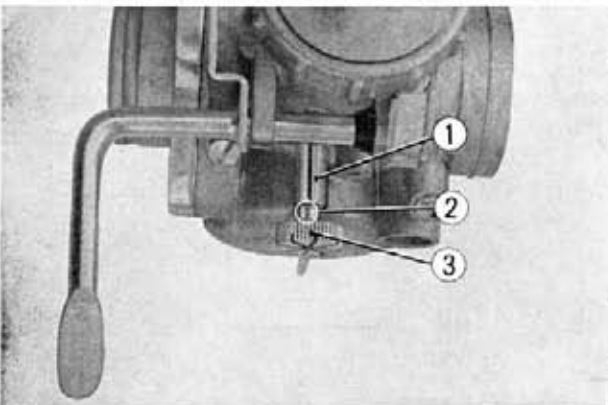


Fig. 6-13 ① Index mark ③ Throttle stop screw
② "T" mark

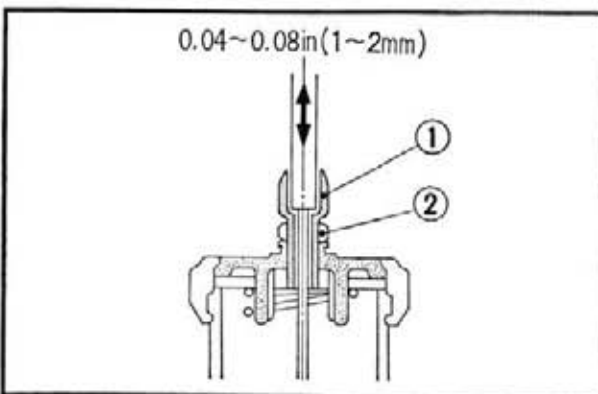


Fig. 6-14 ① Cable adjuster
② Cable adjuster lock nut

2. When either the float valve or valve seat requires replacement, they should be replaced in set. (Fig. 6-11)
3. Install the respective carburetor on the stay plate with two mounting screws and connect the choke rod to the carburetor; make sure that the action of the choke lever is smooth.
4. Install the carburetor assembly on the cylinder head.
5. Assemble the throttle valves and cables on the carburetors and actuate the throttle grip to assure smooth movement of the cable.

6. Carburetor adjustment

Before attempting carburetor adjustment, make sure that the following adjustments have been performed properly.

- a. Contact breaker point gap
- b. Ignition timing
- c. Valve tappet clearance
- d. Spark plug gap
- e. Crankcase oil level

(1) Preliminary adjustment

- a. To make easy of access to the throttle screws on all carburetors, the fuel tank should be removed.
- b. To check the operation of the choke valves remove the air cleaner upper and lower cases. Observe the choke valves from the rear side of the carburetors whether all valves are fully closed or not, when the choke lever is operated.

If there is a clearance greater than **0.02 in. (0.5 mm)** between the choke valve and body, adjust the clearance by lengthening or shortening the choke lever adjusting rod connected to the annex carburetor. (Fig. 6-12)

- c. Adjust the throttle stop screw to align the "T" mark to the index mark stamped on the carburetor body. Perform adjustments on all carburetors. (Fig. 6-13)
- d. Loosen the throttle cable adjuster lock nut and turn the cable adjuster to either directions to obtain the free play of the throttle cable outer within the range of **0.04~0.08 in (1~2 mm)**. After tightening the lock nut check the movement of the outer cable.

The four throttle cables should all be adjusted uniformly. (Fig. 6-14)

- e. Gently turn the air screws in until they seat, then unscrew them one full turn each. (Fig. 6-15)
 - f. Install the air cleaner, air cleaner upper and lower case, fuel tank and fuel lines. Fill gasoline in the fuel tank.
- (2) Final adjustment

For final adjustment use the vacuum gauge. Before attaching the vacuum gauge start the engine and warm up to operating temperature of 140~175°F (60~80°C).

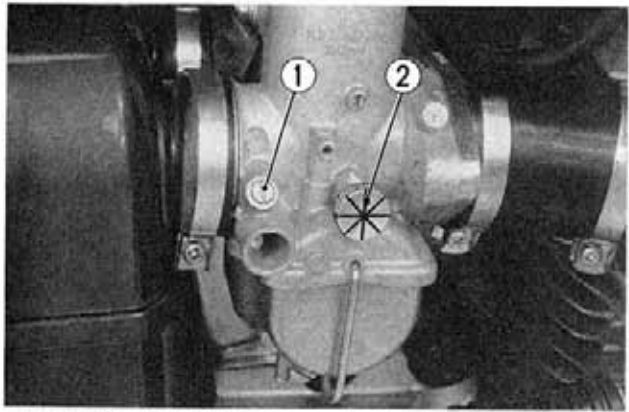


Fig. 6-15 ① Air screw
② Throttle stop screw

- a. Stop the engine and remove the plug of adapter attachment hole on each carburetor bodies. Attach the adapters of vacuum gauge to all carburetors: the long adapters (A) are for inside carburetors and the short ones for outside carburetors. Fit the vacuum gauge hose securely on the adapters. (Fig. 6-16, 17)

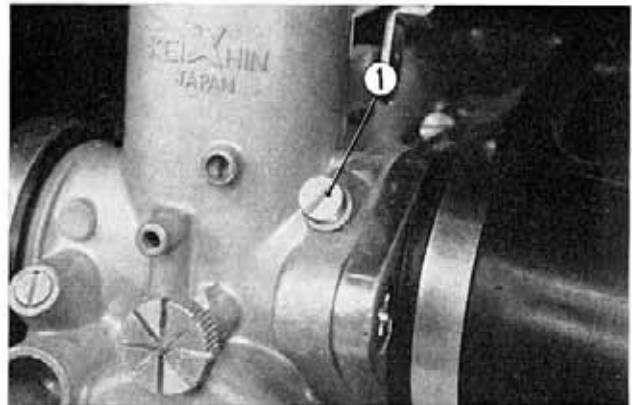


Fig. 6-16 ① plug

- b. Start the engine and run it at the idling speed. Check RPM on the tachometer and if the RPM is not in the range of 850~950RPM adjust all throttle valve stop screws uniformly to obtain the proper speed.

Adjustment should be done within the range of 1/8 turn in both directions while checking the vacuum gauge.

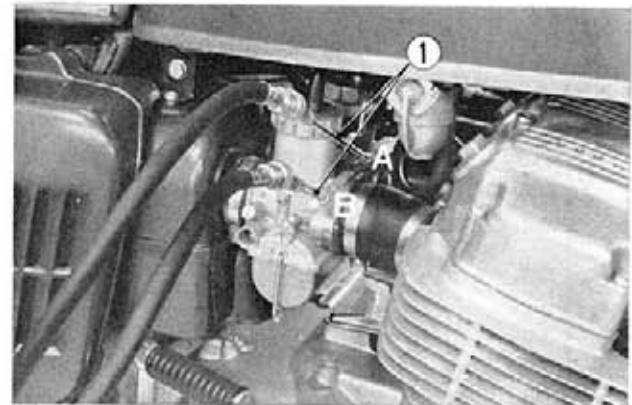


Fig. 6-17 ① Vacuum gauge adapter

- c. The standard vacuum pressure reading should be 20~22cmHG. in all four gauges. If any of these gauges indicates pressure higher or lower than the standard range adjust it with the throttle stop screw. Turning the stop screw clockwise will reduce the pressure and turning it counter-clockwise will bring the pressure higher. (Fig. 6-18)

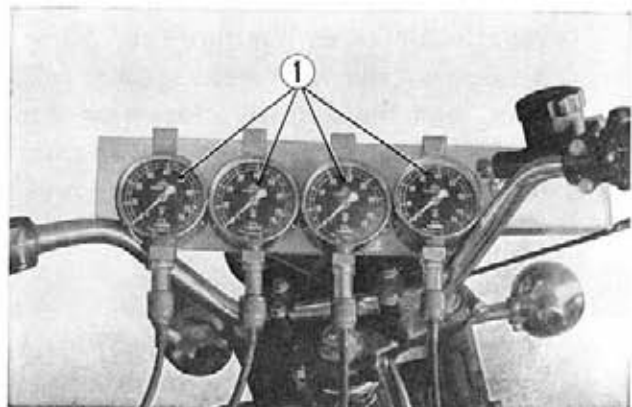


Fig. 6-18 ① Vacuum gauge

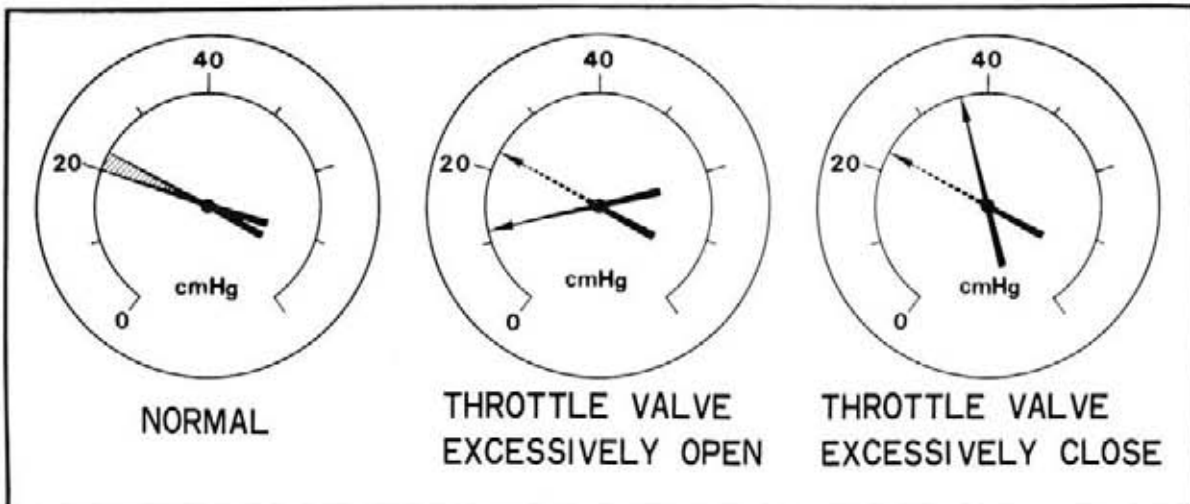


Fig. 6-19

- d. If the swing of the gauge needle is large tighten the gauge restrictor valve to reduce the needle movement within 2 cmHG.

When the indicated pressure is lower than 15 cmHg, check the following possible defects.

- Inlet or exhaust valve sticking open
- Absence of slack in the throttle cable
- Loose spark plug
- Loose clamp on the carburetor connecting tube

- e. Turn the air screw slightly at a time within 1/8 turn in both directions from the original setting, pausing for about 5 seconds to locate a point of highest engine speed by the tachometer. Perform this adjustment to all carburetors.

If it takes over a full turn more or 1/2 turn less than the original setting to change the engine speed check the following possible cause.

| | |
|--|--|
| Air screw adjustment requires over 2 turns | Air screw adjustment requires less than 1/2 turn |
| Clogged air passage | Clogged slow jet |
| Worn air screw valve | Clogged slow jet passage |
| Float level too high | Float level too low |
| Loosened slow jet | Excessively worn air screw valve seat |

- f. Open the throttle valve slowly about 1/4 turn by the throttle grip for 30 seconds. Observe the vacuum gauge and note the location where the drop of pressure is not even to the other carburetors. Slow down the engine and adjust the throttle cable adjuster on the carburetor concerned. If drop of vacuum pressure is quicker than others turn the adjuster clockwise, namely increase the free play of the throttle cable. If the drop of pressure is slower than the others, turn the adjuster counter clockwise. The difference of the vacuum pressure the four carburetors should be less than 2 cmHG. Tighten the lock nuts and fit the rubber caps, when the adjustment has been completed.
- (3) Final adjustment without vacuum gauge
- a. Set the idling speed to 850~950 RPM with the throttle stop screws. Turn the throttle stop screws clockwise to increase the idling speed. Adjust each carburetor in the same amount.



- b. Observe the tachometer and listen to the exhaust noise and/or place a hand at the exhaust outlet to check the exhaust pressure.

Turning out or in very slowly the air screw, obtain the highest engine idle speed or the highest exhaust pressure.

Repeat the same method on all carburetors. The adjustment should not be done exceeding 1/8 turn in both directions.

If there is no change in the engine condition even the adjustment exceeds 1/2 turn in both directions, check possible cause of the defects according to the items in section (2) e.

Adjust the idling speed again by the throttle stop screws to set back to the standard RPM.

- c. Slowly twist the throttle grip 1/4 turn to open the throttle valve and allow seconds to run.

Listen to the exhaust noise and if the noise for four cylinders are not identical and random difference as the throttle opened, an adjustments is necessary. Place a hand at the exhaust outlet and check the exhaust pressure of all four cylinders. Locate one or two carburetors of which the exhaust pressures are different from the others.

Adjust them with the throttle cable adjusters. Turning the adjuster clockwise will increase the throttle cable end play and reduce the exhaust pressure. Turn the adjuster counterclockwise to increase the pressure. After completing the adjustment, tighten the adjuster lock nut and properly install the rubber seal cap.

- (4) Other inspections.

- Snap the throttle grip several times and then recheck the vacuum pressure readings or exhaust noise to assure that they are all the same.
- Turn the steering all the way to the right and left side and snap the throttle grip few times to check that the carburetors are operated smoothly.
- The air vent tube must be positioned over the air cleaner case.
- The adjustments of the throttle grip free play and the grip damping force should be referred to the group 19 (page 182)

6-3 FUEL TANK AND VALVE

a. Description

The fuel tank is mounted on the frame body directly above the engine and is installed on the frame body through the fuel tank rubber cushions. (Fig. 6-20)

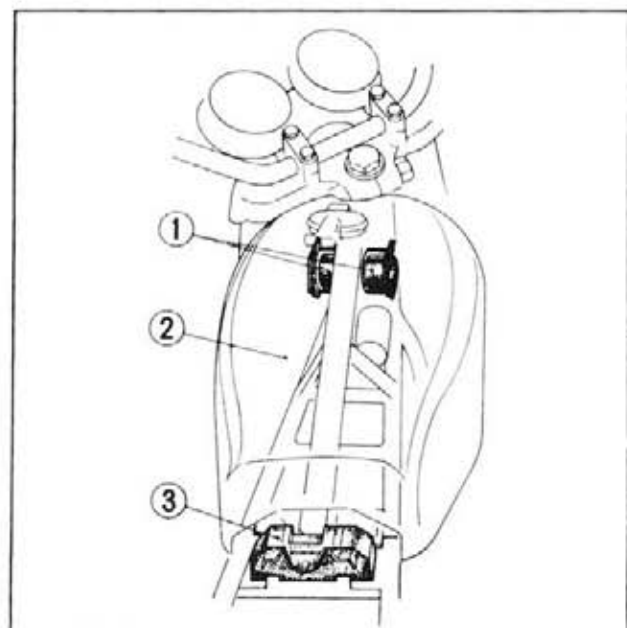


Fig. 6-20 ① Fuel tank front cushions
② Fuel tank
③ Fuel tank rear cushion

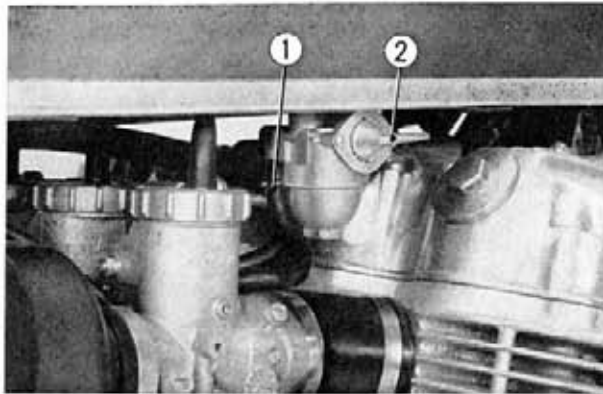


Fig. 6-21 ① Fuel tube ② Fuel valve

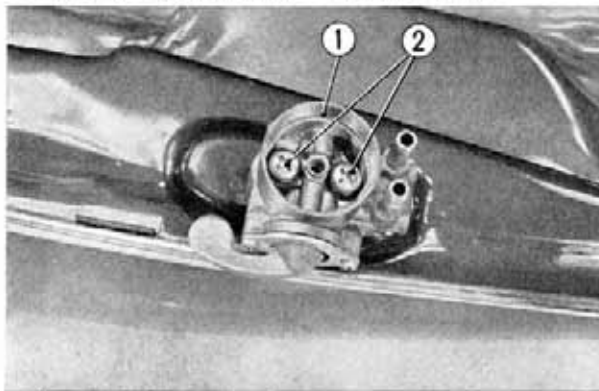


Fig. 6-22 ① Fuel valve
② Fuel valve mounting screws

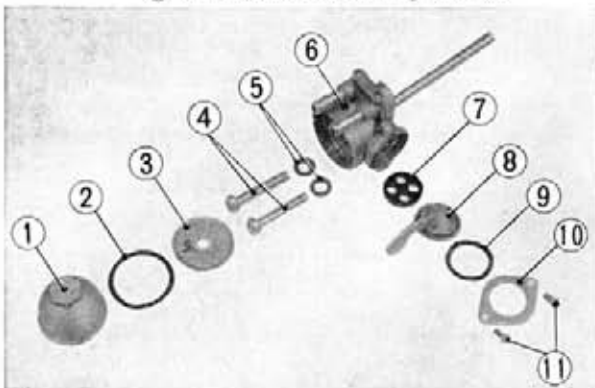


Fig. 6-23 ① Fuel strainer cup ② O ring ③ Fuel strainer screen ④ 6mm cross screws ⑤ Fuel cock fixing packing ⑥ Fuel valve body ⑦ Fuel cock valve packing ⑧ Fuel cock lever ⑨ Cock lever spring ⑩ Setting plate ⑪ Cross screws

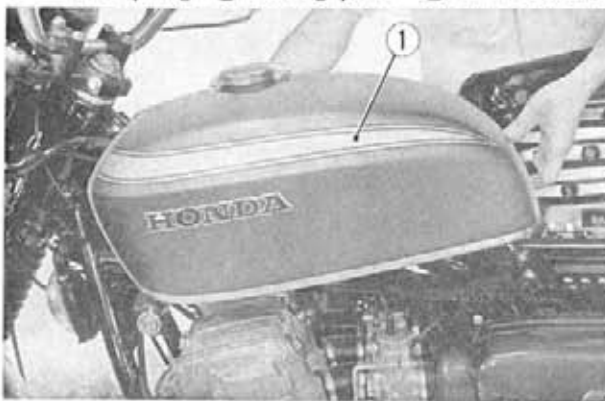


Fig. 6-24 Fuel tank

b. Disassembly

1. Switch the fuel valve to "STOP" and disconnect the fuel tube from the fuel valve. (Fig. 6-21)
2. Raise the seat, open the fuel tank rear cushion and remove the fuel tank to the rear and raise.
3. Remove the fuel strainer cap, O ring and fuel strainer screen.
4. Remove the two fuel valve mounting screws and remove the fuel valve from the tank. (Fig. 6-22)

c. Inspection

1. Inspect the fuel for leaks.
2. Inspect for clogging of the filler cap vent hole.
3. Inspect the front and rear cushion rubbers for deterioration, wear and other damages.
4. Inspect for damage to the valve cock packing and the filter screen, and then clean them with gasoline. (Fig. 6-23)
5. Inspect the fuel tube for defects.

d. Reassembly

1. Install the fuel cock assembly on the tank with two screws.
2. Fit the front and rear rubber cushions to the frame body. The front rubber cushions should be inserted by pushing the fuel tank from the rear. (Fig. 6-24)

Install the fuel tank rear bracket on the rear cushion.

Note: When installing the tank, particular attention should be give to the condition of the wires and their routing.

3. Install the fuel lines using fuel tube clips and connect the fuel tubes to the tank valve.
4. Turn the fuel valve cock to the "ON" position and check the fuel for leaks.

IGNITION SYSTEM

GROUP

7

CONTENTS

| | |
|--|----|
| 7-1 GENERAL DESCRIPTION | 84 |
| DESCRIPTION | 84 |
| SPECIFICATIONS | 84 |
| IGNITION TIMING TEST | 85 |
| 7-2 IGNITION COIL | 86 |
| a. Description | 86 |
| b. Disassembly | 86 |
| c. Inspection | 86 |
| d. Reassembly | 87 |
| 7-3 SPARK PLUG | 87 |
| a. Description | 87 |
| b. Disassembly | 88 |
| c. Inspection | 88 |
| d. Reassembly | 89 |
| 7-4 CONTACT BREAKER AND CONDENSER | 89 |
| a. Description | 89 |
| b. Disassembly | 90 |
| c. Inspection | 90 |
| d. Reassembly | 90 |
| 7-5 SPARK ADVANCER | 92 |
| a. Description | 92 |
| b. Disassembly | 92 |
| c. Inspection | 92 |
| d. Reassembly | 92 |

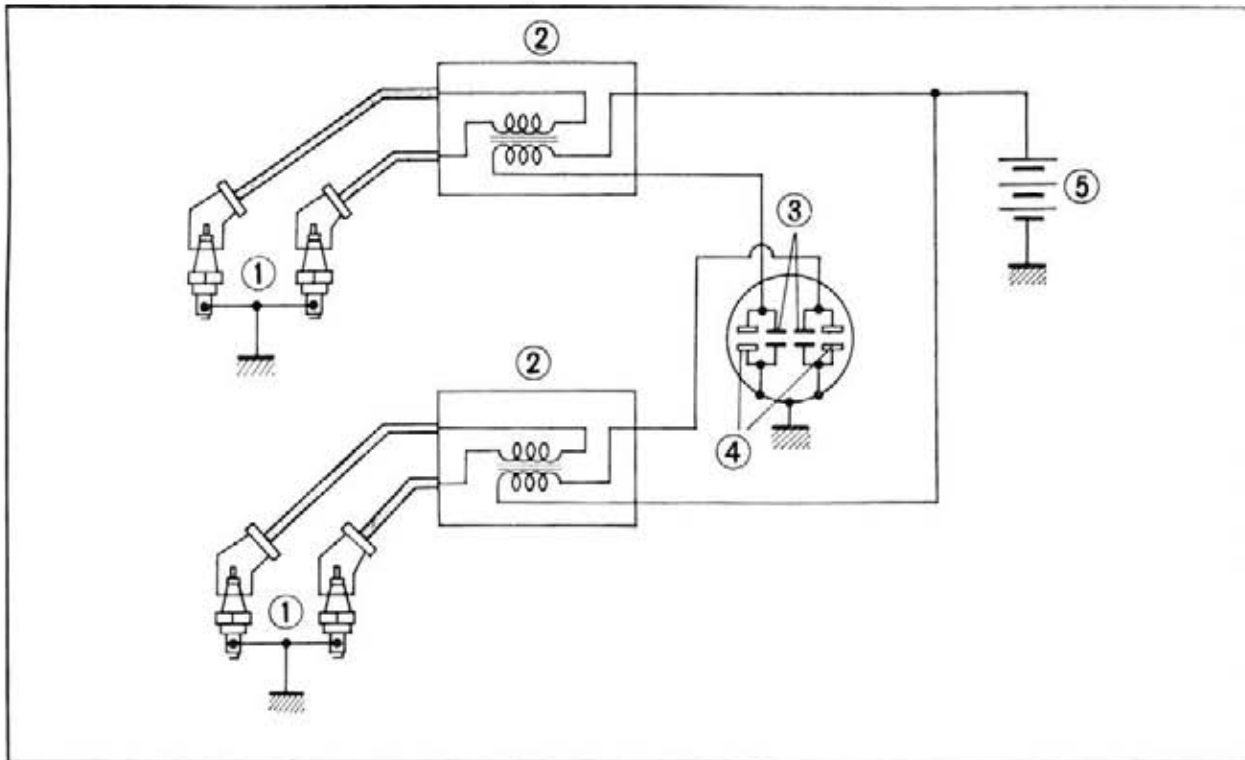
7-1 GENERAL DESCRIPTION

DESCRIPTION

The ignition system consists of two ignition coils, two contact breakers, four spark plugs, an ignition switch and a battery.

The current from the battery flows through the primary winding of the ignition coil and circuit is completed by grounding through the contact breaker. There are two contact breakers which are located 180° apart.

One of the breakers furnishes the high voltage currents to spark plugs 1 and 4; the other breaker furnishes the current to plugs 2 and 3. The contact breakers ignites the spark plugs in alternate sequence to provide a firing sequence of 1, 2, 4 and 3. Since no distributor is used, the construction is simple and the system is easy to service. (Fig. 7-1)



① Spark plugs
② Ignition coil

③ Contact breaker
④ Condenser

⑤ Battery

Fig. 7-1

SPECIFICATIONS

| | |
|--------------------------------------|--|
| Ignition coil make | Toyo Denso |
| Spark plug type | |
| Standard | NGK D-8 ES |
| Optional | NGK D-7 ES, D-10E |
| Size | 12 mm (thread diameter), 12.7 mm (reach) |
| Gap | 0.024~0.028 in (0.6~0.7 mm) |
| Contact breaker make | Hitachi |
| Spring force | 1.43~1.87 lb (650~850 g) |
| Point gap | 0.012~0.016 in (0.3~0.4 mm) |
| Condenser capacity | 0.24 μ F \pm 10% |
| Condenser insulator resistance | Over 10 M Ω (1,000 meger) |
| Spark advancer | |
| Crankshaft speed at start of advance | 1,000~1,150 rpm |
| Crankshaft speed at full advance | 2,300~2,500 rpm |
| Advance angle | 35° |



DIAGNOSIS

| Item | Probable Causes | Remedy |
|---|---|---|
| Engine over heat | 1. Ignition timing out of adjustment | Adjust ignition timing |
| Spark plug does not fire | 1. Defective ignition coil 2. Defective spark plug | Replace Replace |
| Spark at points excessive Weak spark No spark | 1. Defective condenser 2. Broken or shorted ignition high tension cord 3. Dirty spark plug electrodes | Replace Replace Clean spark plug electrodes |

IGNITION TIMING TEST

An accurate timing test can be made by using a strobo timing light.

Follow the procedure below for checking timing with the service tester. (Tool. No. 07308-0010000)

1. Connect the power cord to the battery and ground the black ground cable. (Fig. 7-2)
2. Set the selector knob to TIMING.
3. Plug in the timing light cable and attach the high voltage cord to the No. 1 (or No. 4) spark plug head attachment.
4. Remove the point cover on the right side of the crankcase.
5. Start the engine and with the engine idling (850~950 rpm), point the strobo timing mark.

The ignition timing is correct, if the F mark (1.4 cylinder) on the spark advancer is aligned to the timing mark. (Fig. 7-3)

6. Next, raise the engine speed above 2,500 rpm : if the timing index mark is between the two timing marks located at 23.5~26.5° ahead of the "F" mark, the timing for both idling and full advance is satisfactory.

If there is malfunction with the ignition timing even though the RPM is constant, the fault is probably with the spark advancer spring or a defect in the breaker points, therefore, the unsatisfactory parts should be repaired or replaced.

If it is necessary to make adjustment, perform the adjustment in accordance with the procedure described in service adjustment on page 91~92.

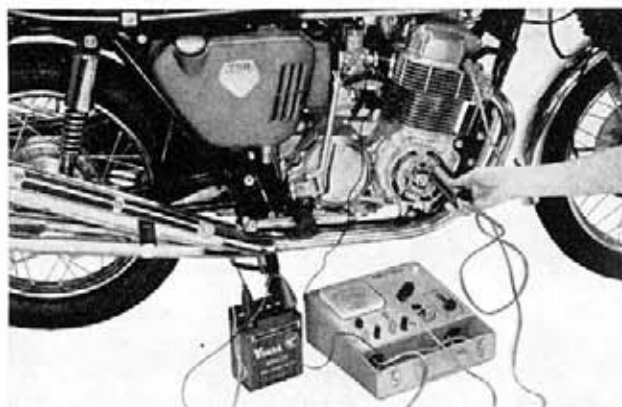


Fig. 7-2

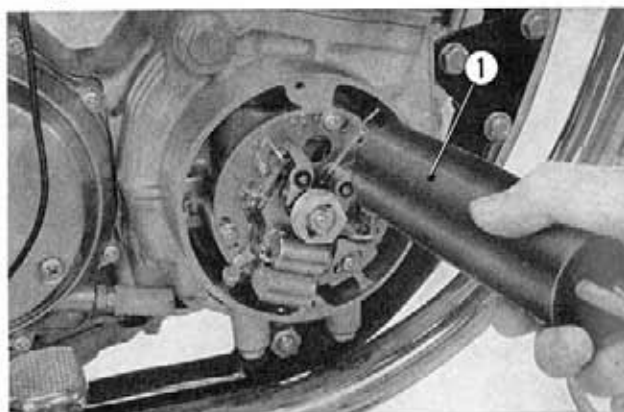


Fig. 7-3 Timing light

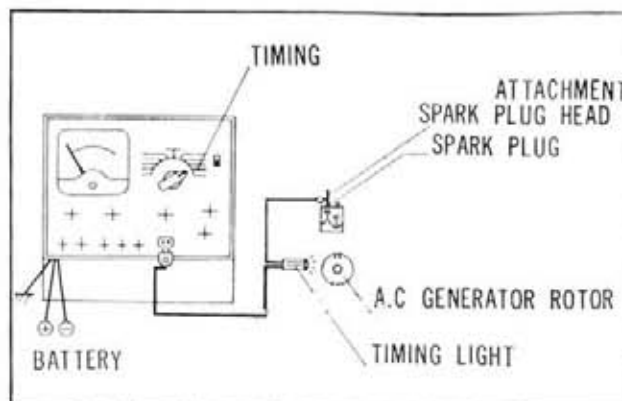


Fig. 7-4 Ignition timing test

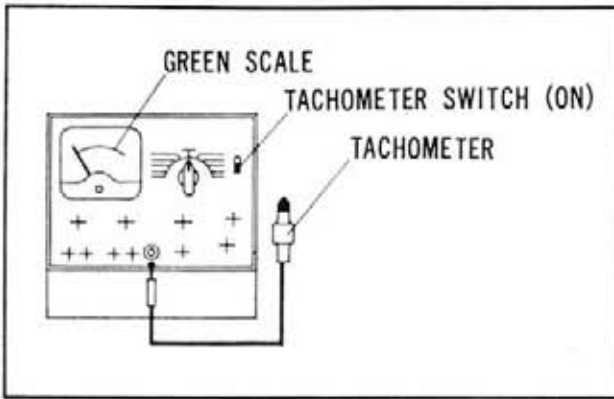


Fig. 7-5

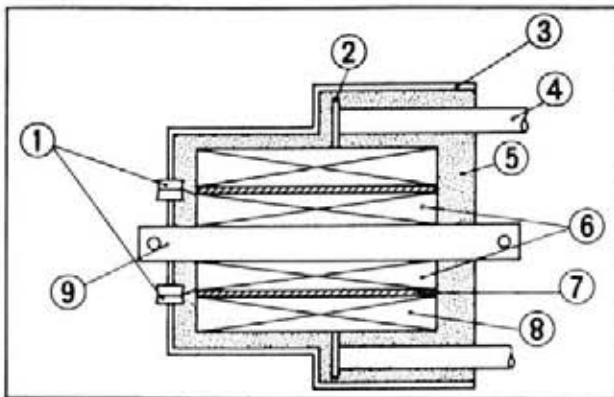


Fig. 7-6 ① Primary terminal ⑤ Synthetic resin
② High tension terminal ⑥ Primary coil
③ Case ⑦ Bobbin
④ High tension cord ⑧ Secondary coil
⑨ Iron core

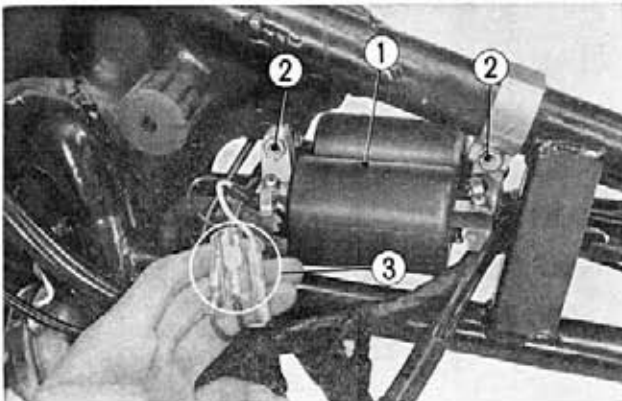


Fig. 7-7 ① Ignition coil ③ Leads connectors
② Mounting bolts

Connect the ignition primary cord plug to the tester and connect the opposite terminal end to the primary terminal of the coil. Connect red test lead to the black terminal of the ignition coil; the white lead to the yellow cord of the left coil (right coil to the blue cord).

Connect the high tension cable (red) to the secondary coil terminal.

Position the selector knob to COIL TEST. Adjust the three point spark tester to the maximum distance spark is maintained and then note this distance. The coil is satisfactory if the distance is greater than **0.28 in (7 mm)**.

7. The ignition timing for the No. 2 and 3 cylinders are also checked in the same manner described above.

8. The engine RPM is checked with a tachometer or a revolution counter located on the tester. Set the tachometer switch to the ON position, insert the tachometer cable, place the tachometer against the center of the spark advancer shaft and then read off the green scale.

7-2 IGNITION COIL

a. Description

The ignition coil of a primary coil with 380 turns of enameled and secondary coil with 15,000 turns wire wound around the primary coil, with an iron core of laminated silicon steel sheets in the center. Each secondary coil has two high tension cables that lead to two spark plugs. (Fig. 7-6)

b. Disassembly

1. Open the seat and remove the fuel tank in accordance with section 6-3 b on page 74.
2. Disconnect the electrical leads (yellow, blue and black/white leads).
3. Unscrew the two ignition coil mounting bolts and then the ignition coil can be removed from the frame. (Fig. 7-7)

c. Inspection

1. Bench testing ignition coil
Check the ignition coil using the service tester by following the procedure below. (Fig. 7-8,9)

Connect the power cord to the 12V battery and ground the black ground cord.



Note :

Spark condition as shown in Fig. 7-9A is normal. Fig. 7-9B shown the spark condition when the test leads are connected in reverse at the ignition coil.



Fig. 7-8 Ignition coil test

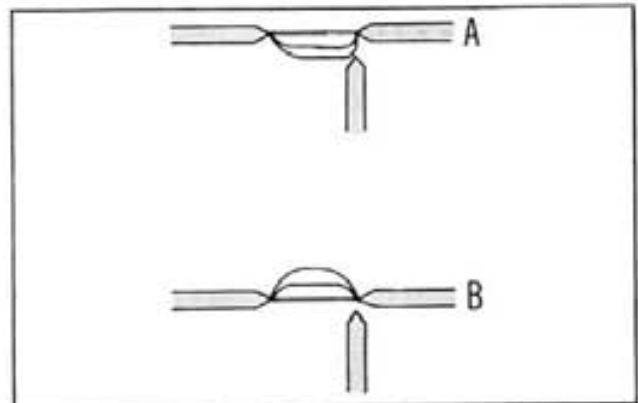


Fig. 7-9

2. Testing the coil without removing

External battery is not required. Connect the tester ground lead (black) to the motor-cycle frame. Remove the spark plug cap and install the spark plug head attachment on the spark plug. Connect high voltage tester cable to the attachment and then reinstall the spark plug cap.

Turn the ignition switch to the ON position use the kick starter or starting motor to turn over the engine and determine the maximum sparking distance of the coil.

3. Check the high tension cord for damage and deterioration, if it is found to be improper condition, replace it with new one.

d. Reassembly

1. Mount the ignition coil assembly on the frame with the two bolts.
2. Connect electrical leads (yellow, blue and black/white leads) to wire harness leads.
3. Install the fuel tank carefully not to damage the electrical leads or cables.

7-3 SPARK PLUG

a. Description

The main parts of the spark plug are the electrodes, insulator and the plug body.

Standard spark plug used is NGK D-8ES.

However, the following types are also available for different operating condition (Fig.7-10)

| | |
|-------------|--------|
| Hotter type | D-7 ES |
| Standard | D-8 ES |
| Colder type | D-10 E |

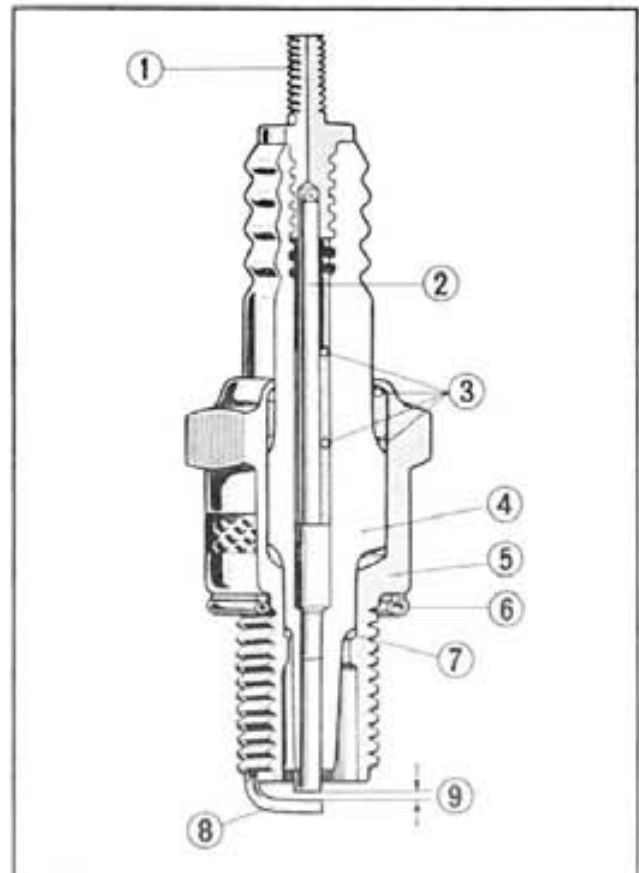





Fig. 7-10 ① Terminal ⑥ Gasket
② Center electrode ⑦ Lower sealing
③ Wire packing ⑧ Ground electrode
④ Insulator ⑨ Spark gap
⑤ Shell

b. Disassembly

1. Remove any foreign matter from around the spark plugs by blowing out with compressed air.
2. Detach the high tension cord cap and remove the spark plug with the special wrench provided in the tool kit.

c. Inspection

1. Inspect each spark plug for badly worn electrodes, broken or cracked porcelain insulator. The spark plug conditions and corrective action procedure is shown below.

| Spark plug condition | Cause | Corrective action |
|---|--|---|
| Electrode coated with carbon deposit  | <ol style="list-style-type: none"> 1. Too rich a fuel 2. Excessive idling 3. Poor quality gasoline 4. Clogged air cleaner 5. Use of cold spark plug | Adjust carburetor Adjust idling Use good quality gasoline Service the air cleaner Use proper heat range plug (hot type) |
| Electrode fouled with oil  | <ol style="list-style-type: none"> 1. Worn piston ring 2. Worn piston and cylinder 3. Excessive clearance between valve guide and valve stem | Replace piston ring Replace piston or cylinder Replace valve guide or valve |
| Electrode overheated or burnt  | <ol style="list-style-type: none"> 1. Use of hot spark plug 2. Engine over heating 3. Improper ignition timing 4. Loose spark plug or damaged spark plug hole thread 5. Too lean a fuel mixture | Use proper heat range plug Readjust ignition timing Retighten plug or replace cylinder head Adjust carburetor |
| Damage | Spark plug over torqued | Replace with a new spark plug |

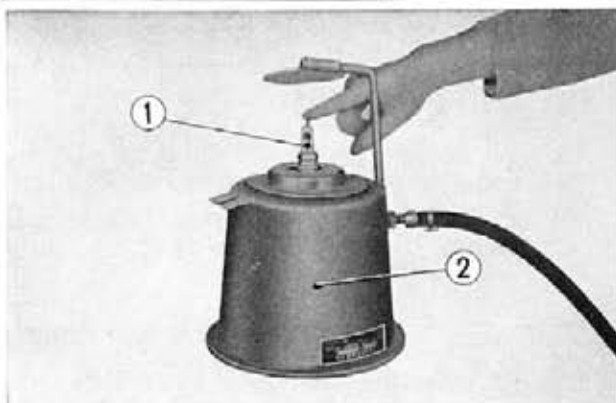


Fig. 7-11 ① Spark plug
② Spark plug cleaner

2. Plug cleaning is best performed by spark plug cleaning set, however, lacking this set, a satisfactory job can be performed by using a wire brush or stiff pin to remove the deposits and washing in gasoline. (Fig. 7-11)

3. After completing inspection of section 2 adjust spark plug gap to 0.024~0.028 in (0.6~0.7 mm). The gap can be measured by a thickness gauge. The adjustment is made by bending the negative (ground) electrode (Fig. 7-12)
4. Inspect the spark plug hole threads and clean before installing plugs. Corrosion deposits can be removed with a 12 mm × 1.25 mm pitch thread tap or by using a small wire brush.

Note :

1. Never use an improper heat range spark plug.
2. Do not attempt to dry or remove soot from the spark plug by burning.

d. Reassembly

1. Install the spark plug in the reverse order of disassembly.

Note :

1. The spark plugs in the No. 2 and No. 3 cylinders are difficult to reach and if care is not taken during the removal and installation of these spark plugs, it is possible for the plugs to be dropped and become lodged in the cylinder head cavities. (Fig. 7-13)
2. All spark plugs must be properly torqued. Loose plug will not properly dissipate heat and become very hot, causing possibly damage to the engine.

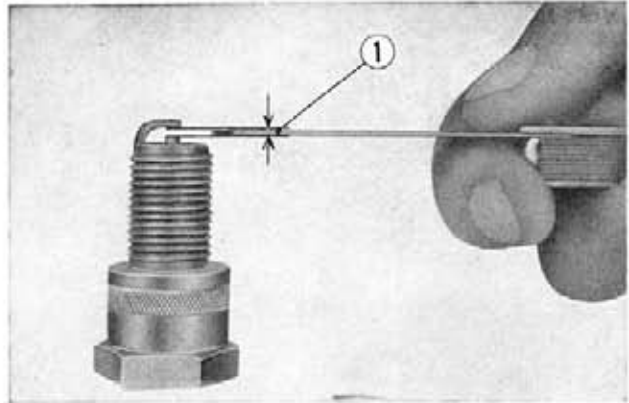


Fig. 7-12 ① Spark plug gap

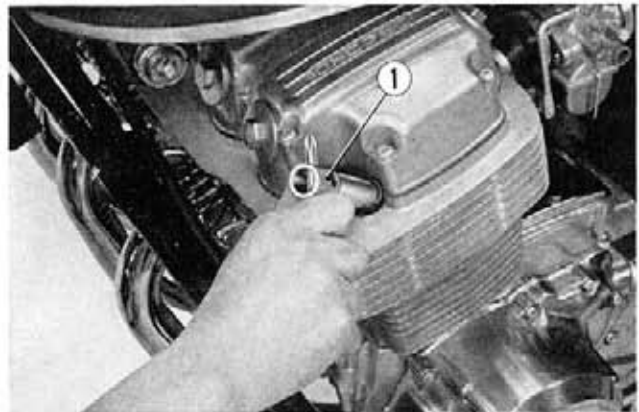


Fig. 7-13 ① Spark plug wrench

7-4 CONTACT BREAKER AND CONDENSER

a. Description

The contact breaker is mounted in the compartment which is at the right end of the crankshaft and consists of a base plate, two breaker arms, fixed and movable points, primary terminal, spring and lubricating felt.

The two condensers are also located on the contact breaker base.

The purpose of the condenser is to prevent unwanted sparking across the points. (Fig. 7-14)

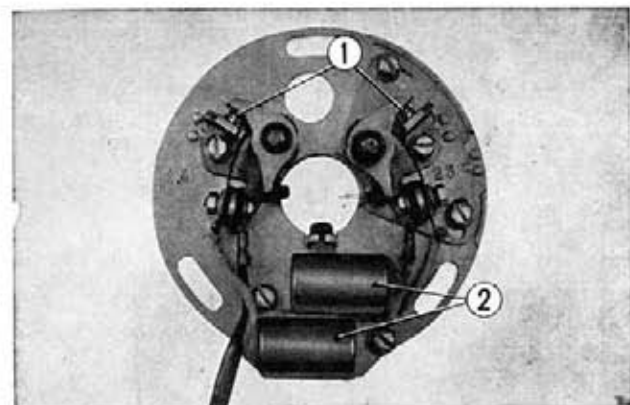


Fig. 7-14 ① Contact breaker
② Condenser

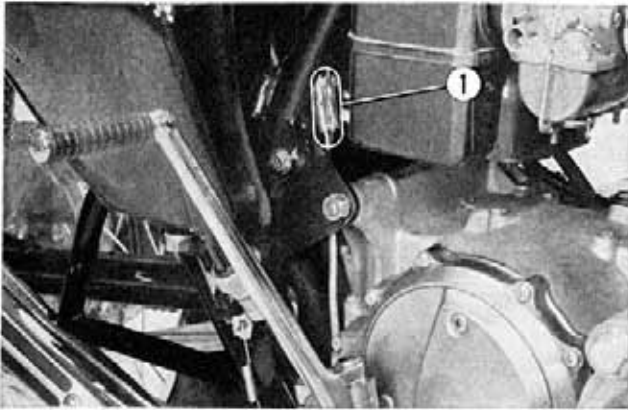


Fig. 7-15 ① Contact breaker lead

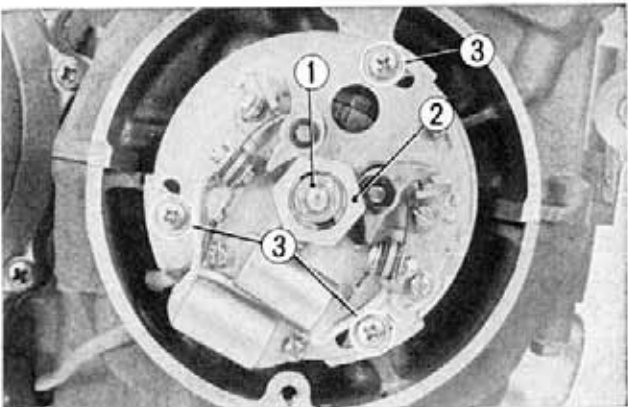


Fig. 7-16 ① 6 mm hex nut
② Special washer
③ Contact breaker setting screws

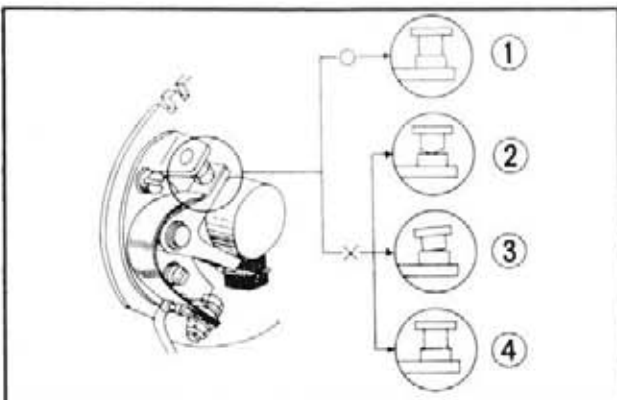


Fig. 7-17 ① Correct
② Contact is worn
③ One side contact
④ Contamination of the contact

b. Disassembly

1. Remove the point cover.
2. Disconnect the lead connectors (yellow and blue leads) at the center of the frame, right lower side. (Fig. 7-15)
3. Unscrew the 6 mm hex nut and remove the contact breaker assembly. (Fig. 7-16)
4. The condenser can be removed from the breaker base.

c. Inspection

1. Checking the contact breaker point.

If oil is left for a long time without removal, a hard film will be formed and eventually result in misfiring.

Therefore, remove oil with trichloroethylene from the contact breaker point.

 - a. Dress the pitted or dirty point with either a point file or emery paper, however, if the condition is relatively severe, remove the contact breaker arm and dress the points on both the arm and the stationary point with an oil stone, making sure that the points will have parallel contact when assembled. The point gap should be adjusted to **0.012~0.016 in (0.3~0.4 mm)**. (Fig. 7-17)
 - b. Replace the breaker arm if the pivot hole worn excessively.
 - c. Always maintain the contact breaker terminal and insulators as well as the wiring free from water, oil, and foreign matters.
 - d. After the points have been dressed, clean the surfaces with a clean rag soaked in small amount of trichloroethylene, further, oil or other foreign matters should not be permitted on the breaker assembly.
3. Condenser capacity

Measure the condenser capacity with the service tester. If the capacity is **0.22~0.26 μF** , it is satisfactory. Refer to the service tester operating instruction leaflet for the measuring procedure.

d. Reassembly

1. Assemble the each component parts on the contact breaker base plate.
2. Install the contact breaker assembly with the three setting screws.

3. Install the advancer shaft special washer, 6 mm washer and tighten 6 mm hex nut. (Fig. 7-18)
4. Connect the electrical leads.
5. When attempting the ignition timing adjustment, both the ignition timing and the breaker points gap should be adjusted.

(1) Contact breaker point gap (Fig. 7-19)

Before adjusting ignition timing the breaker points must be checked.

Open the spring loaded contact breaker point by a finger and check surface condition.

If the points are erroded, pitted or burnt, dress with a point file and follow by polishing with unwaxed paper to remove any file dust.

Next, turn the crankshaft in the clockwise direction hold at the position where the point gap is at maximum opening and check the gap by inserting a filler gauge. The standard gap is between 0.012 to 0.016 in (0.3~0.4 mm).

To adjust the point gap, loosen the contact breaker plate locking screw and move the contact breaker to the right or left until the proper gap opening is obtained and then tighten the locking screw. (Fig. 7-19)

(2) Ignition timing adjustment

After testing the ignition timing with the service tester, it is found to adjust the ignition timing, perform the following manner.

- a. Start adjustment from the 1.4 breaker point indicated on the base plate.
- b. Remove the contact breaker wire terminal unscrewing the retaining nut and connect one end of continuity light to the point terminal and hook the negative terminal to the crankcase.

Rotate the crankshaft in the clockwise direction slowly to align the "F" (1.4 cylinder) timing mark to the index mark. At this moment the breaker point should just to open while the continuity light flickers or goes off.

If point opening moment is incorrect, adjustment should be made in the following manner.

- c. Loosen the three base plate setting screws ② (Fig. 7-20) and carefully rotate the base plate until the continuity light flickers. Tighten base plate setting screws. Rotating the base

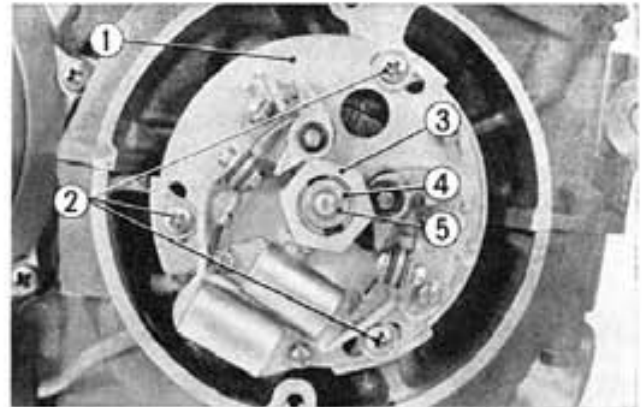


Fig. 7-18 ① Contact breaker assembly
② Contact breaker setting screws
③ Advancer shaft special washer
④ 6 mm washer ⑤ 6 mm hex nut

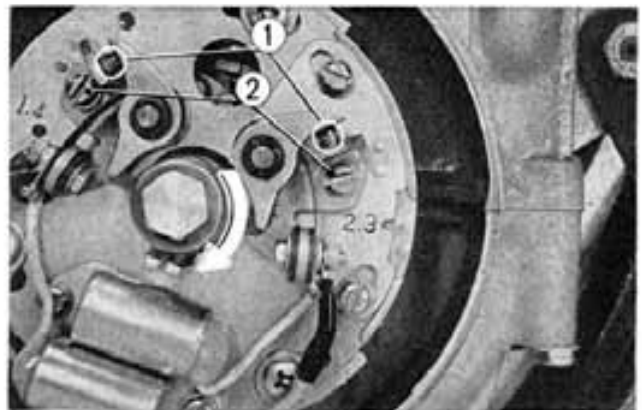


Fig. 7-19 ① Contact breaker points
② Contact breaker plate locking screw

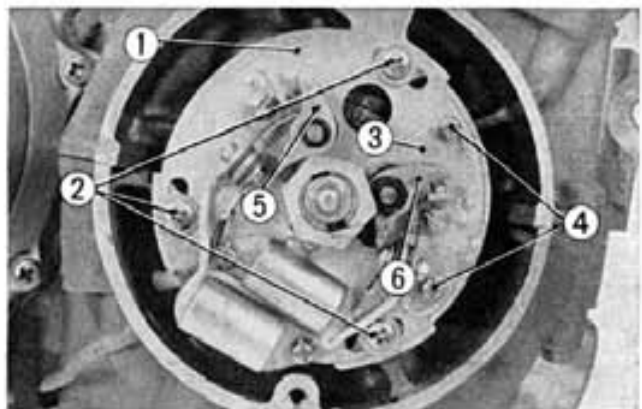


Fig. 7-20 ① Contact breaker base plate
② Base plate setting screws
③ Right base plate
④ Right base plate setting screws
⑤ 1.4 cylinder breaker points
⑥ 2.3 cylinder breaker points

plate clockwise will retard ignition timing, counterclockwise rotation will advance ignition timing.

- d. Next connect continuity light to 2.3 cylinder breaker points. Rotate the crankshaft 180° in the clockwise direction and align the "F" (2.3 cylinder) timing mark to the timing index mark.

Adjustment may be done in the same manner as mentioned in section a and b by loosening two base plate locking screws ④.

- e. Recheck the contact breaker points gaps and recheck the ignition timing with service tester on page 85~86.

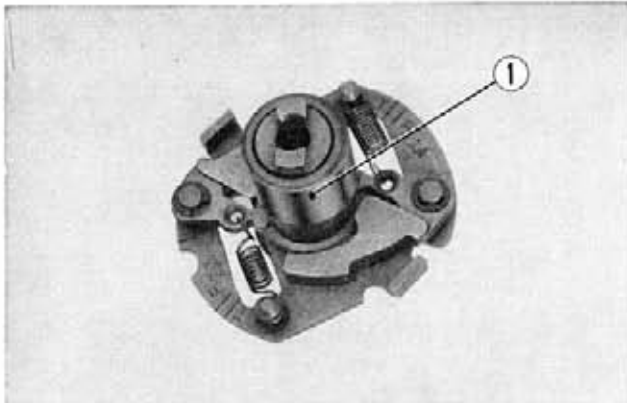


Fig. 7-21 ① Spark advancer

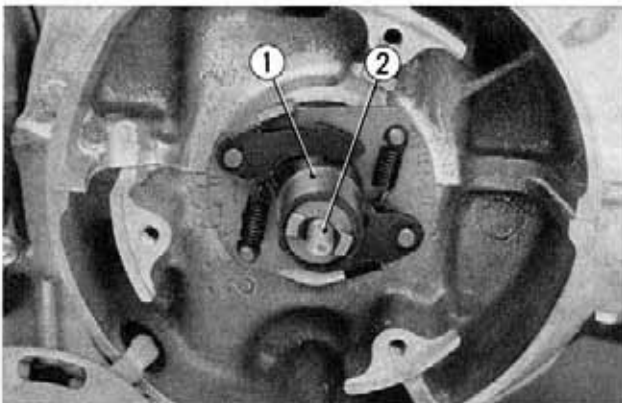


Fig. 7-22 ① Spark advancer
② Spark advancer shaft

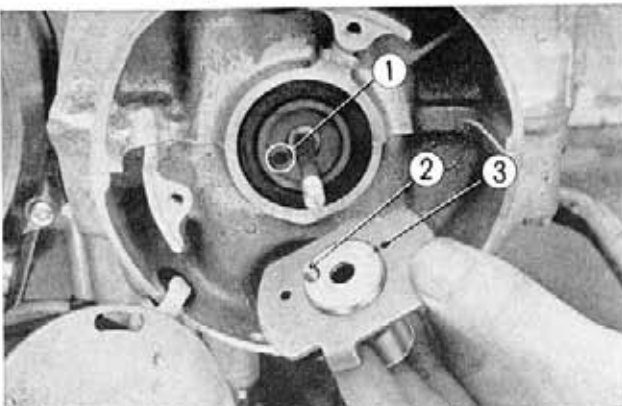


Fig. 7-23 ① Pin hole
② Spark advancer pin
③ Spark advancer

7-5 SPARK ADVANCER

a. Description

Centrifugal advance type mechanism is used to advance the spark.

As the speed of the engine increases, the centrifugal force of the advancer weight overrides the force of the spring and starts to move outward, moving the point cam in the direction of rotation, in other words, advances the point cam to produce an early ignition.

The advancer assembly is mounted on the crankshaft inboard of the contact breaker point assembly. (Fig. 7-21)

b. Disassembly

1. Remove the contact breaker in accordance with section 7-4. b on page 90.
2. Remove the spark advancer from the spark advancer shaft. (Fig. 7-22)

c. Inspection

Check the spark advancer spring for loss of tension and also the advancer pin for excessive wear; replace any part found worn excessively or defective.

d. Reassembly

1. Install the spark advancer to make sure that the pin is inserted into the pin hole at the end of the crankshaft. (Fig. 7-23)
2. Install the contact breaker assembly in the reverse procedure of disassembly.

CHARGING SYSTEM

GROUP

8

CONTENTS

| | |
|--------------------------------------|-----|
| 8-1 GENERAL DESCRIPTION | 93 |
| DESCRIPTION | 93 |
| SPECIFICATIONS | 96 |
| DIAGNOSIS | 97 |
| CHARGING TEST | 98 |
| 8-2 ALTERNATOR | 99 |
| a. Description | 99 |
| b. Disassembly | 99 |
| c. Inspection | 99 |
| d. Reassembly | 100 |
| 8-3 REGULATOR | 100 |
| a. Description | 100 |
| b. Disassembly | 100 |
| c. Inspection | 100 |
| d. Reassembly | 101 |
| 8-4 SILICON RECTIFIER | 101 |
| a. Description | 101 |
| b. Disassembly | 102 |
| c. Inspection | 102 |
| d. Reassembly | 102 |

8-1 GENERAL DESCRIPTION

DESCRIPTION

The charging system for the CB750 is made up of the excited field 3-phase alternator, rectifier, voltage regulator and the fuse. The alternator consists of the battery excited field coil, stator coil and the rotor; it does not, however, contain a slip-ring or brushes.

In order for the stator coil to produce a constant voltage, the current from the battery to produce the exciter field is regulated to very close limits by the dual contact regulator. The output from the alternator is rectified by the silicon rectifier before being sent to re-charge the battery.

The regulator has two different types of function depending upon the charge condition of the battery.



The electrical current from the battery flows through the switch and into the regulator. When the battery voltage is lower than normal (less than 13.5V at the battery terminal), the current flowing through the armature away from the upper contact and the battery to the generator field coil. The strength of the magnetic field is depended upon the strength of the battery voltage. The current field coil is 1.6 A at a battery terminal voltage of 12V. This produces an output voltage of corresponding strength which is used to charge the battery. (Fig. 8-1)

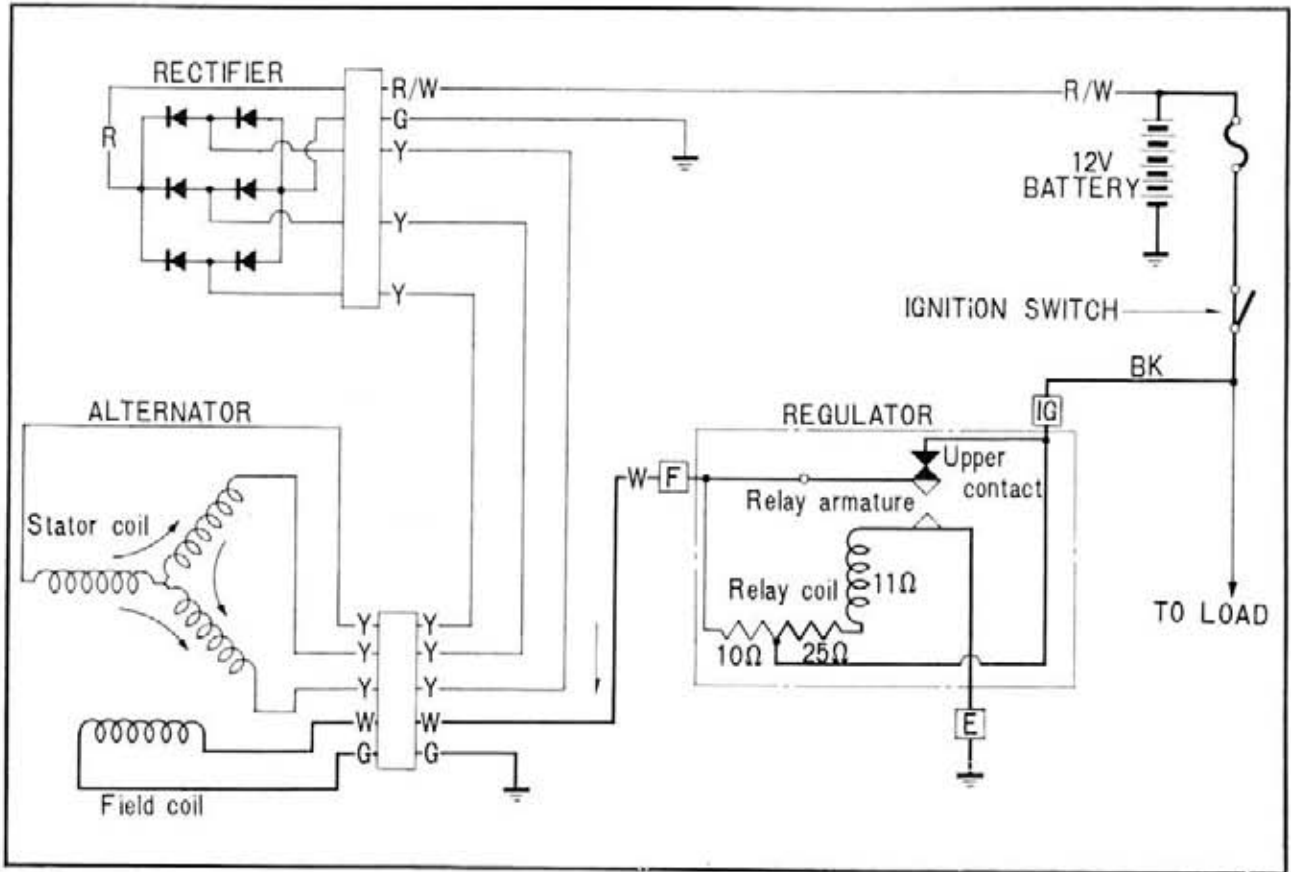


Fig. 8-1

When the battery voltage exceeds approximately 14.5V the armature coil pulls the armature away from the upper contacts and closes the lower contacts to insert a resistance (10Ω resistor) in the generator field coil circuit ; as the result of the resistance, the current to the field coil is reduced to 0.7 A and consequently a lower voltage is produced by the generator, limiting the amount of charge to the battery.

This function of inserting or removing the resistance into the generator field coil is performed by the voltage regulator in accordance with the charge condition of the battery regulate the charging of the battery. (Fig. 8-2)

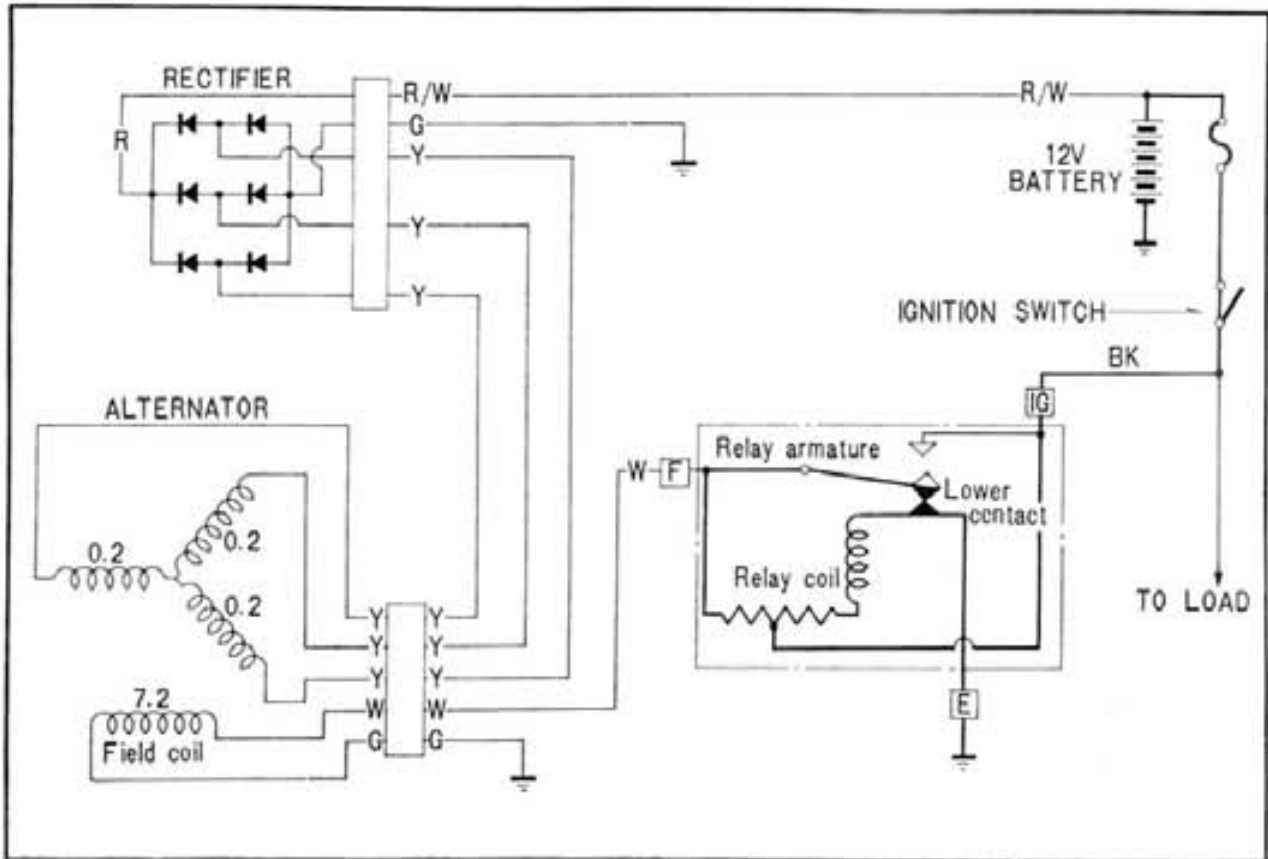


Fig. 8-2



SPECIFICATIONS

| | |
|------------------------|-----------------------------|
| 1. Alternator | |
| Type and make | LD 113-01, Hitachi. |
| Battery voltage | 12 V |
| Output | 12 V 13 A |
| Polarity | (-) ground |
| Weight | 11.0 lbs (5 kg) |
| Stator coil resistance | 0.2 Ω |
| Field coil resistance | 7.2 Ω |
| 2. Regulator | |
| Type and make | TLIZ-38, Hitachi. |
| Battery voltage | 12 V |
| Polarity | (-) ground |
| Weight | 0.49 lb (0.22 kg) |
| Core gap | 0.024~0.04 in (0.6~1.0 mm) |
| Point gap | 0.012~0.016 in (0.3~0.4 mm) |
| 3. Silicon rectifier | |
| Type and make | SB6B-7, Hitachi. |
| Battery voltage | 12 V |
| Output | 12 V 15 A |
| Polarity | (-) ground |
| Weight | 0.99 lb (0.45 kg) |

DIAGNOSIS

| Trouble | Probable Causes | Remedy |
|---------------------------|---|--|
| No charging | <ol style="list-style-type: none"> 1. Broken wire or short, loose connection. 2. Defective coil due to short, grounding, open circuit. 3. Defective silicon diode. 4. Broken or shorted lead wire at regulator. 5. Regulator voltage at no load is too low. | Repair or replace Replace Replace Repair or replace Readjust |
| Insufficient charging | <ol style="list-style-type: none"> 1. Wiring <ul style="list-style-type: none"> • Broken wire, intermittent shorting or loose connection. 2. Generator <ul style="list-style-type: none"> • Shorting across layer in the field coil (resistance indicated in continuity test). • Shorting across layer in stator coil. • Open circuit in one of the stator coil. • Defective silicon diode. 3. Regulator <ul style="list-style-type: none"> • Voltage below specified value at no load. • Dirty or pitted points. • Coil or resistor internally shorted. 4. Battery <ul style="list-style-type: none"> • Low electrolyte level. • Defective battery plates. | Repair, retighten Replace Replace Replace Replace Readjust Polish Replace Add distilled water Replace |
| Excessive charging | <ol style="list-style-type: none"> 1. Wiring <ul style="list-style-type: none"> • P terminal circuit and F terminal circuit shorted resulting in split wound generator. 2. Battery <ul style="list-style-type: none"> • Internal short. 3. Regulator <ul style="list-style-type: none"> • Excessive voltage at no load voltage. • Defective grounding. <ul style="list-style-type: none"> • Broken coil lead wire. | Repair Replace Repair Provide proper ground Repair, replace |
| Unstable charging voltage | <ol style="list-style-type: none"> 1. Wiring <ul style="list-style-type: none"> • Bare wire shorting intermittently under vibration or broken wire making partial contact. 2. Generator <ul style="list-style-type: none"> • Layer short (intermittent shorting) 3. Generator <ul style="list-style-type: none"> • Intermittent open circuit in the coil. • Improperly adjusted voltage. • Defective key switch. • Dirty points. | Repair or replace Repair or replace Repair or replace Readjust Replace Clean |

CHARGING TEST

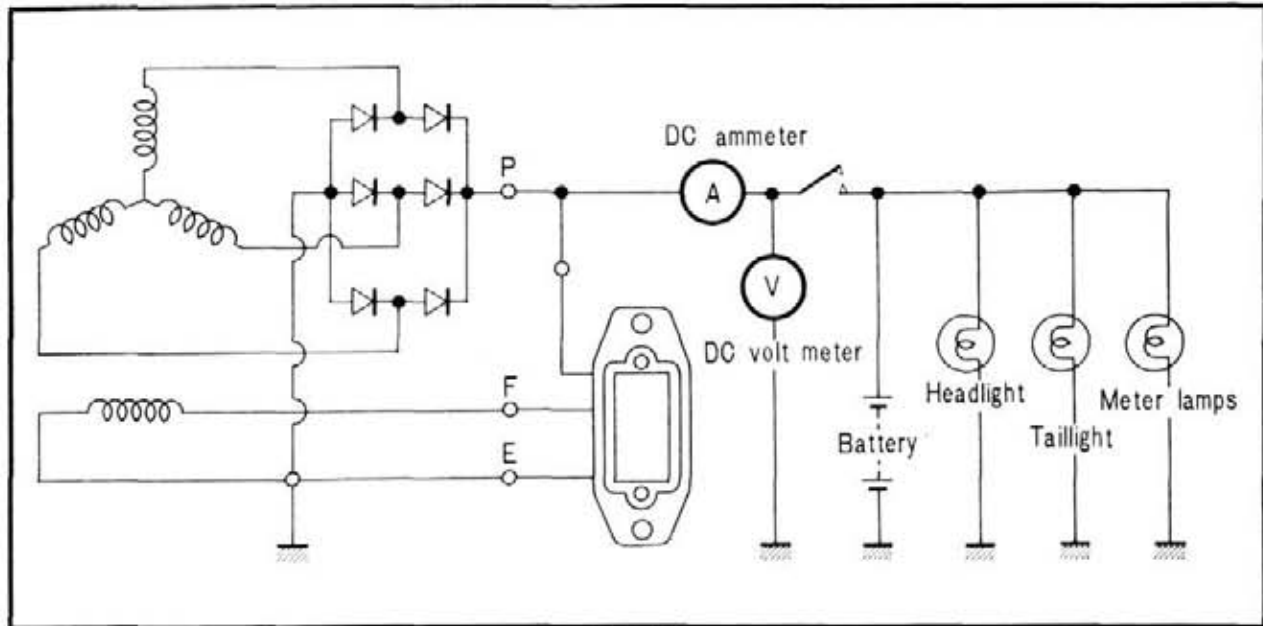


Fig. 8-3

1. Check the battery voltage in accordance with procedure described in the Battery Group, page 105. Make sure that the battery voltage is at 12 V, if not, charge the battery conducting the following test.
 2. From the battery (+) terminal remove the red/white selenium rectifier lead and the red power lead, and connect both to the (+) terminal of the ammeter. Next, connect the battery (+) terminal to the ammeter (-) terminal by using a wire lead.
 3. Start the engine and conduct the test for the following two modes :
 - a. Set the main key switch to the night riding position turning on only the headlight high beam.
 - b. Set main key switch to day riding position, however, do not turn on the turn signal or the stop lights.
 4. Operate the engine at the different speed listed in the table below and check to see if the measured value corresponds to those shown.
If the measured values are below the rated current, adjust the regulator in accordance with next section on page 100~101.
- Note :** The charge current may fluctuate slightly depending upon the charge condition of the battery.
5. Also, check the battery terminal voltages for the respective engine RPM. The rated voltages are shown in the table below.

| Engine (rpm) | 1,000 | 2,000 | 3,000 | 4,000 | 5,000 | 6,000 | 7,000 | 8,000 |
|------------------------------|-------|-------|-------|-------|-------|-------|-------|-------|
| Charging current (A) | | | | | | | | |
| Night riding | 6.5 | 0 | 2.4 | 1.3 | 1.0 | 1.0 | 0.8 | 0.6 |
| Day riding | 2-3 | 1 | 1 | 1 | 1 | 1 | 1 | 1 |
| Battery terminal voltage (V) | 12 | 12.4 | 13.2 | 14.5 | 14.5 | 14.5 | 14.5 | 14.5 |

8-2 ALTERNATOR

a. Description

The alternator consists of the field coil, stator coil and the rotor. Field coil and the stator coil are mounted on the dynamo cover while the rotor is mounted on the crankshaft (Fig. 8-4).

b. Disassembly

1. Remove the dynamo cover and pull out the generator rotor using the rotor puller (Tool No. 07933-3000000) (Fig. 8-5)
2. Remove the stator coil from the dynamo cover by unscrewing the four 6mm bolts (Fig. 8-6).
3. Remove the field coil from the dynamo cover by unscrewing the three screws (Fig. 8-7).

c. Inspection

1. Field coil continuity test

The insulation and open circuit condition of the field coil winding is checked with a tester. If there is continuity between the lead wires and the core, the coil is grounded and if there is no continuity between the two lead wires, the coil has an open circuit, in either case, the coil is defective and must be replaced. The rated resistance value is 7.2Ω . (Fig. 8-8)

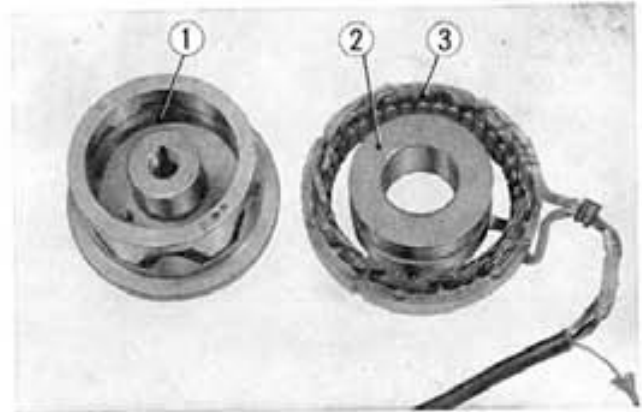


Fig. 8-4 ① Generator rotor
② Field coil ③ Stator coil

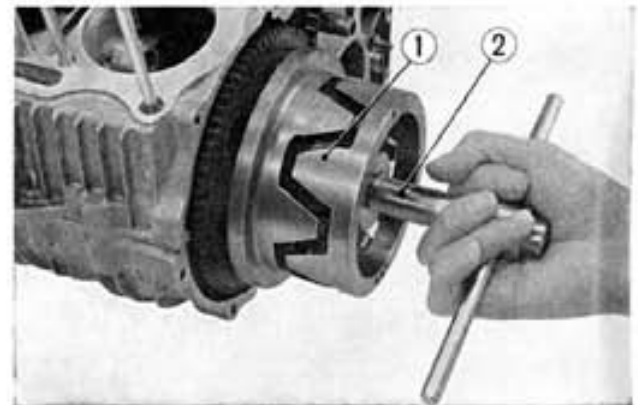


Fig. 8-5 ① A.C generator rotor
② Rotor puller

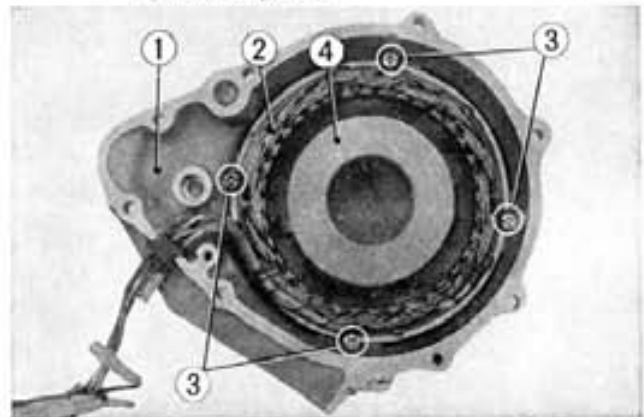


Fig. 8-6 ① Dynamo cover ③ 6mm cross screws
② Stator coil ④ Field coil

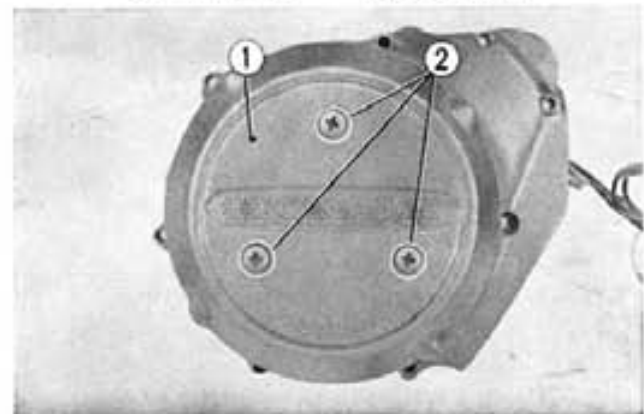


Fig. 8-7 ① Dynamo cover
② 6 mm cross screws



Fig. 8-8 ① Field coil
② Tester

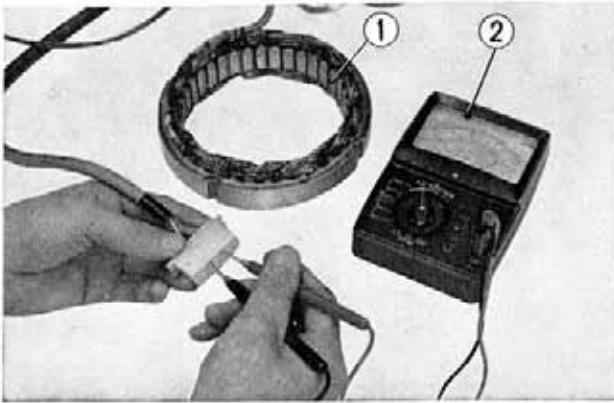


Fig. 8-9 ① Stator coil
② Tester

2. Stator coil continuity test

The insulation and open circuit condition of the stator coil is checked with a tester. If there are no continuity between the three terminals, the coil has an open circuit, in either case, the coil is defective and must be replaced. The rated resistance value is 0.2 Ω, (Fig. 8-9)

d. Reassembly

Reassembly is performed in the reverse order of disassembly.

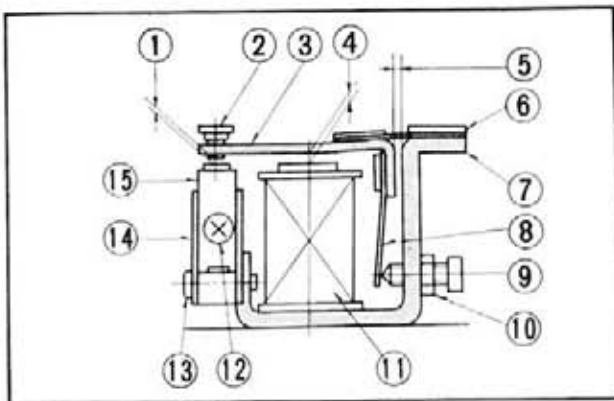


Fig. 8-10 ① Point gap
② Lower contact
③ Armature
④ Core gap
⑤ Yoke gap
⑥ Spring
⑦ Yoke
⑧ Adjusting spring
⑨ Voltage adjusting screw
⑩ Lock nut
⑪ Coil
⑫ Point gap adjusting screw
⑬ Core gap adjusting screw
⑭ Contact set
⑮ Upper contact

8-3 REGULATOR

a. Description

The regulator is a dual contact type regulator and it functions by opening or closing the resistance circuit to the alternator field coil; in this way, the output voltage is maintained at a constant level.

It is mounted in the center of the frame within the battery cover. (Fig. 8-10)

b. Disassembly

1. Detach the battery cover and remove the regulator by unscrewing the two setting bolts. (Fig. 8-11)
2. Remove the regulator cover by unscrewing the two setting screws.

c. Inspection

1. If an adjustment is necessary to the regulator after checking the voltage or charging current by the procedure outlined in the test section, perform the adjustment by the following manner.

If the charging current or battery voltage is too low, loosen the voltage adjusting screw lock nut and turn the adjusting screw clockwise. If the charging current or battery voltage is excessively high, turn the screw in the opposite direction. (Fig. 8-12)

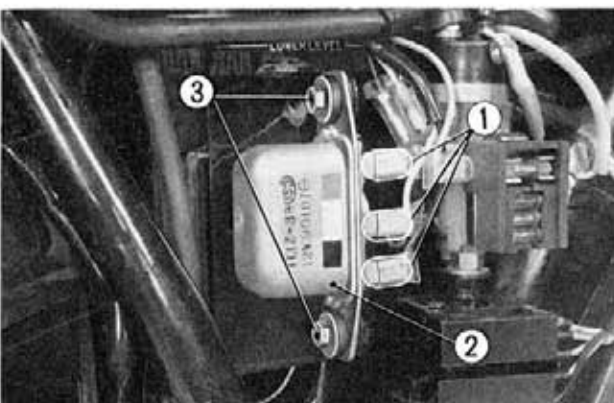


Fig. 8-11 ① Connectors
② Regulator
③ Regulator setting bolts

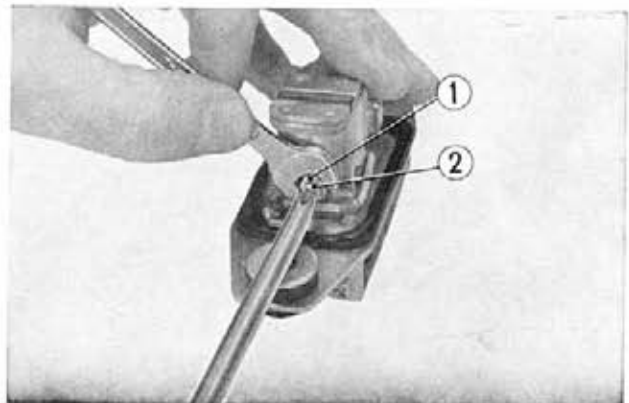


Fig. 8-12 ① Adjusting screw lock nut
② Adjusting screw

Note: The voltmeter indicates an output of 14~15 V at 5,000 rpm at no load, the circuit is satisfactory.

- After completing the adjustment, reinstall the regulator cover and perform a recheck of the voltage.

Note: There will be a 0.5V rise in voltage when the low speed contacts changes to the high speed contacts in the regulator. (Fig. 8-13)

If the change in voltage is higher than 0.5V or if there is a drop in voltage, core gap should be adjusted by referring to next paragraph.

- Core gap adjustment

If the surface of the points are dirty or pitted, use a fine grade emery paper and clean up the points. Check the core gap with a thickness gauge to see if it is within the specified limits, 0.024~0.04 in. (0.6~1.0 mm). Core gap can be adjusted by loosening the adjusting screw. (Fig. 8-14)

- Point gap adjustment

If the surface of the points and if they are dirty or pitted, use a fine grade emery paper and clean up the points. Check the gap with a thickness gauge. Standard gap is 0.12~0.016 in. (0.3~0.4 mm). If necessary to adjust, loosen the point gap lock screw, then tighten the screw after adjustment. (Fig. 8-15)

d. Reassembly

Reassembly is performed in the reverse order of disassembly.

8-4 SILICON RECTIFIER

a. Description

As the rotor rotates three phase alternation currents are induced in the stator coil. However, the currents are rectified to D.C currents by the six silicon diodes which are in one unit and attached to the center of the frame. The silicon rectifier requires cooling and complete condition in negative terminal by which the rectifier is attached to the frame. Therefore it is necessary to take special care for attachment. (Fig. 8-16)

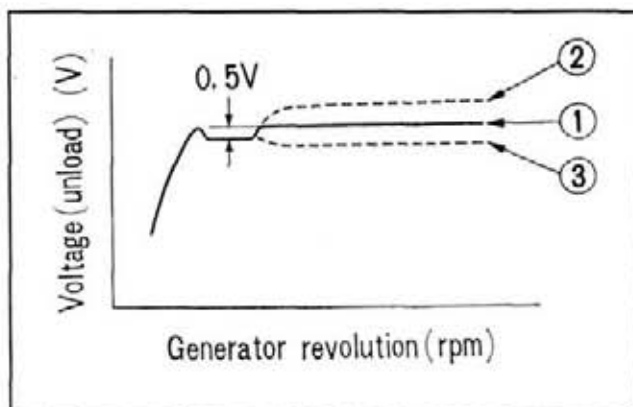


Fig. 8-13 ① Standard ② Wide core gap ③ Narrow core gap

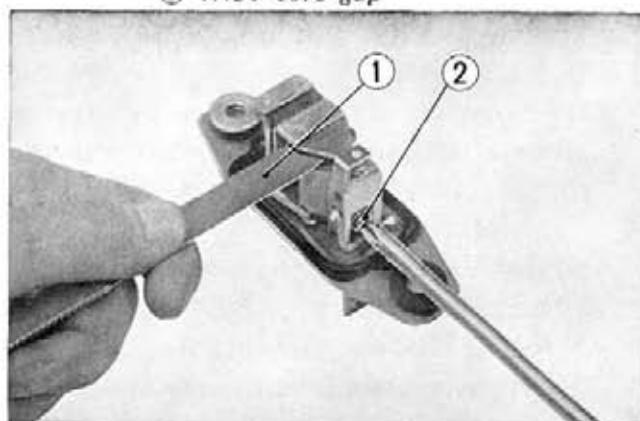


Fig. 8-14 ① Thickness gauge ② Core gap adjusting screw

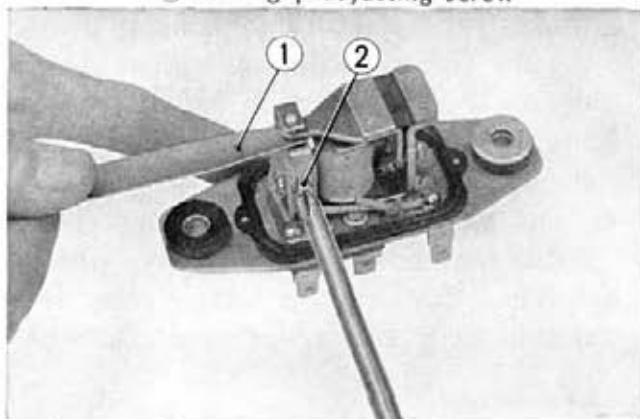


Fig. 8-15 ① Thickness gauge ② Point gap lock screw

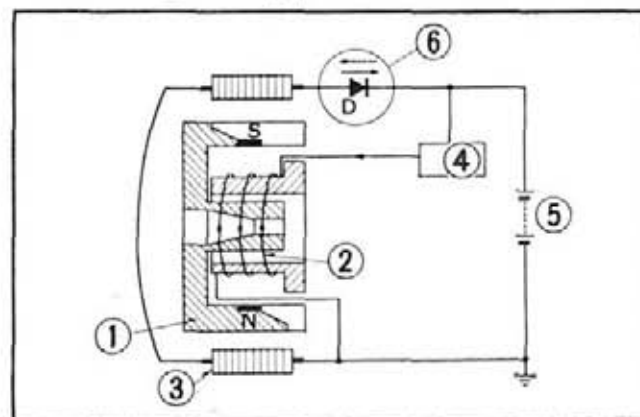


Fig. 8-16 ① Generator rotor ② Field coil ③ Stator coil ④ Regulator ⑤ Battery ⑥ Silicon rectifier

b. Disassembly

Detach the battery cover and remove the silicon rectifier by unscrewing a setting nut. (Fig. 8-17)

c. Inspection

1. The condition of the silicon rectifier is tested by disconnecting it from the generator and testing the rectifier function in both the normal and reverse directions. A continuity in only one direction indicates a good condition. Continuity in both directions or no continuity in either direction indicates a defective rectifier and should be replaced. (Fig. 8-18)

Note: Do not use a megger for testing since it will expose the silicon diodes to excessively high voltage and cause damages.

2. Observe the following precautions.
 - a. Battery polarity should be strictly observed, do not connect the battery in reverse. Reversing the battery connection will cause the battery to become shorted, resulting in a large current to flow through the electrical system and damaging the silicon rectifier as well as burning up the wiring harness.
 - b. Care should be exercised to assure that the electrical terminals are not connected in reverse.
 - c. Do not operate the generator at high speed with the "P" terminal of the rectifier disconnected. The high voltage produced may cause damage to the silicon rectifier.
 - d. When charging the battery from an external source such as quick charging, the lead should be disconnected from the 'P' terminal of the rectifier.

d. Reassembly

Reassembly is performed in the reverse order of disassembly.

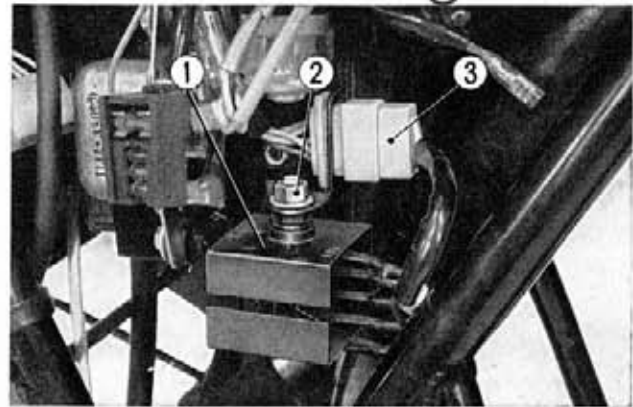


Fig. 8-17 ① Silicon rectifier ② Rectifier setting nut ③ Connector

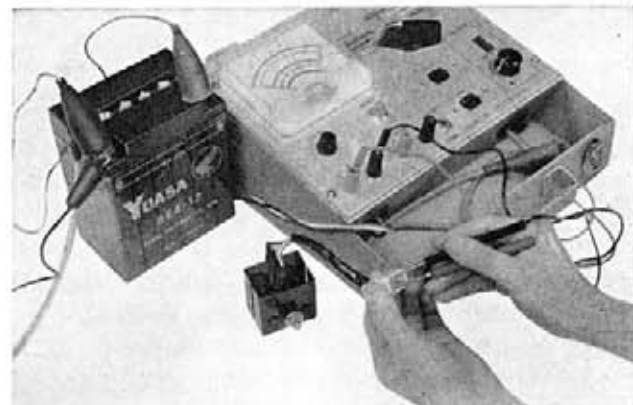


Fig. 8-18

STARTING SYSTEM

GROUP

9

CONTENTS

| | |
|--|-----|
| 9-1 GENERAL DESCRIPTION | 103 |
| DESCRIPTION | 103 |
| SPECIFICATIONS | 104 |
| DIAGNOSIS | 104 |
| 9-2 STARTING MOTOR | 105 |
| a. Description | 105 |
| b. Disassembly | 105 |
| c. Inspection | 105 |
| d. Reassembly | 106 |
| 9-3 STARTING CLUTCH | 106 |
| a. Description | 106 |
| b. Disassembly | 106 |
| c. Inspection | 106 |
| d. Reassembly | 106 |
| 9-4 STARTER MAGNETIC SWITCH | 107 |
| a. Description | 107 |
| b. Disassembly | 108 |
| c. Inspection | 108 |
| d. Reassembly | 108 |

9-1 GENERAL DESCRIPTION

DESCRIPTION

A push button type starter switch is located on the right side of the handle bar. When pressed, it engages the starter magnetic switch in the starter circuit to close the starting circuit.

Approximately 120A current flows from the battery to operate the starting motor. (Fig. 9-1)

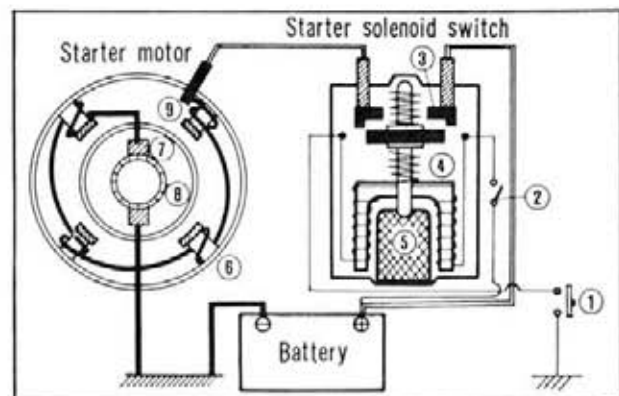


Fig. 9-1

- | | |
|-------------------------|--------------|
| ① Starter button switch | ⑥ Pole |
| ② Ignition switch | ⑦ Brush |
| ③ Contact unit | ⑧ Armature |
| ④ Excitation coil | ⑨ Field coil |
| ⑤ Plunger | |



SPECIFICATIONS

| | | | |
|---------------------------|---------------------------------------|---------------|---------------|
| Starting motor | | | |
| Rated voltage | 12V | | |
| Rated output | 0.6kW | | |
| Rated operation | 30seconds | | |
| Direction of rotation | Counterclockwise (viewing into shaft) | | |
| Weight | 5.3lbs (2.4kg) | | |
| | Without load | With load | Stalling load |
| Voltage | 11V | 8.5V | 5V |
| Amperage | Max. 35A | 120A | Max. 280A |
| Torque | — | Min. 0.12kg-m | Min. 0.32kg-m |
| Revolution | 11,000~22,000rpm | Min. 3,200rpm | — |
| Primary reduction ratio | 4.7 : 1 | | |
| Secondary reduction ratio | 4.69 : 1 | | |
| Total reduction ratio | 22.04 : 1 | | |
| Starter magnetic switch | | | |
| Rated voltage | 12V | | |
| Operating voltage | 7.5V | | |

| Item | Standard value | Serviceable limit |
|---------------------|------------------------|-------------------|
| Carbon brush length | 0.472~0.512in. 12~13mm | 0.217in. 5.5mm |
| Mica undercut | | 0.012in. 0.3mm |
| Carbon brush spring | 500~600gr | — |

DIAGNOSIS

| Trouble | Probable Causes | Remedy |
|---------------------------------|--|---|
| Starting motor does not operate | <ol style="list-style-type: none"> 1. Defective battery 2. Poor contact of magnetic switch 3. Poor contact of starting motor carbon brush | Charge or replace Repair or replace Repair or replace |

9-2 STARTING MOTOR

a. Description

The starting motor is mounted in the upper crankcase behind the cylinder and drive the crankshaft through the starting clutch gear.

The primary reduction is accomplished by the starting motor reduction gear and the secondary reduction is by the starting clutch gear. (Fig. 9-2)

b. Disassembly

1. Remove the left side cover and disconnect the starting motor cable from the magnetic switch. (Fig. 9-3)
2. Remove the starting motor cover from the upper crankcase and detach the starting motor. (Fig. 9-4)
3. Remove the starting motor side cover.
4. Unscrew the brush mounting screws and remove the brushes from the brush holders. (Fig. 9-5)

c. Inspection

1. Checking the carbon brush length
Measure the length of the starting motor brush using a vernier caliper to determine amount of wear. If it is less than 0.217 in. (5.5 mm), the brush should be replaced (Fig. 9-6)

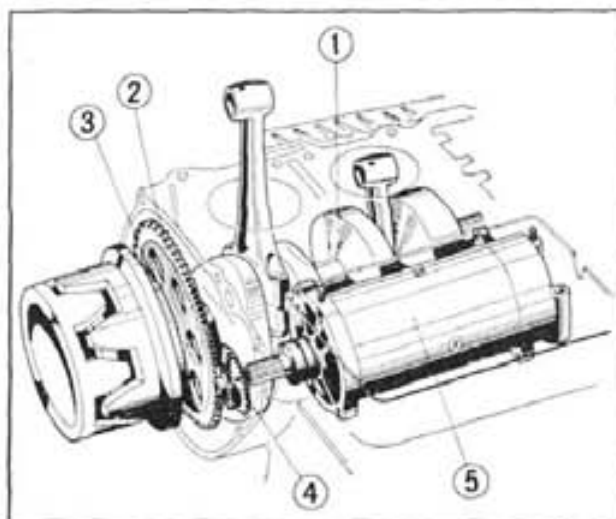


Fig. 9-2 ① Crankshaft
② Starting clutch gear
③ Starting clutch
④ Starting motor reduction gear
⑤ Starting motor

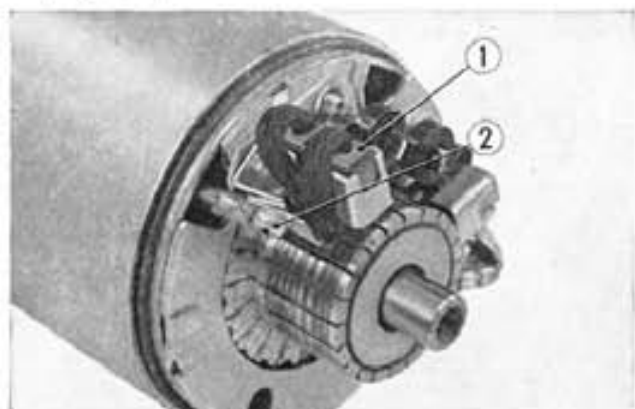


Fig. 9-5 ① Brush ② Brush mounting screw

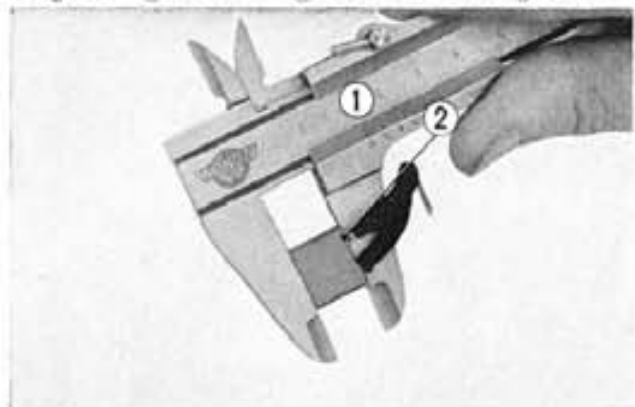


Fig. 9-6 ① Vernier caliper ② Carbon brush



Fig. 9-3 ① Magnetic switch
② Starting motor cable

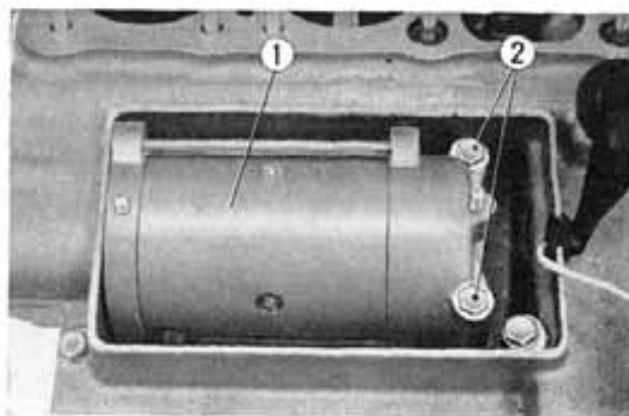


Fig. 9-4 ① Starting motor
② Motor setting bolts

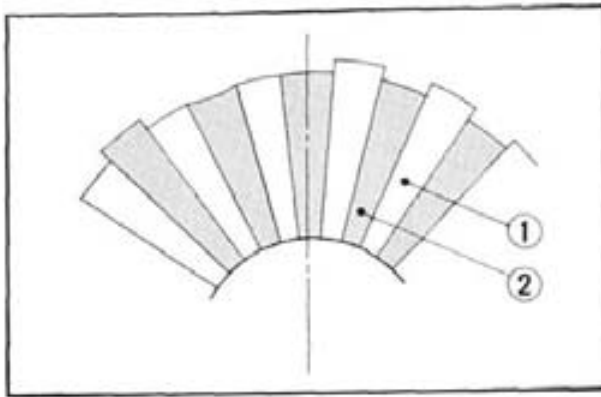


Fig. 9-7 ① Commutator
② Mica

2. Checking the amount of mica undercut.
Measure the amount of mica undercut and if the difference in height is less than **0.012 in. (0.3 mm)**, it should be repaired. It is recommended that this repair be performed by a specialist. (Fig. 9-7)

3. Armature insulation test

Perform a continuity test between the commutator and the shaft mounting area. If a short is indicated, a defect is in the armature and, therefore, it should be replaced.

4. Measuring the starting current.

The current draw of the starting motor can be measured with the Honda service tester by using external shunt (refer to the service tester operational manual for the testing procedure)

The starting motor should conform to the standard value shown in the specification on page 104.

d. Reassembly

Perform the reassembly in the reverse order of disassembly.

9-3 STARTING CLUTCH

a. Description

The one way clutch is used for starter clutch which incorporates the A.C. generator rotor connected to the crankshaft. As the rotation of the starting motor is transmitted to the starting clutch gear, the rollers within the starting clutch will move the narrow section of the slot to lock the starting clutch (lock to A.C. generator rotor) and ensuring the starting clutch to rotate. (Fig. 9-8)

Since the generator rotor is mounted on the crankshaft with a key, the crankshaft will rotate and causes the engine to start. After the engine starts and the crankshaft speed exceeds the speed of the starting clutch gear, the roller between the starting clutch gear and the clutch outer will move toward the wide section of the groove due to centrifugal force and the transmission of the rotating force will no longer be transmitted. As a result, the crankshaft rotation will no longer be transmitted to the starting motor.

b. Disassembly

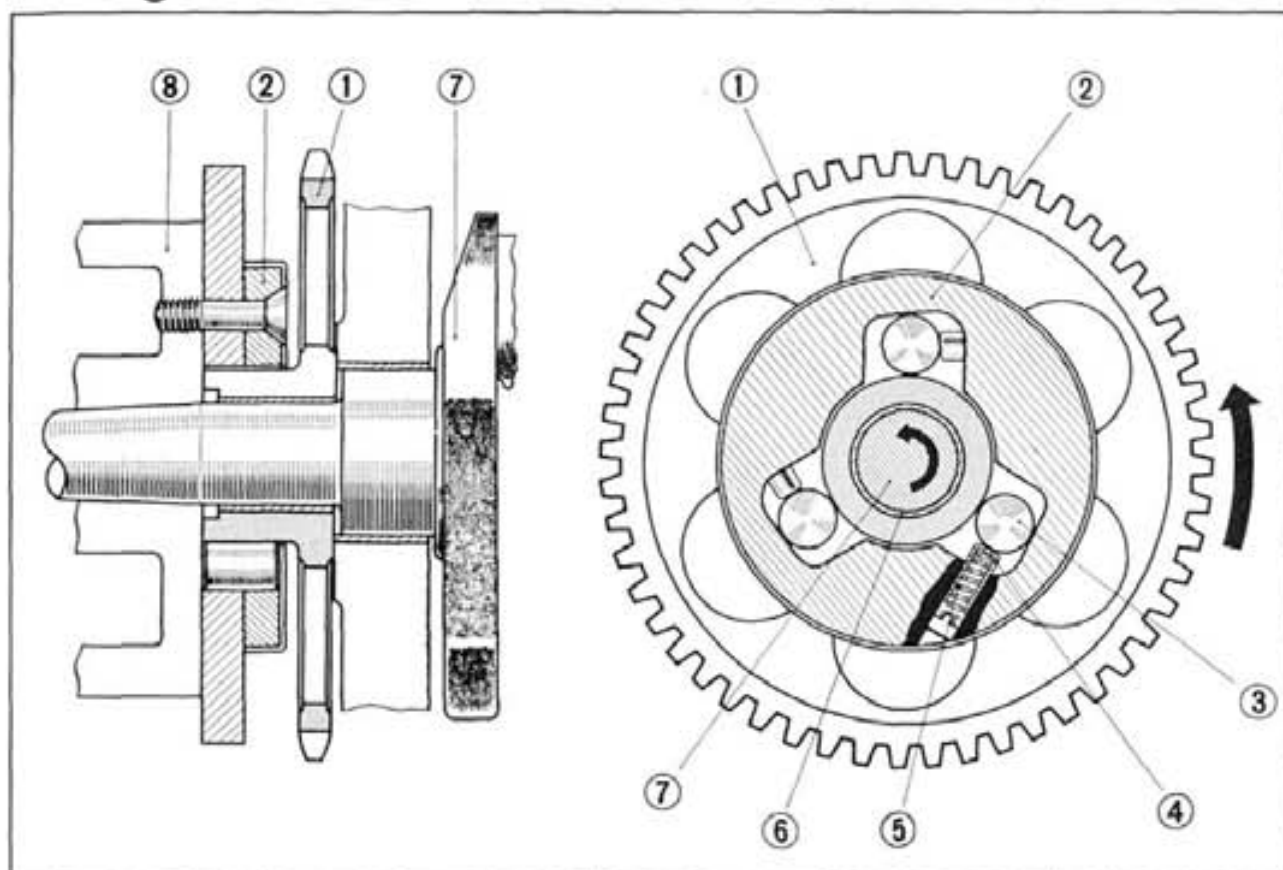
Perform the disassembly in accordance with 3-6 b on page 46.

c. Inspection

1. Check to make sure that the clutch roller operates smoothly.
2. Inspect the starting clutch for defect.

d. Reassembly

Perform the reassembly in accordance with 3-6 d on page 53.



- | | | |
|------------------------|---------------------|----------------------|
| ① Starting clutch gear | ④ Roller spring cap | ⑦ Crankshaft |
| ② Starting clutch | ⑤ Roller spring | ⑧ AC generator rotor |
| ③ 15 mm x 13 roller | ⑥ Bush | |

Fig. 9-8

9-4. STARTER MAGNETIC SWITCH

a. Description

A large current is required to operate the starter and if the starter circuit was connected directly to the push button switch on the handle, the switch will burn out. A starter solenoid of a large capacity is installed between the battery and the starting motor. When the push button switch is pressed, the solenoid coil is energized, creating an electromagnet which draws the iron core. A heavy duty electrical contacts are mounted to this iron core which closes the circuit between the battery and the starting motor. (Fig. 9-9)

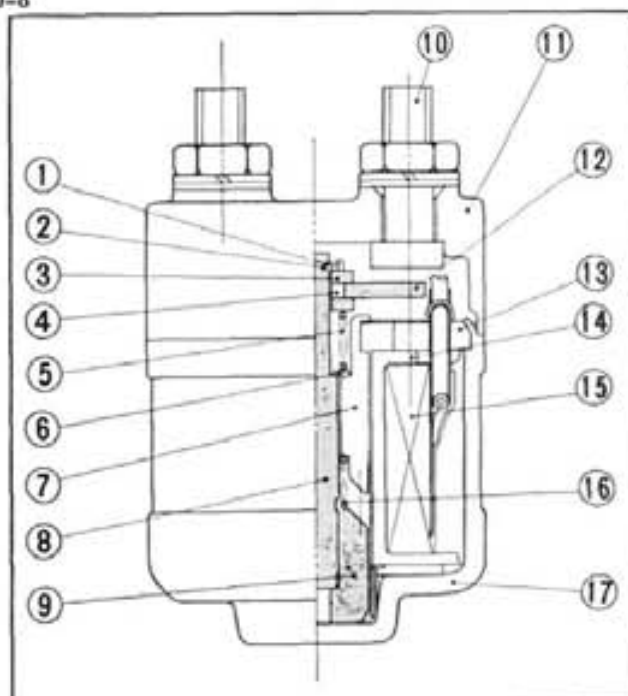


Fig. 9-9

- | | |
|-----------------------|-----------------|
| ① Stopper | ⑩ Contact bolt |
| ② Stopper holder | ⑪ Case |
| ③ Insulation washer | ⑫ Contact plate |
| ④ Insulation collar A | ⑬ Yoke |
| ⑤ Contact spring | ⑭ Coil bobbin |
| ⑥ Flat washer | ⑮ Coil complete |
| ⑦ Plunger holder | ⑯ Return spring |
| ⑧ Plunger shaft | ⑰ Body |
| ⑨ Plunger | |

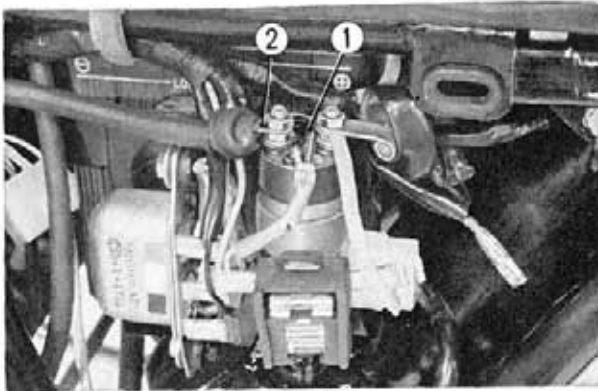


Fig. 9-10 ① Magnetic switch
② Starting motor cable

b. Disassembly

1. Remove the left side cover, disconnect the electric lead to the magnetic switch and then remove the magnetic switch. (Fig. 9-10)
2. Remove the cover.

c. Inspection

1. Press the starter switch listen for the click in the magnetic switch, it is an indication that the plunger within the magnetic switch is functioning.
2. If the magnetic switch has been used for a long period, the contacts will become

pitted or burned, creating a high resistance which will prevent flow of current to properly operate the starting motor. When such condition develops, dress the contact points with a file or sand paper.

d. Reassembly

Reassembly is performed in the reverse order of the disassembly procedure.

BATTERY

GROUP

10

CONTENTS

| | |
|--|-----|
| 10-1. GENERAL DESCRIPTION | 109 |
| DESCRIPTION | 109 |
| SPECIFICATIONS | 109 |
| DIAGNOSIS | 109 |
| 10-2. REPAIRING PROCEDURE | 110 |
| a. Disassembly | 110 |
| b. Inspection | 110 |
| c. Reassembly | 113 |

10-1. GENERAL DESCRIPTION

DESCRIPTION

The 12V-14AH battery is mounted under the seat. The service life of the battery depends upon the maintenance it receives.

The following instructions must be carefully observed.

SPECIFICATIONS

| | |
|------------------------------|---|
| Type | Yuasa B64-12 (Vacuum sealed dry charged battery) |
| Battery voltage | 12V |
| Capacity rating | 14AH |
| Electrolyte specific gravity | 1.26~1.28 at 20°C (68°F) |

DIAGNOSIS

| Trouble | Probable Cause | Remedy |
|--|---|---|
| Sulfation The electrode plates are covered with white layer or in spots. | <ol style="list-style-type: none">1. Charging rate is too small or else excessively large.2. The specific gravity or the mixture of the electrolyte is improper.3. Battery left in a discharge condition for a long period. (Left with the switch turned on).4. Exposed to excessive vibration due to improper insulation.5. Motorcycle stored during cold season with battery connected. | <ol style="list-style-type: none">1. When motorcycle is in storage, the battery should be recharged once a month even though the motorcycle is not used.2. Check the electrolyte periodically and always maintain the proper level.3. In a lightly discharge condition, performing recharging and discharging several times by starting the engine may be sufficient. |

| Trouble | Probable cause | Remedy |
|--|---|--|
| Self discharge Battery discharges in addition to that caused by the connected load. | <ol style="list-style-type: none"> 1. Dirty contact areas and case. 2. Contaminated electrolyte or electrolyte excessively concentrated | <ol style="list-style-type: none"> 1. Always maintain the exterior clean 2. Handle the replenishing electrolyte with care and use clean container. |
| C. Large discharge rate Specific gravity gradually lowers and around 1.100 (S.G) the winker and the no longer function. | <ol style="list-style-type: none"> 1. The fuse and the wiring is satisfactory, loads such as winker and horn does not function. In this condition the motorcycle will operate but with prolong use, both \oplus and \ominus plates will react with the sulfuric acid and form lead sulfide deposits, (sulfation) making it impossible to recharge. | <ol style="list-style-type: none"> 1. When the specific gravity falls below 1.200 (20°C : 68°F), the battery should be recharged immediately. 2. When the battery frequently becomes discharged while operating at normal speed, check the generator for proper output. 3. If the battery discharges under normal charge output, it is an indication of overloading, remove some of the excess load |
| High charging rate The electrolyte level drops rapidly but the charge is always maintained at 100 % and the condition appears satisfactory. A condition which is overlooked. (Specific gravity over 1.260) | <ol style="list-style-type: none"> 1. The deposit will heavily accumulate at the bottom and will cause internal shorting and damage the battery. | <ol style="list-style-type: none"> 1. Check to assure proper charging rate. 2. When overcharge condition exist with the proper charging rate, place on appropriate resistor in the charging circuit. |
| Specific gravity drops Electrolyte evaporates | <ol style="list-style-type: none"> 1. Shorted 2. Insufficient charging 3. Distilled water overfilled 4. Contaminated electrolyte | <ol style="list-style-type: none"> 1. Perform specific gravity measurement. 2. If the addition of distilled water causes a drop in specific gravity, add sulfuric acid and adjust to proper value. |

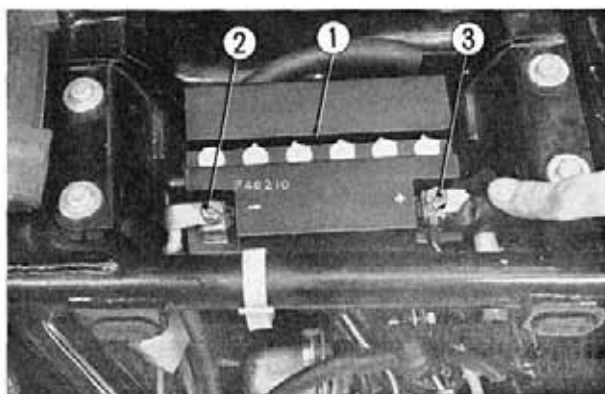


Fig. 10-1 ① Battery ② \ominus terminal ③ \oplus terminal

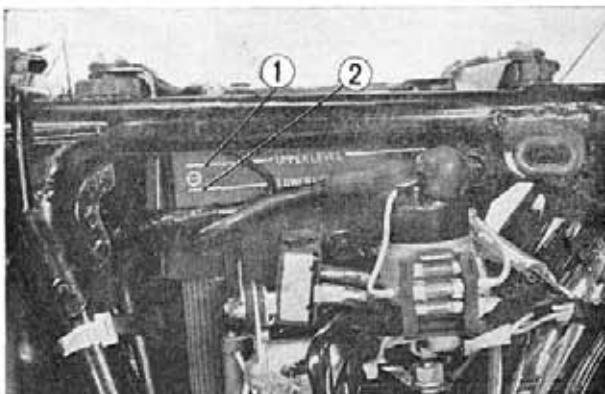


Fig. 10-2 ① Upper level mark ② Lower level mark

10-2. REPAIRING PROCEDURE

a. Disassembly

1. Raise the seat and remove the battery band from the battery.
2. Disconnect the ground \ominus negative cable connection first and the positive \oplus last. (Fig. 10-1)
3. Remove the battery from the battery compartment.

b. Inspection

1. Checking the battery electrolyte level
Remove the left side cover at the frame center and observe the battery electrolyte level marking on the side of the battery to make sure that the electrolyte level is between the upper and lower marks. (Fig. 10-2)



To correct the electrolyte level, remove the battery cell caps from the cells needing level correction. For ease of cell level correction a small syringe or plastic funnel should be used. Carefully add the proper amount of distilled water to bring the electrolyte level of the cells between the lower and upper marks. For maximum battery performance and life, only distilled water should be added, however, in an emergency situation where electrolyte level is found to be low and distilled water is not available, drinking water of a low mineral content can be used. Reinstall the cell caps. (Fig. 10-3)

2. Check the specific gravity of the battery electrolyte

The specific gravity is measured with a hydrometer, the type shown in Fig. 10-4. When making a reading of the measured value, the electrolyte level in the hydrometer should be held at the eye level and the scale read at the fluid level. Temperature of the electrolyte can be measured by a rod thermometer. (Fig. 10-4)

The relation between the battery capacity and the specific gravity (residual capacity) is shown in Fig. 10-5. When the specific gravity is 1.189 at 20°C (68°F) (less than 50%) the residual capacity is small and if continued to be used in such a condition, it will eventually lead to trouble as well as shortening the battery life, therefore, the battery should, under such a condition, be recharged as soon as possible. (Fig. 10-5)

The electrolyte used in the battery must be comprised of pure sulfuric acid diluted to the designated specific gravity. The specific gravity will vary with the temperature, therefore, the specific gravity index is based on the electrolyte temperature of 20°C (68°F). The temperature correction formula should be used to derive at the proper specific gravity for the measure temperature of the electrolyte.

$$S_{20} = St + 0.0007 (t - 20)$$

Where:

S₂₀ = Specific gravity of the electrolyte corrected to 68°F (20°C)

St = Specific gravity of the electrolyte measured temperature, t°C

t = Temperature of the measured electrolyte

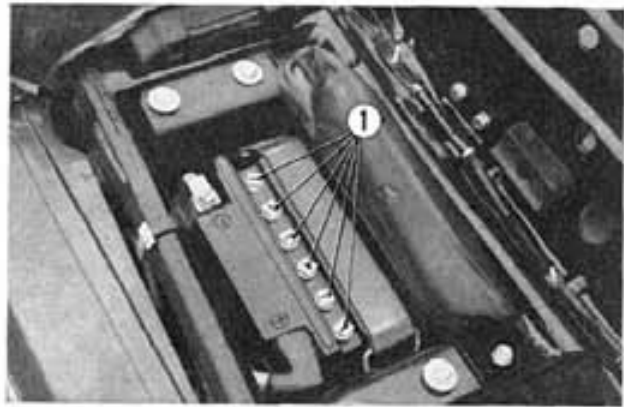


Fig. 10-3 ① Battery cell caps

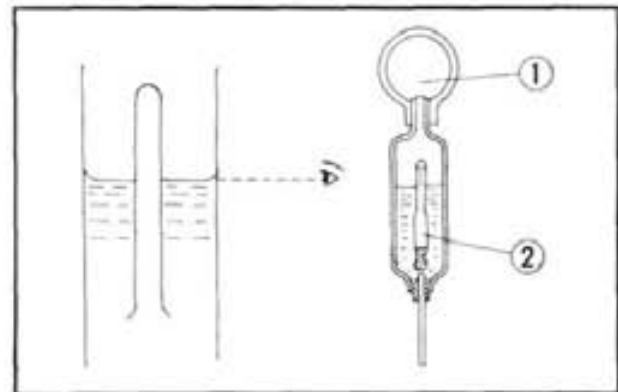


Fig. 10-4 ① Hydrometer
② Float

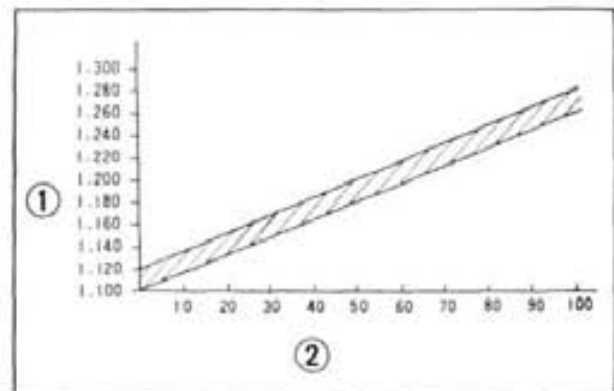


Fig. 10-5 ① Specific gravity (20°C)
② Residual capacity (%)

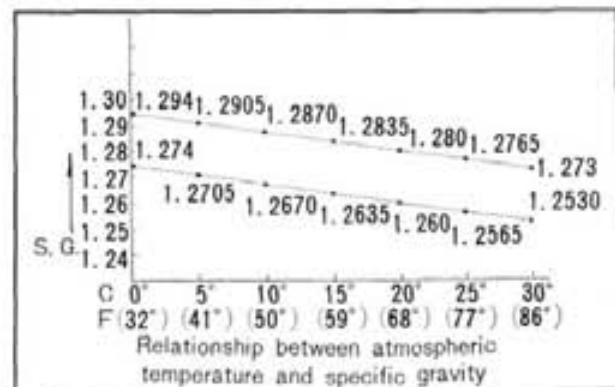


Fig. 10-5-1

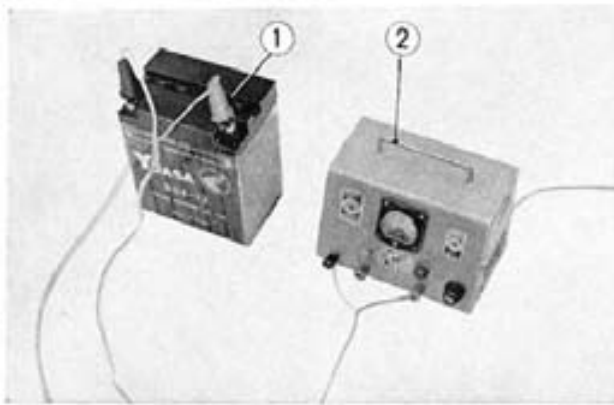


Fig. 10-6 ① Battery ② Battery charger

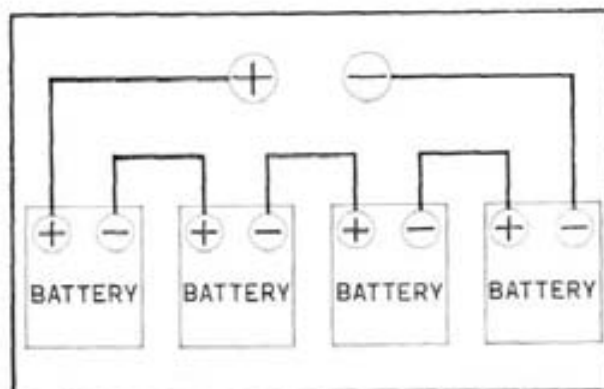


Fig. 10-7

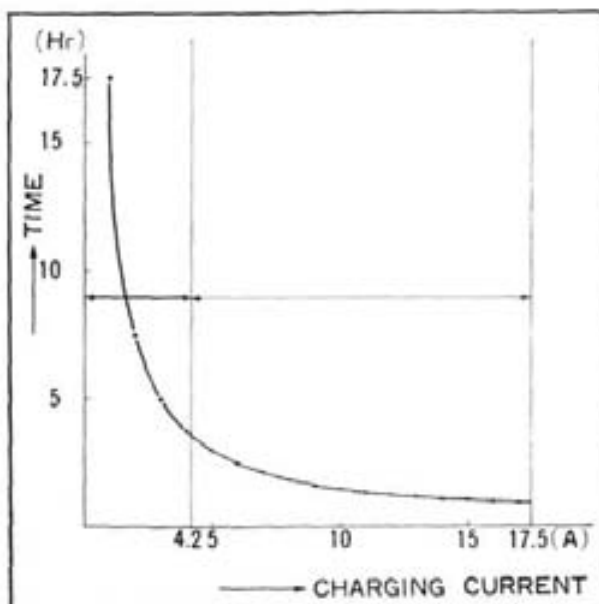


Fig. 10-8

3. Battery charging procedure

There are two methods of charging of a battery, namely, the constant current method and the constant voltage method. In the constant current method, the battery is charged at a constant current throughout the charging period. This method is safe and is recommended for initial charging of the battery. In the constant voltage charging method, a constant voltage is applied during the charging period. In this method, the charging period can be shortened by applying a larger current, however, one drawback is that if too large a current is applied, the battery will overheat.

• Charger hook-up

Connect the positive terminal \oplus and the negative battery terminal \ominus to the respective terminal of the charger. (Fig. 10-6)

When more than one battery is to be charged at once, they should be connected in series, as shown in Fig. 10-7.

The charger voltages must be the sum of the battery voltages. For example, to charge three 12V batteries, the charger must have an output voltage in excess of $16 (15) + 16 (15) + 16 (15)$ or 48 (or 45) volts.

A fully discharged battery will require charging rate that is 1.25 higher than the normal charge rate of the battery. As an example, a 14AH battery will require 17.5AH charging rate ($14\text{AH} \times 1.25 = 17.5\text{AH}$). There is a definite relationship between the charging current and the charging time. This is shown in Fig. 10-8. The charging current should not be greater than three times the 10 hours current rate. (For a 14AH battery, $1.4\text{A} \times 3 = 4.2\text{A}$).

As the battery approaches the full charge condition, gas will be released from the electrolyte. At this time, check the battery electrolyte to see if the specific gravity is up to the standard value of 1.26~1.28, and the terminal voltage is up to the standard value of 15~16V. Perform the check again after 30 minutes and again in an hour, and if for the three checks the values are constants, the battery is fully charged and the charging can be terminated. (Fig. 10-8)

Note: If during the charging process the temperature of the electrolyte should raise above 45°C (113°F) or if the gas is being released from the electrolyte in abundance, the charging should be stopped temporarily or the charging current reduced to a lower rate.

• Quick charger

Quick charger should not be on battery which has been fully discharged. Further, quick charging method should not be frequently used. However, when it is inevitable and quick charging must be performed, the following items should be observed.

For quick charging a 14AH battery, use the charging current rate of 14A. A battery which is 50% discharged, approximately 30 minutes should be adequate to charge the battery. However, if during the charging process the electrolyte temperature should raise above 50°C (122°F), the charging should be temporarily stopped or the charging current rate reduced.

Note: Disconnect the silicon diode P terminal when quick charging the battery.

• Other precaution

If the electrolyte level falls during charging, refill with distilled water to the upper level mark.

Inflammable hydrogen gas is discharged from the cells, therefore, do not charge batteries near any open fire.

After charging, add distilled or battery water to the cells to bring the electrolyte to the upper mark.

Tighten cell caps firmly and wash off with clean water any acid spilled.

The battery is now ready for installation. When installing a battery in the motorcycle, be sure not to pinch the battery vent tube. Explosion may result if the exhaust tube is blocked.

4. Check the terminal voltage

The battery terminal voltage can be checked with a service tester. The standard battery voltage is 12V, however, immediately after charging, the voltage will be at 15~16V.

Set the selector knob to the D.C. VOLTAGE position on the tester and clamp the (+) tester lead to the (+) terminal of the battery and then connect the other tester lead to the (-) terminal of the battery and read the voltage off the blue scale. When performing battery charging, refer to the battery charging section. (Fig. 10-9)

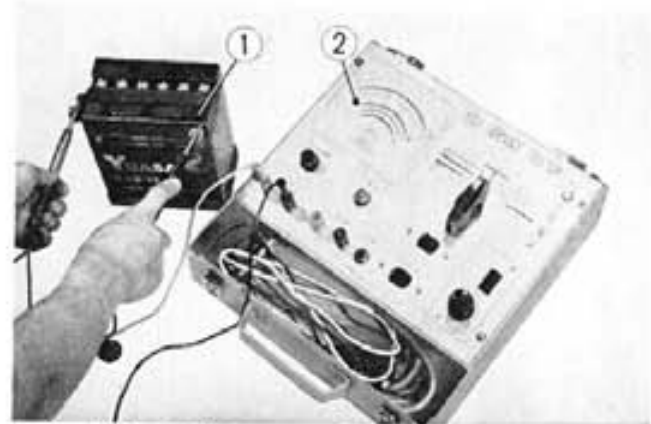


Fig. 10-9 ① Battery ② Tester

c. Reassembly

Battery installation is performed in the reverse order of removal. Pay particular attention the battery rubber mount pads and the vent tube routing. Connect and protect the positive (+) terminal with the rubber insulator first. Connect the negative (-) terminal second.

Note: Do not over tighten these terminal connection as damage to the battery terminals may result. Install battery retainer, lower the seat and install the left side cover.

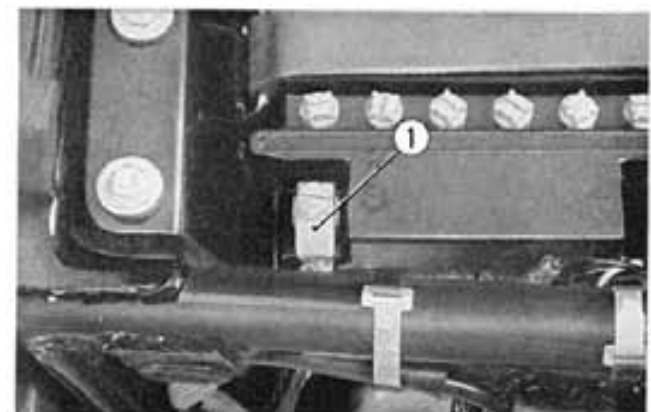


Fig. 10-10 ① Negative (-) terminal

STEERING AND FRONT SUSPENSION

GROUP 11

CONTENTS

| | |
|---------------------------------------|-----|
| 11-1 GENERAL DESCRIPTION | 115 |
| DESCRIPTION | 115 |
| SPECIFICATIONS | 115 |
| DIAGNOSIS | 116 |
| 11-2 STEERING | 117 |
| a. Description | 117 |
| b. Disassembly | 117 |
| c. Inspection | 118 |
| d. Reassembly | 118 |
| 11-3 FRONT SUSPENSION | 119 |
| a. Description | 119 |
| b. Disassembly | 120 |
| c. Inspection | 120 |
| d. Reassembly | 121 |

11-1 GENERAL DESCRIPTION

DESCRIPTION

The steering and the front suspension have been designed particularly to provide comfort and prevent riding fatigue caused from long distance traveling.

SPECIFICATIONS

| | |
|-----------------------|--------------------------------|
| Steering handle type | Up-handle type |
| Steering handle width | 31.89 in (810 mm) |
| Steering angle | 40° right and left from center |
| Front suspension type | Telescopic fork |
| Front fork oil | |
| Oil used | SAE 10 W-30 or its equivalent |
| Oil capacity | 7.0~7.3 ozs. (220~230 cc) |

| Item | Standard value | Serviceable limit |
|------------------------|--|-----------------------------|
| Front cushion spring | | |
| Spring outer diameter | 0.992~1.008 in 25.2~25.6 mm | — |
| Free length | 19.075 in 484.5 mm | 18.11 in 460 mm |
| Coil dia | 0.185 in 4.7 mm | — |
| Installation load | 17.579 in/71.2 lbs 446.5 mm/32.3 kg | — |
| Tilt | within 1.5° | Over 2.5° |
| Front fork piston | | |
| Outer diameter | 1.552~1.553 in 39.425~39.45 mm | 1.5512 in 39.4 mm |
| Taper, out of round | within 0.0003 in 0.008 mm | over 0.0006 in 0.015 mm |
| Front fork bottom case | | |
| Inner diameter | 1.555~1.556 in 39.50~39.534 mm | 1.5591 in 39.68 mm |
| Taper, out of round | within 0.0012 in 0.03 mm | over 0.0012 in (0.03 mm) |

DIAGNOSIS

| Trouble | Probable Causes | Remedy |
|------------------|--|---|
| Heavy steering | 1. Steering stem excessively tightened. 2. Damaged steering stem steel balls. 3. Bent steering | Loosen the steering stem nut. Replace Replace |
| Wheel wobble | Loose steering stem mounting bolts | Retorque |
| Soft suspension | 1. Loss of spring tension 2. Excessive load | Replace |
| Hard suspension | 1. Ineffective front cushion damper 2. Ineffective rear cushion damper | Repair Replace |
| Suspension noise | 1. Cushion case rubbing 2. Interference between cushion case and spring 3. Damaged cushion stopper rubber 4. Insufficient spring damper oil | Inspect cushion spring and case Repair or replace Replace Add damper oil |

11-2 STEERING

a. Description

The handle bar is mounted on the fork top bridge and is fixed with the two handle bar holders.

The fork top bridge is mounted on the front forks with the two front fork top bolts, the fork top bridge in turn is mounted to the steering stem with the steering stem nut.

The steering stem is mounted on the frame head pipe and pivots on the upper and lower sets of the ball bearings. (Fig. 11-1)

b. Disassembly

1. Remove the master cylinder body by unscrewing the two master cylinder body mounting bolts and disconnect the clutch cable from the clutch lever. (Fig. 11-2)
2. Remove the starter lighting ignition switch and disconnect the throttle cable from the throttle grip pipe.
3. Detach the headlight assembly from the headlight case and disconnect the wiring at the connectors.
4. Remove the two upper handle holders and then remove the handle bar. (Fig. 11-3)

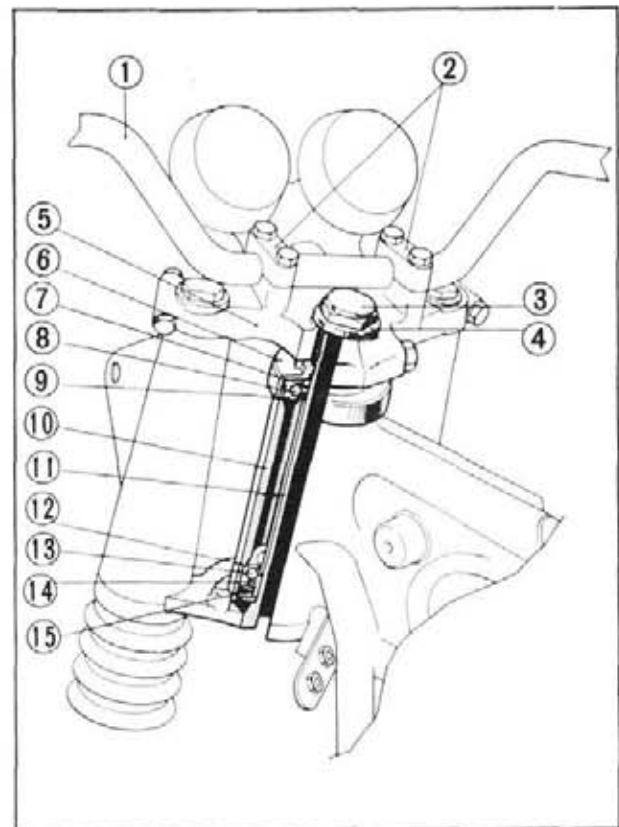


Fig. 11-1 ① Steering handle pipe
② Handle pipe holder
③ Steering stem nut
④ Steering stem washer
⑤ Fork top bridge
⑥ Steering head top thread
⑦ Steering top cone race
⑧ Steel ball
⑨ Steering top ball race
⑩ Steering head
⑪ Steering stem
⑫ Steering bottom ball race
⑬ Steel ball
⑭ Steering bottom cone race
⑮ Steering head dust seal



Fig. 11-3 ① Upper handle holders
② Handle bar

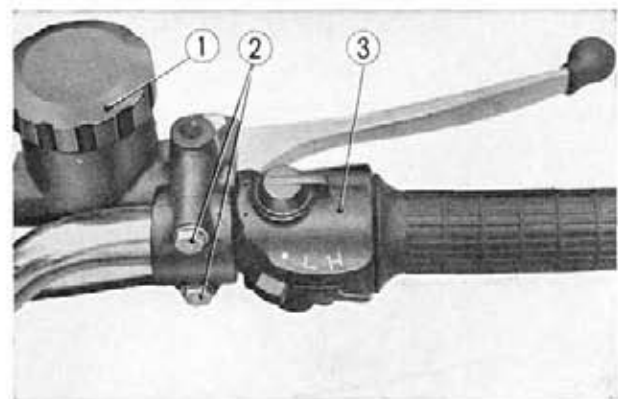


Fig. 11-2 ① Master cylinder body
② Cylinder body mounting bolts
③ Starter lighting ignition switch

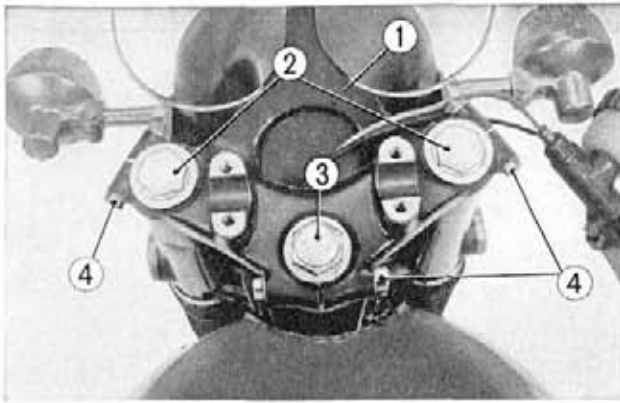


Fig. 11-4 ① Fork top bridge ③ Stem nut
② Front fork top bolts ④ 8mm setting bolts

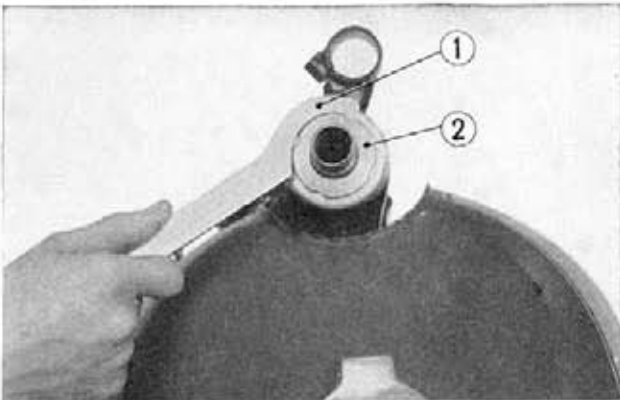


Fig. 11-5 ① Steering stem thread wrench
② Steering stem thread

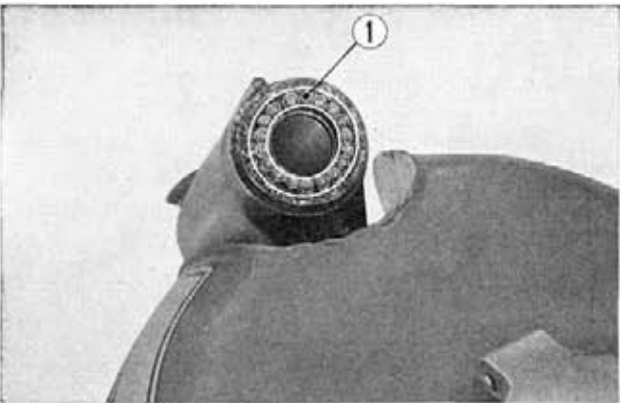


Fig. 11-6 ① Steel balls

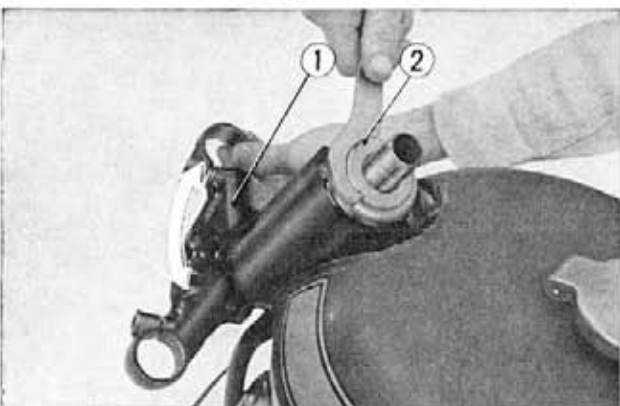


Fig. 11-7 ① Steering stem
② Steering stem thread

5. Loosen the speedometer/tachometer holding clamp and remove the speedometer/tachometer from the fork top bridge.
6. Loosen the stem nut, two front fork top bolts, three 8mm setting bolts and then remove the fork top bridge. (Fig. 11-4)
7. Place a support block under the engine to raise the front wheel off the ground and remove the front suspension in accordance with section 11-3 b. on page 120.
8. Remove the steering stem thread. Work can be facilitated by using the special wrench (Tool No. 07902-2000000). (Fig. 11-5)
9. Pull the steering stem out the bottom, exercising care not to lose the steel balls.

c. Inspection

1. Check the steering handle bar for damage and distortion.
2. Check the steering stem for distortion or cracks.
3. Check to make sure that there is adequate grease in the cone race and also check the steel balls and if found to be excessively worn, they should be replaced.

d. Reassembly

1. Apply a liberal amount of grease on the steering ball races and assemble the steel balls 18 on the upper side and 19 on the lower side. (Fig. 11-6)
2. Exercise care installing the steering stem into the head pipe so that the steel balls are not dropped. Install the top cone race and then screw on the steering stem thread so that there is no clearance between the steering stem and the head pipe in the vertical direction and that the handle turns lightly through the full range of travel. (Fig. 11-7)
3. Assemble the front fork in accordance with 11-3 d on page 121~122.

4. Install the front fork bridge, the stem nut, the two front fork bolts and then fix in place with three 8 mm bolts.
5. Install the speedo/tachometer unit and attach the drive cables.
6. Set the handle bar on the handle holder and mount in place with the upper handle holders.

Position the handle bar by aligning the punch marks on the handle bar to the upper surface of the handle holder. (Fig. 11-8)

7. Connect the electrical wires within the headlight case by matching the same colored wires.
8. Connect the throttle cable to the throttle grip pipe and then mount the throttle grip bracket on the handle. Install the lower bracket by positioning the dowel pin into the hole in the handle bar.
9. Connect the clutch cable to the clutch lever and mount the master cylinder bracket on the handle bar. The cables, wire harness and brake hose should be routed as shown in Fig. 11-9.

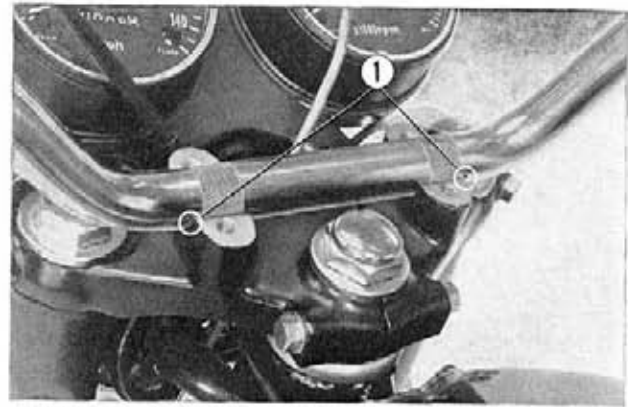


Fig. 11-8 ① Punch marks

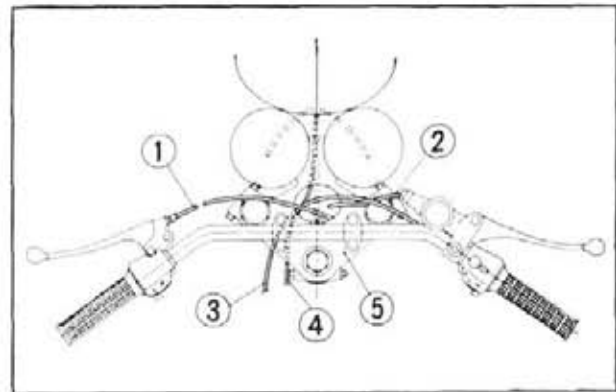


Fig. 11-9

- | | |
|--------------------|-------------------|
| ① Clutch cable | ④ Wire harness |
| ② Front brake hose | ⑤ Fork top bridge |
| ③ Throttle cable | |

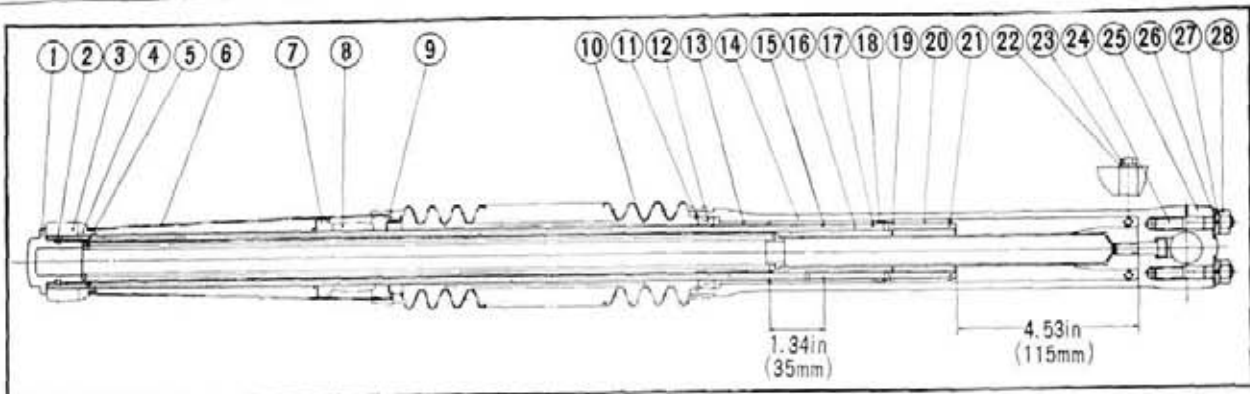
11-3 FRONT SUSPENSION

Piston type

a. Description

The front suspension is a telescoping oil damper type with an aluminum front fork bottom case used for lightness. (Fig. 11-10)

It consists mainly of a fork pipe ① complete with piston ④, a fork bottom case ③ and a cushion spring. On "compression", that is, when any downward load is imposed on the front fork, for example, under heavy front braking, the piston moves down, compressing the oil in chamber "A", and forcing it into chamber "B" through orifices "a" in the periphery of the fork pipe to lift damper valve ⑤ off its seat. On the other hand, the cushion spring, now compressed, exerts an upward reaction to move up the piston. The piston when so moved compresses the oil in chamber "B" and forces it back into chamber "A" through orifice "b" to provide damping action. On "full bump", or bump overcoming the capacity of the cushion spring, the pipe is moved down toward the bottom end of the bottom case, trapping the oil in the space between the pipe and tapered lock piece ⑥ to provide maximum damping. On "full rebound", the orifice "b" is covered by guide ③ and the oil is trapped within chamber "B" to provide damping on the extension side.



- | | | |
|----------------------------|---------------------------|-------------------------|
| ① Front fork bolt | ⑪ 47 mm circlip | ⑳ Fork piston snap ring |
| ② 23×2.8 "O" ring | ⑫ 354611 oil seal | ㉑ Drain cock packing |
| ③ Fork top bridge | ⑬ Front fork pipe guide | ㉒ 6 mm hex bolt |
| ④ Fork cover upper cushion | ⑭ Front fork bottom case | ㉓ 8 mm stud bolt |
| ⑤ Front cushion spring | ⑮ Fork pipe stopper ring | ㉔ 8 mm flat washer |
| ⑥ Front fork cover | ⑯ Front fork pipe | ㉕ Front axle holder |
| ⑦ Fork cover lower cushion | ⑰ Fork valve stopper ring | ㉖ 8 mm spring washer |
| ⑧ Steering stem | ⑱ Front damper valve | ㉗ 8 mm hex nut |
| ⑨ Front fork rib | ㉘ Piston stopper ring | |
| ⑩ Front fork boot | ㉙ Front fork piston | |

Fig. 11-10

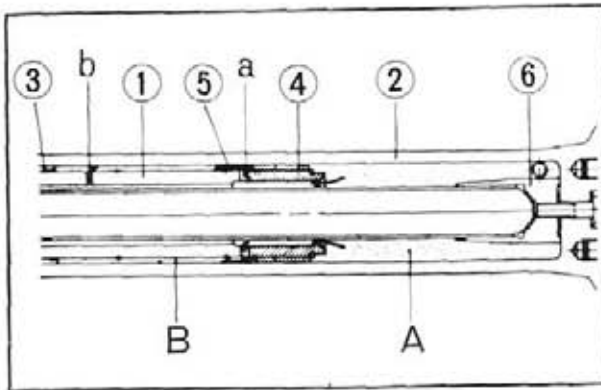


Fig. 11-10-1

- ① Front fork pipe complete
- ② Front fork bottom Case complete

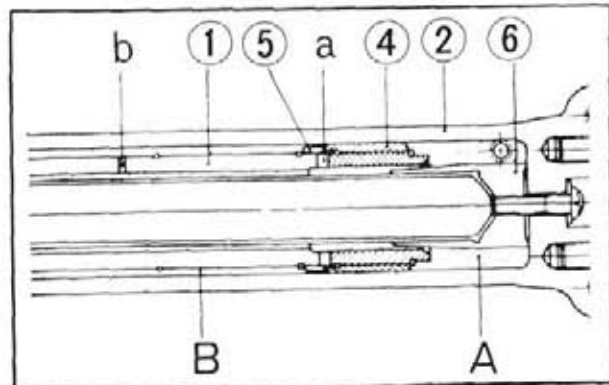


Fig. 11-10-2

- ③ Front fork pipe guide
- ④ Front fork piston
- ⑤ Front damper valve
- ⑥ Oil lock piece

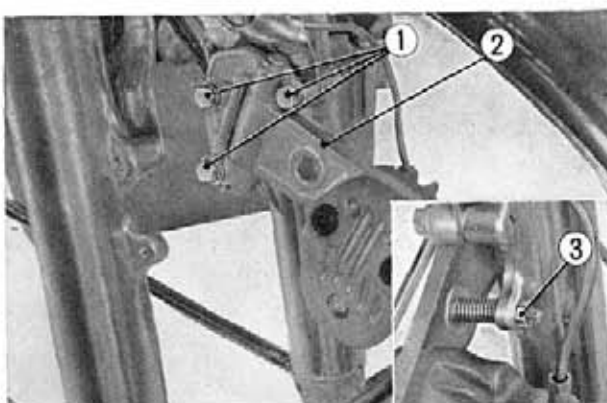


Fig. 11-11 ① Caliper setting bolts
② Caliper assembly ③ Adjuster nut

b. Disassembly

1. Remove the front wheel in accordance with section 13-1b. on page 132~133.
2. Remove the three caliper setting bolts and adjuster nut, and separate the caliper from the left front fork. (Fig. 11-11)
3. Loosen the 8×56 mm front fork pipe mounting bolts (located on the fork top bridge) and the 10×40 mm front fork pipe mounting bolts (located on the steering stem). Pull the front fork gently out the bottom. (Fig. 11-12)

4. Disassemble the front fork by removing the internal circlip with a circlip pliers and separating the front fork pipe from the bottom case (Fig. 11-13).
5. By removing the fork piston snap ring, the front fork piston and the front fork damper valve may be disassembled from the front fork pipe. (Fig. 11-14)

c. Inspection

1. Checking front fork oil

To maintain good riding characteristics and increase fork service life, the oil in the front fork should be changed periodically.

Unscrew the front fork drain plug at the bottom of the fork cylinder, drain the oil by pumping the forks while plug is out. Replace the plug securely after draining. (Fig. 11-15)

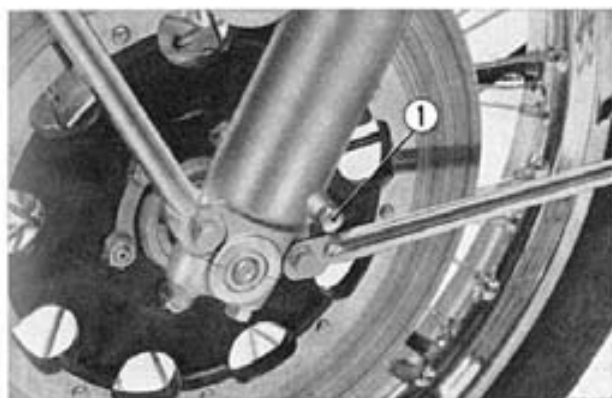


Fig. 11-15 ① Front fork drain plug

Remove the top filler plug and fill the front fork cylinder with 7.0~7.3 ozs. (220~230 cc) of **premium quality oil of SAE 10 W-30 grade.** (Fig. 11-16)

Securely tighten the top filler plug after filling.

2. Check the front fork assembly by locking the front brake and pumping the fork up and down vigorously.
 - Smooth cushion action.
 - Oil seepage around the cushion oil seals.

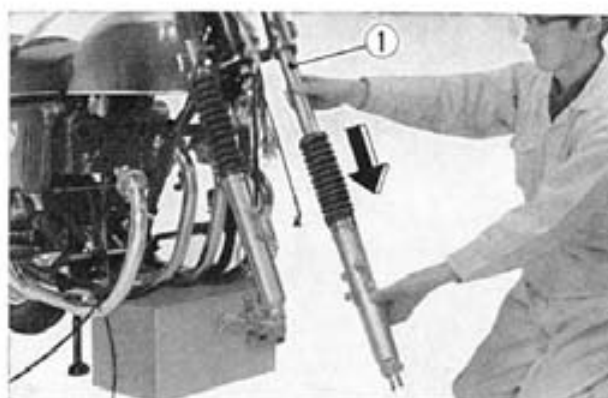


Fig. 11-12 ① Front fork

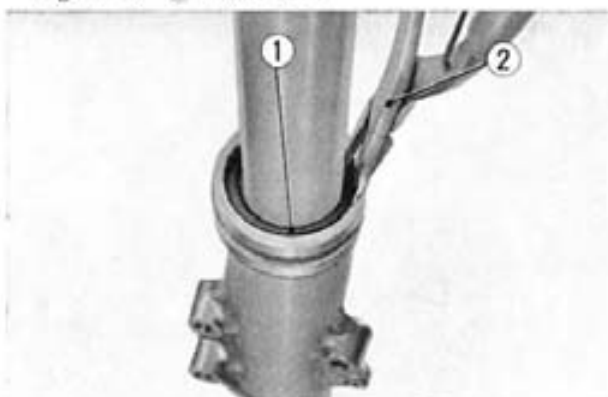


Fig. 11-13 ① Internal circlip ② Pliers

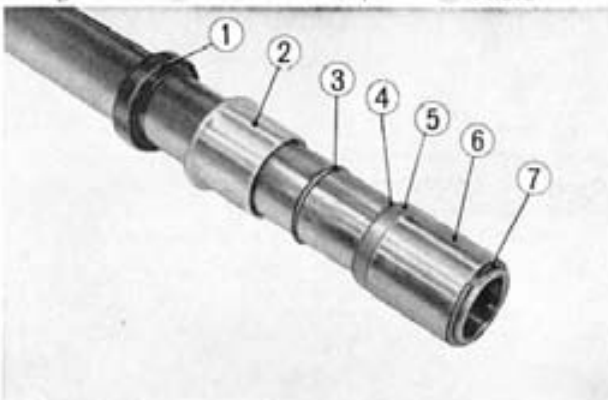


Fig. 11-14
 ① 354611 oil seal ⑤ Front damper valve
 ② Front fork pipe guide ⑥ Front fork piston
 ③ Fork pipe stopper ring ⑦ Fork piston snap ring
 ④ Fork valve stopper ring

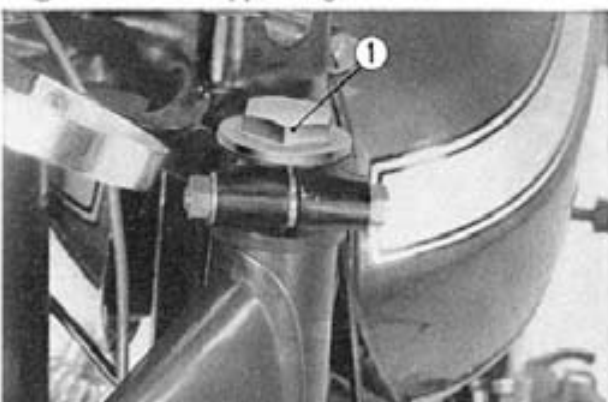


Fig. 11-16 ① Top filler plug

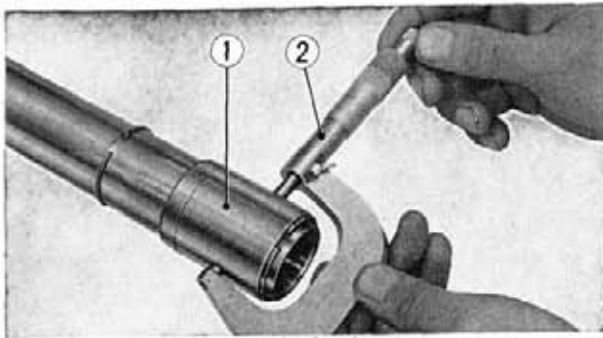


Fig. 11-17 ① Front fork piston
② Micrometer

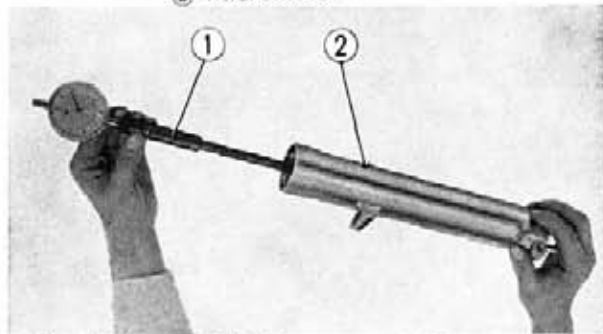


Fig. 11-18 ① Cylinder gauge ② Bottom case

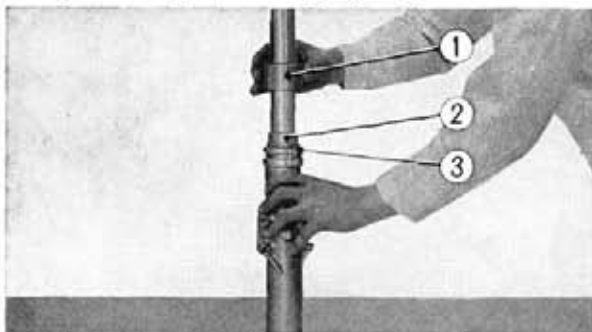


Fig. 11-19 ① Oil seal driving weight
② Oil seal driving guide
③ Oil seal



Fig. 11-20 ① Front fork assembling bar
② Front fork pipe setting bolt (8 mm)
③ Front fork pipe setting bolt (10 mm)

3. Measure the diameter of the front fork piston. Use a micrometer to perform this check and if it is found to be less than 1.551 in. (39.4 mm), the piston should be replaced. (Fig. 11-17)
4. Measure the inner diameter of the front fork bottom case. Use a cylinder gauge to perform this check and if it is found to be over than 1.562 in (39.68 mm), the front fork bottom case should be replaced. (Fig. 11-18)

d. Reassembly

1. Wash all the parts and then assemble the pipe guide, stopper rings, damper valve, piston and snap ring in that order on the front fork pipe. (Fig. 11-14)
2. Assemble the front fork pipe into the front fork bottom case and install the oil seal using the oil seal guide (Tool No. 07947-3290000). (Fig. 11-19)

Exercise care that the oil seal is not damaged during installations and install the circlip into the groove in the bottom case.

Note: To disassemble the front forks of motorcycles from Frame No. 1044650 to 2089878, proceed as follows:

- Replace the oil seals with new ones (double lip type) (Part No. 91255-341-305).

Replacement

- The employment of new oil seals abolished higherto used back-up rings due to the change in seal width.
 - Apply a coat of oil to the seals and insert them from the piston side while rotating.
3. Install the front fork upper cover on the steering stem (above and below the cushion rubbers) and insert the front fork pipe assembly through the steering stem, and temporarily tighten with the 10mm front fork setting bolt. (Fig. 11-20)
 4. Fill the front fork cylinder with 7.0~7.3 ozs (220~230 cc) of premium quality oil of SAE 10W-30 grade, and securely tighten the top filler plug after filling.
 5. Properly tighten the front fork pipe setting bolts (8, 10 mm).
 6. Adjust the front brake caliper by referring to page 147~148.

REAR SUSPENSION

GROUP

12

CONTENTS

| | |
|--|-----|
| 12-1 GENERAL DESCRIPTION | 123 |
| DESCRIPTION | 123 |
| SPECIFICATIONS | 123 |
| DIAGNOSIS | 124 |
| 12-2 REAR SHOCK ABSORBERS | 124 |
| a. Description | 124 |
| b. Disassembly | 125 |
| c. Inspection | 125 |
| d. Reassembly | 125 |
| 12-3 REAR FORK | 127 |
| a. Description | 127 |
| b. Disassembly | 127 |
| c. Inspection | 127 |
| d. Reassembly | 128 |

12-1 GENERAL DESCRIPTION

DESCRIPTIONS

The suspensions must not only absorb the vertical shock caused from the road conditions but must also be able to sustain applied force resulting from steering function. The rear suspension mechanism consists of the rear cushion and rear fork.

SPECIFICATIONS

| Item | Standard value | Serviceable limit |
|-----------------------|------------------------------------|-------------------|
| Rear cushion spring | | |
| Spring inner diameter | 1.401~1.429 in. 35.7~36.3 mm | — |
| Free length | 8.74 in. 222 mm | 8.504 in. 216 mm |
| Coil diameter | 0.276 in. 7 mm | — |
| Installation load | 8.17 in./66.6 lbs 207.5 mm/30.2 kg | — |
| Tilt | within 1.5° | Over 2.5° |

| Item | Standard value | Serviceable limit |
|------------------------------|------------------------------------|--------------------|
| Rear fork | | |
| Pivot bush inner diameter | 0.8426~0.8447 in. 21.403~21.455 mm | 0.8504 in. 21.6 mm |
| Center collar outer diameter | 0.8412~0.8425 in. 21.367~21.400 mm | 0.8386 in. 21.3 mm |

DIAGNOSIS

| Trouble | Probable Causes | Remedy |
|------------------|---|---|
| Soft suspension | 1. Loss of spring tension 2. Excessive load | Replace |
| Hard suspension | 1. Ineffective front cushion damper 2. Ineffective rear cushion damper | Replace Replace |
| Suspension noise | 1. Cushion case rubbing 2. Interference between cushion case and spring 3. Damaged cushion stopper rubber 4. Insufficient spring damper oil (front and rear) | Inspect cushion spring and case Repair Replace Replace |

12-2 REAR SHOCK ABSORBERS

a. Description

The rear suspension is a swing arm type with a large stroke of 3.43 in. (87 mm).

A De Carbon type rear damper is employed on the CB750 is of a single cylinder double acting type. (Fig. 12-1)

This damper is, as shown in the figure below, a double-acting type single cylinder in which nitrogen gas and oil are used to give an optimum damping performance under all bumping and rebounding conditions. Over the damper is installed a dual-pitch spring which absorbs a wide range of vibrations or shocks and maintains the unit in accurate alignment. Another design feature is that the cushion is adjustable for different riding, loading and road conditions.

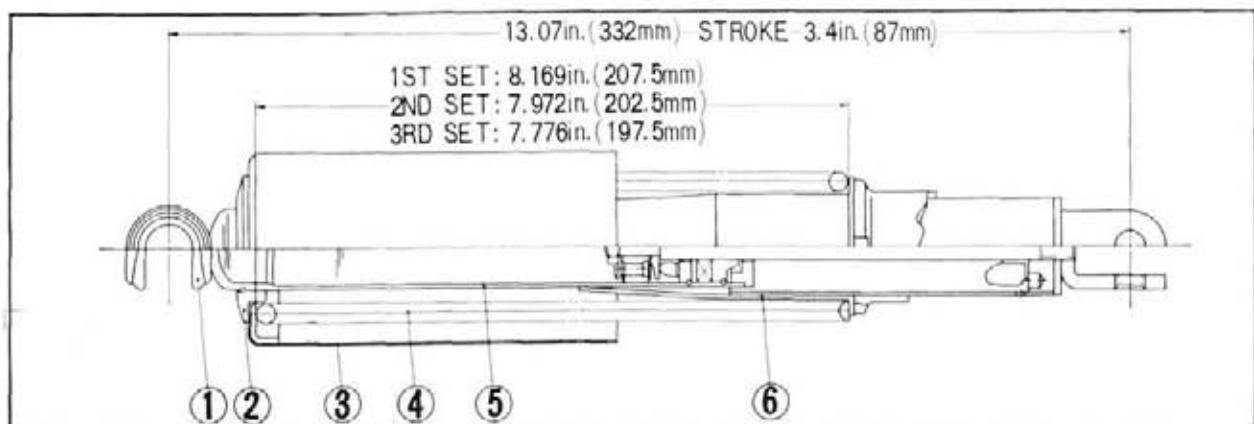


Fig. 12-1

- | | |
|----------------------------|-----------------------------|
| ① Joint rubber | ④ Rear cushion spring |
| ② Spring seat stopper | ⑤ Rear damper assembly |
| ③ Rear cushion upper cover | ⑥ Rear cushion spring guide |

Simple type of a construction the heat radiation is good, therefore, performance being especially good at low speed. Further, vibration stabilizes very quickly.

Air and oil mixture will not occur and function will not be deteriorates even when operated for extended period over adverse road condition.

The difference in pressure between the front and rear of the valve is small; since form does not form, noise is minimized; deterioration of the damping force is prevented. (Fig. 5-61)

The rear cushion employs a dual pitch spring, the section with the larger pitch absorbs the large vibration while the section with the smaller pitch absorbs the smaller vibration. This provides for exceptionally smooth riding. Further, there are three ranges of adjustment incorporated in the rear cushion, making it possible to adjust the cushion to the different riding, loading and road conditions.

b. Disassembly

1. Unscrew the rear cushion cap nut and bolt, and remove the rear cushion from the frame. (Fig. 12-2)
2. Remove the rear cushion spring using the rear cushion disassembling tool (Tool No. 07959-3290000). (Fig. 12-3)

Note: The rear cushion contains nitrogen gas under high pressure, therefore, disassembly should not be attempted because possible injury may result.

c. Inspection

1. Rear cushion spring free length
Measure the free length of the rear cushion spring using a vernier caliper, if it is under 18.11 in. (460 mm), the spring should be replaced with a new part. (Fig. 12-4)

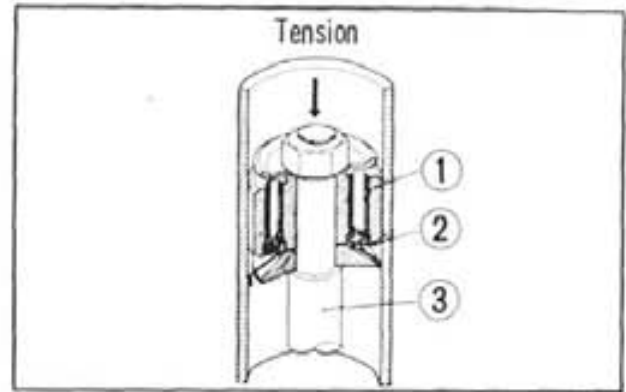


Fig. 12-1-1 ① Piston ② Valve ③ Rod

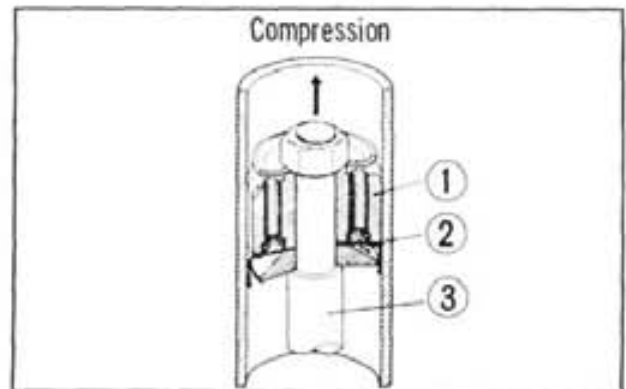


Fig. 12-1-2 ① Piston ② Valve ③ Rod

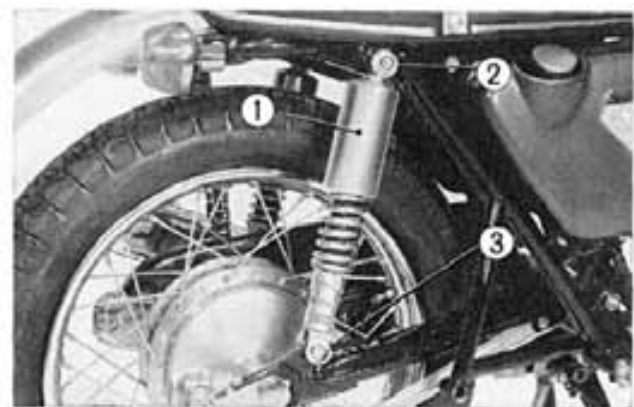


Fig. 12-2 ① Rear cushion ② Cap nut ③ Setting bolt

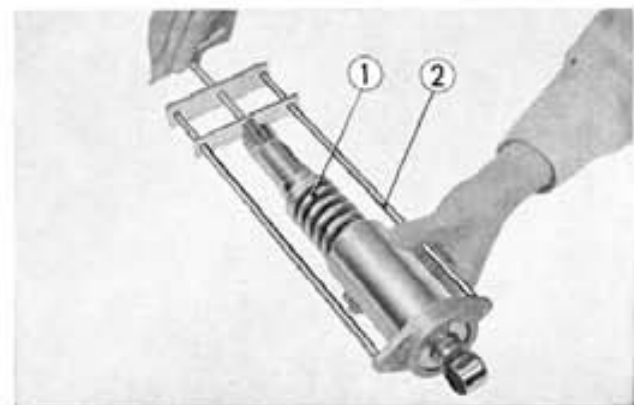


Fig. 12-3 ① Rear cushion spring ② Rear cushion disassembling tool

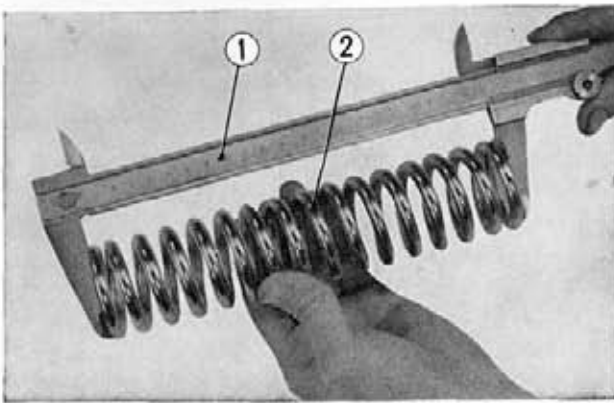


Fig. 12-4 ① Vernier caliper
② Rear cushion spring

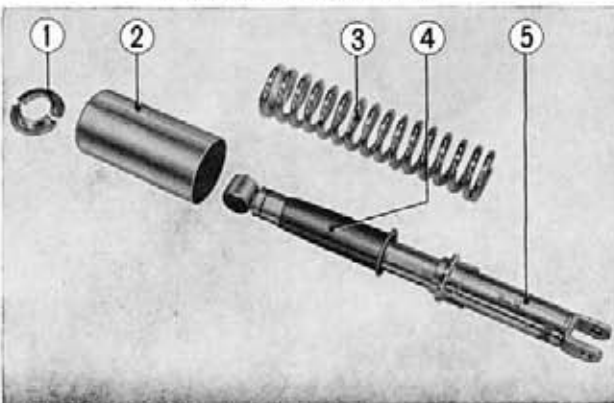


Fig. 12-5 ① Spring seat stopper
② Rear cushion upper case ③ Rear cushion spring
④ Rear cushion spring guide ⑤ Rear damper unit

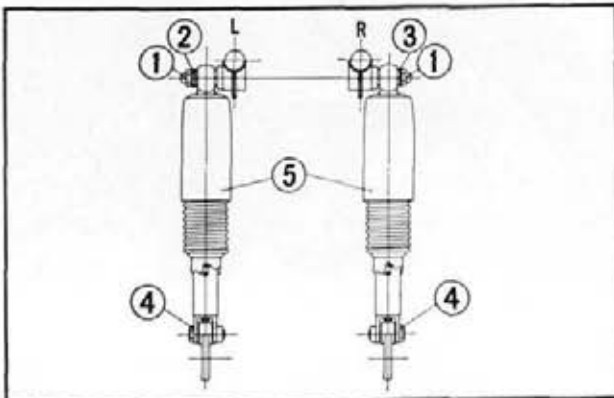


Fig. 12-6 ① 10mm cap nuts ④ 10mm bolts
② Side grip ⑤ Rear cushions
③ Washer

2. Rear cushion spring trueness

Set the spring up on its end on the surface gauge and measure the amount of tilt with a square and vernier caliper.

If the tilt is over 2.5° , the rear cushion should be replaced.

3. Inspect the cushion damper to insure that there is no fluid leakage.
4. Inspect the damper case and rod to insure that they are not damped or deformed.
5. Inspect the rear cushion stopper to insure that it is not damaged or deformed.

d. Reassembly

1. Assemble the under seat, spring and upper case to the damper. Compress the assembly using a rear cushion assembly tool (Tool No. 07959-3290000) and lock the assembly with spring seat stopper. (Fig. 12-5)

Note: Upon completing the assembly, actuate the cushion assembly by hand to make sure that they are not binding.

2. Mount the rear cushion on the frame with the rear cushion cap nut and bolt.

Note: After installing the cushion, check the alignment of the right and left cushion and also the alignment of the cushion mounting bolt for both right and left sides (Fig. 12-6).

12-3 REAR FORK

a. Description

The rear fork has a rectangular cross section made from pressed steel plate to provide greater rigidity at the wheel mounting which is a clamp design.

One end of the rear fork is fitted to a section on the frame and the other end is fitted to the frame through the rear cushion. When the rear wheel moves in the vertical direction, the section which is fitted to the frame becomes the pivot point and the rear wheel moves in an arc.

The close proximity of the pivot point to the drive sprocket poses negligible effect on the chain tension.

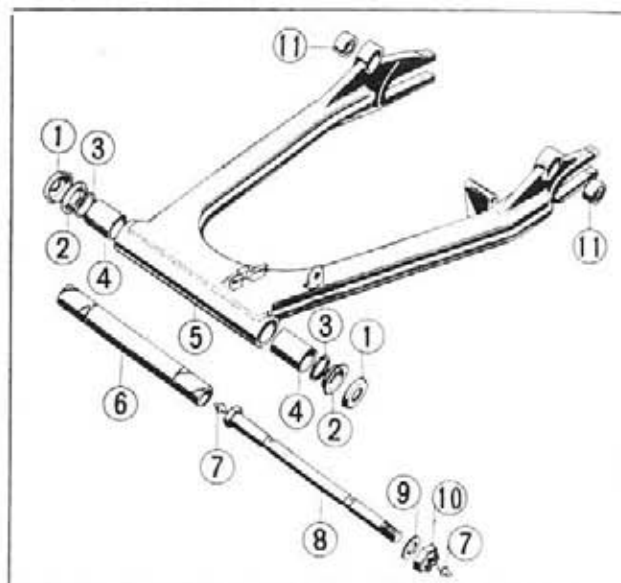


Fig. 12-7

| | |
|---------------------------|----------------------------------|
| ① Dust seal cap | ⑦ Grease nipple |
| ② Pivot thrust bush | ⑧ Rear fork pivot bolt |
| ③ Rear fork felt ring | ⑨ Rear fork pivot bolt washer |
| ④ Rear fork pivot bush | ⑩ 14mm self lock nut |
| ⑤ Rear fork | ⑪ Rear cushion under rubber bush |
| ⑥ Rear fork center collar | |

b. Disassembly

1. The exhaust mufflers must first be removed before the rear fork can be removed.
2. Remove the cotter pin from the rear wheel axle, loosen the axle nut and remove the drive chain.
3. Unscrew the rear brake adjuster nut, the rear brake torque bolt and remove the axle to separate the rear wheel. (refer to page 137)
4. Unscrew the rear fork pivot nut and bolt, and then separate the rear fork from the frame. The rear fork side washer and the pivot collar can be removed. (Fig. 12-8)

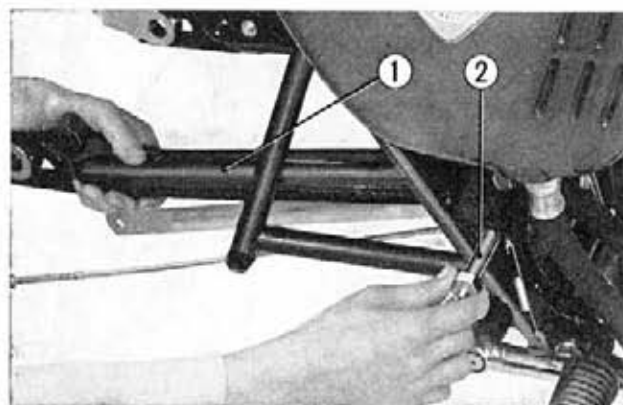


Fig. 12-8

| |
|------------------------|
| ① Rear fork |
| ② Rear fork pivot bolt |

c. Inspection

1. Visually check the rear fork for bend and distortion, and if found to be excessive, it should be replaced with a new part.
2. Scratched and deformed part should be either repaired or replaced.
3. Measure the bores of the rear fork pivot bushing with a inner dial gauge and the outside diameter of the center collar with micrometer, and if they are not within the serviceable limit shown below, they should be replaced. (Fig. 12-9)

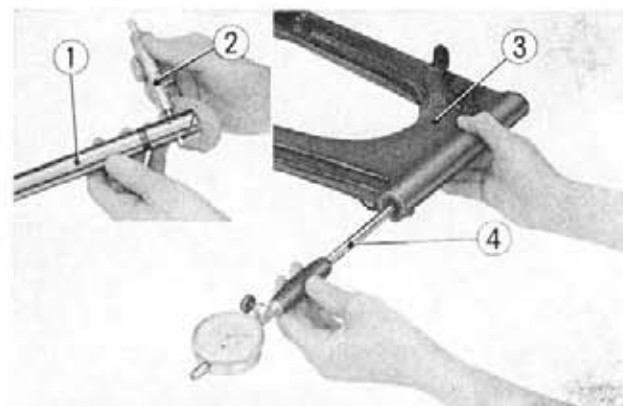


Fig. 12-9

| |
|--------------------|
| ① Center collar |
| ② Micrometer |
| ③ Rear fork |
| ④ Inner dial gauge |



| Item | Serviceable limit |
|---|----------------------|
| Rear fork pivot bush inner diameter | 0.858 in. (21.8 mm) |
| Rear fork center collar outer diameter | 0.8452 in. (21.4 mm) |

4. There are two lubrication points as shown in the Fig. 19-18. It is recommended that lubrication be performed in accordance with section 19 on page 185.

d. Reassembly

1. Apply a liberal amount of grease on the pivot collar and assemble it into the rear fork. Insert the pivot bolt from the right side while holding the dust seal caps on both sides of the rear fork, and then install and tighten the 14 mm self lock nut.
2. Install the rear wheel.
3. Install the drive chain.
4. When the assembly is completed, adjust the rear brake pedal and drive chain tension. (refer to page 149 and 186)

WHEELS, TIRES AND FINAL DRIVE

GROUP
13

CONTENTS

| | |
|--|-----|
| 13-1 GENERAL DESCRIPTION | 129 |
| DESCRIPTION | 129 |
| SPECIFICATIONS | 130 |
| DIAGNOSIS | 130 |
| 13-2 FRONT WHEEL AND TIRE | 131 |
| a. Description | 131 |
| b. Disassembly | 132 |
| c. Inspection | 133 |
| d. Reassembly | 133 |
| 13-3 REAR WHEEL AND TIRE | 135 |
| a. Description | 135 |
| b. Disassembly | 137 |
| c. Inspection | 138 |
| d. Reassembly | 138 |
| 13-4 FINAL DRIVE | 139 |
| a. Description | 139 |
| b. Disassembly | 139 |
| c. Inspection | 139 |
| d. Reassembly | 139 |

13-1 GENERAL DESCRIPTION

DESCRIPTION

Carefully check to make sure that the front and rear wheels are properly aligned and both tires have specified air pressure.

If these are not properly maintained, it will be dangerous, especially when riding at a high speed.



SPECIFICATIONS

| Item | Standard value | | Serviceable limit | |
|-------------------------------------|-----------------------------------|-------------------------|---------------------|-----------------------|
| Rim runout | Within | 0.02 in. 0.5 mm | Over | 0.08 in. 2.0 mm |
| Ball bearing diametrical runout (F) | Within | 0.00012 in. 0.003 mm | Over | 0.002 in. 0.05 mm |
| " (R) | Within | 0.0002 in. 0.005 mm | Over | 0.0024 in. 0.06 mm |
| Ball bearing axial runout | Within | 0.0028 in. 0.07 mm | Over | 0.004 in. 0.1 mm |
| Rear brake lining | 7.0787~7.0866 in. 179.8~180 mm | | 7.205 in. 183 mm | |
| Rear brake shoe thickness | 0.197 in. 5.0 mm | | 0.08 in. 2.0 mm | |

DIAGNOSIS

| Trouble | Probable Causes | Remedy |
|-----------------------------|--|---|
| Heavy steering | Low tire pressure | Add air to the specified tire pressure 28.5 lbs/in ² /(2 kg/cm ²) |
| Front and rear wheel wobble | <ol style="list-style-type: none"> 1. Worn front and rear wheel bearings. 2. Front or rear wheel runout of distorted. 3. Loose spoke. 4. Defective tire. | Replace bearing Repair or replace. Retorque. Replace. |

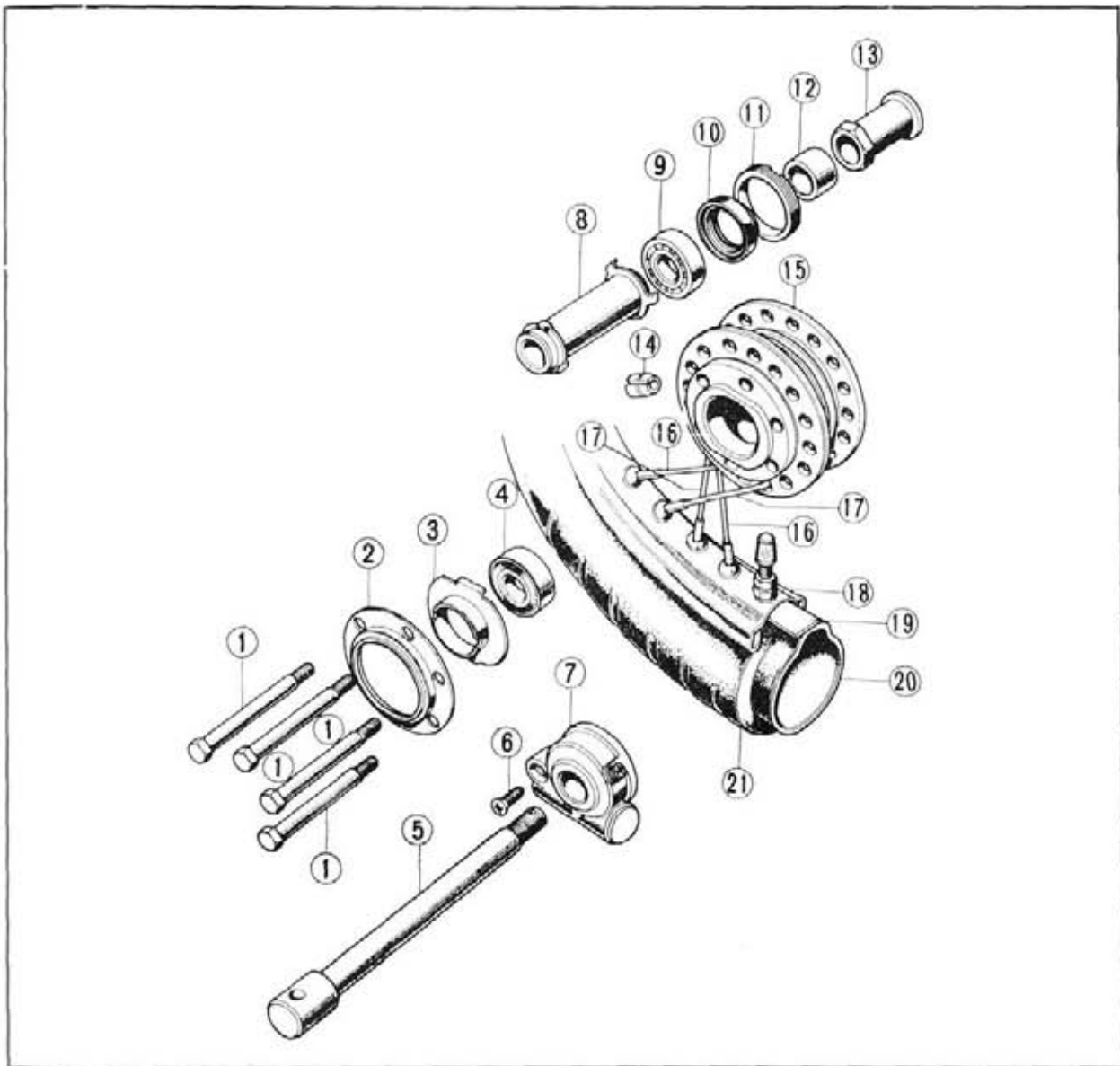
13-2 FRONT WHEEL AND TIRE

a. Description

For the front wheel, large size tire, 3.25-19, is used to provide a greater safety factor and a comfortable riding.

The cast aluminum hub houses the front brake disc, two 6302 Z ball bearings, front axle distance collar, dust seal and bearing retainer.

The Fig. 13-1 shows the front wheel component parts.



- ① 8×10 mm bolt
- ② Gear box retainer cover
- ③ Gear box retainer
- ④ 6302 Z ball bearing
- ⑤ Front wheel axle
- ⑥ 5×15 mm oval screw
- ⑦ Speedometer gear box

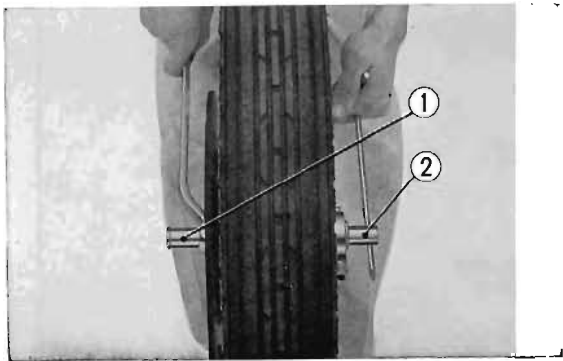
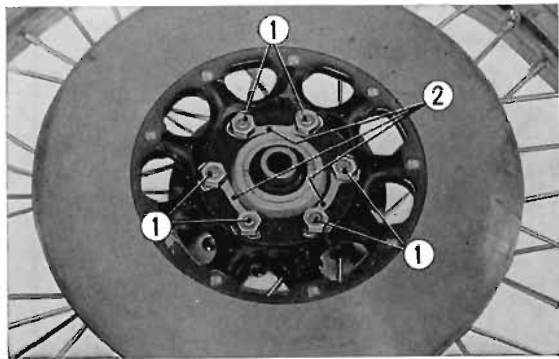
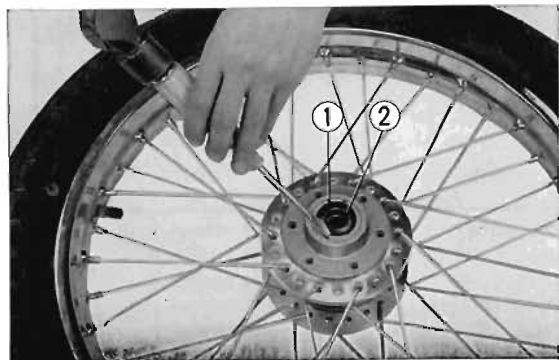
- ⑧ Front axle distance collar
- ⑨ 6302 Z ball bearing
- ⑩ 22368 dust seal
- ⑪ Front wheel bearing retainer
- ⑫ Front wheel collar
- ⑬ Front wheel axle nut
- ⑭ Wheel balancer

- ⑮ Front wheel hub
- ⑯ Front spoke A
- ⑰ Front spoke B
- ⑱ Front wheel rim
- ⑲ Front tire flap
- ⑳ Front wheel tube
- ㉑ Front wheel tire

Fig. 13-1



Fig. 13-2 ① Speedometer cable

Fig. 13-3 ① Front axle nut
② Front axleFig. 13-4 ① Disc setting bolts & nuts
② Tongued washersFig. 13-5 ① Front wheel bearing retainer
② Dust seal

b. Disassembly

1. Raise the front wheel off the ground by placing a support under the engine.
2. Remove the speedometer cable from the front wheel hub assembly. (Fig. 13-2)
3. Remove the axle holder fixing nuts and the front wheel assembly can be removed from the front fork.

Note: Do not depress the brake lever when the wheel is off the motorcycle as this can cause the caliper piston to be forced out of the cylinder with subsequent loss of hydraulic fluid. If this does occur servicing of the brake system will be necessary (see page 40~41).

4. Unscrew the front wheel axle nut and remove the front axle. (Fig. 13-3)
5. Remove the speedometer gear box.
6. Unlock the tongued washers, loosen the nuts and then remove the disc from the wheel. (Fig. 13-4)

Remove the gear box retainer cover, and remove the gear box retainer from the opposite side.

7. Remove the front wheel bearing retainer from the wheel hub and remove the dust seal from the front wheel bearing retainer. (Fig. 13-5).
8. Remove the front wheel bearing.
9. Remove the tire in accordance with following manner.
 - a. Lay wheel assembly on a rag or cardboard to prevent hub surface damage.
 - b. Remove valve core and valve stem retaining nut. Locate and remove any sharp object if the cause of puncture.
 - c. Step down on tire to break it free from the rim. Repeat on the opposite side.
 - d. Using two small or medium size irons, placed 4-6 in. apart and inserted between the rim edge and tire bead at the valve stem location, pry in and downward with both tire irons while depressing the tire bead opposite the tire irons, with your-foot. When tire bead is above the rim edge remove only on tire iron and move it 3-4 in. further away from the tire iron supporting the tire bead and insert and pry the tire bead further off of the rim. Pro-

ceed in this manner until the entire side of the tire casing is above and clear of the rim edge.

- e. The deflated inner tube can now be pulled from the tire casing and the inner tire casing inspected for damage or protruding sharp object etc. Locate and eliminate cause of flat or puncture.

c. Inspection

1. Check the flatness of front brake disc.
Place the disc on the surface plate and measure the flatness using the dial gauge. If the difference is greater than **0.012 in. (0.3 mm)**, the disc should be replaced with a new part. Further, the disc should also be changed if the thickness of the disc is less than **0.217 in. (5.5 mm)**. (Fig. 13-6)

2. Checking the rim runout

Pass a shaft through the front wheel and spin the wheel by hand, and read the runout at the rim using a dial gauge. If the runout is greater than **0.080 in. (2.0 mm)**, the rim should be either repaired or replaced. (Fig. 13-7)

3. Wheel ball bearing

Measure the axial and diametrical runout of the ball bearing with a dial gauge. If the value is over serviceable limit listed below the ball bearing should be replaced. (Fig. 13-8)

| Item | Serviceable limit |
|--------------------|--------------------|
| Axial runout | 0.004 in (0.1 mm) |
| Diametrical runout | 0.002 in (0.05 mm) |

d. Reassembly

1. Install the tire in accordance with following manner.
 - a. Install a new inner tube of the correct size by inflating very slightly, leave the valve core in the valve stem.
 - b. Inspect the wheel rim strip inner tube protector to see that it is in good condition and centered over the spoke nipples in the rim recess.
 - c. Align the tire balance mark with the valve stem hole in the rim and insert the partially inflated inner tube into the tire casing. With the valve stem aligned with the valve stem hole in the rim.
 - d. Work the inner tube into proper position in the tire casing and insert the valve stem through the valve stem hole in the rim. Install a valve stem retaining nut partially on to the valve stem. (1/4-1/2 in. do not tighten.) Remove valve core.
 - e. Apply a light coating of tire mounting solution (liquid detergent can be used in an emergency) to each of the tire bead surfaces and between the free tire bead and rim edge.
 - f. The tire can now be stepped into place using your heels. Placing both heels on the tire bead opposite the valve core and depressing the tire bead into place a slight amount with each step in opposite directions around the wheel.
 - g. When 80~90% of the tire bead is in place, use a tire mounting mallet (heavy rub-

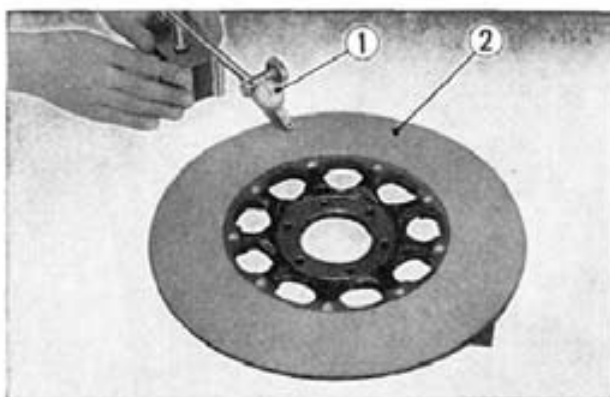


Fig. 13-6 ① Dial gauge
② Front brake disc



Fig. 13-7 ① Dial gauge

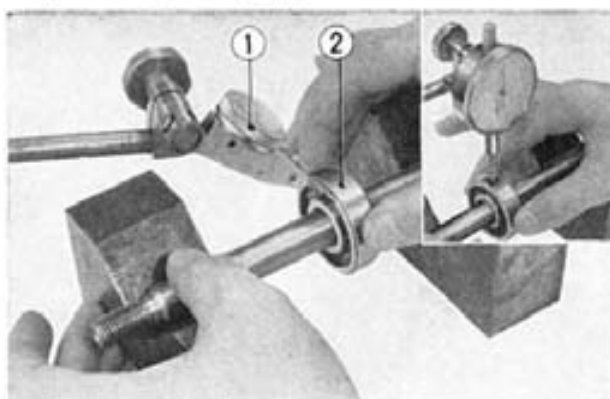


Fig. 13-8 ① Dial gauge
② Ball bearing

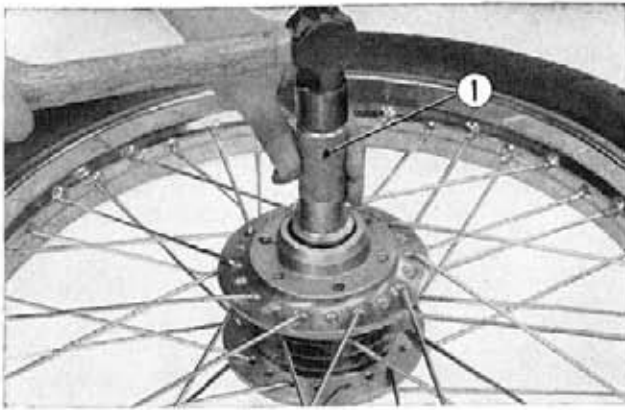


Fig. 13-9 ① Bearing driver

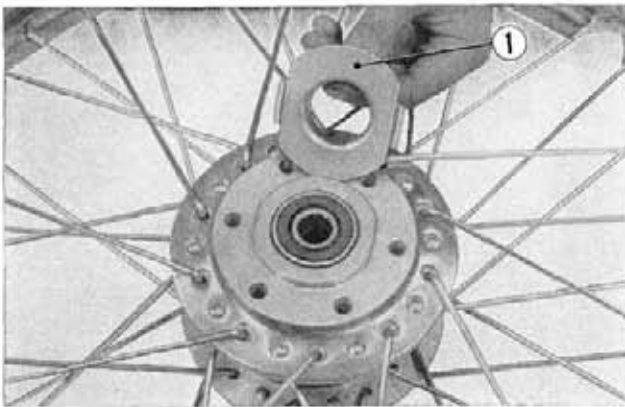


Fig. 13-10 ① Gear box retainer

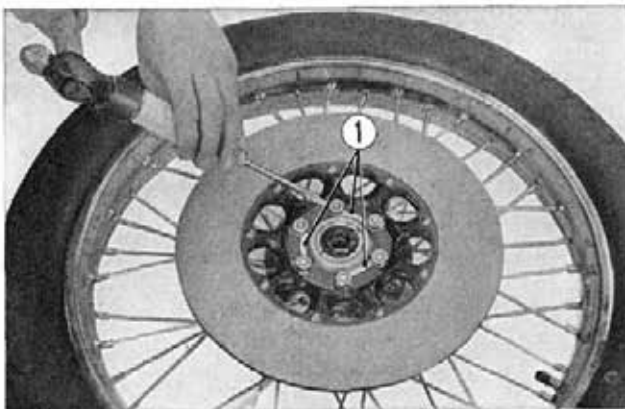
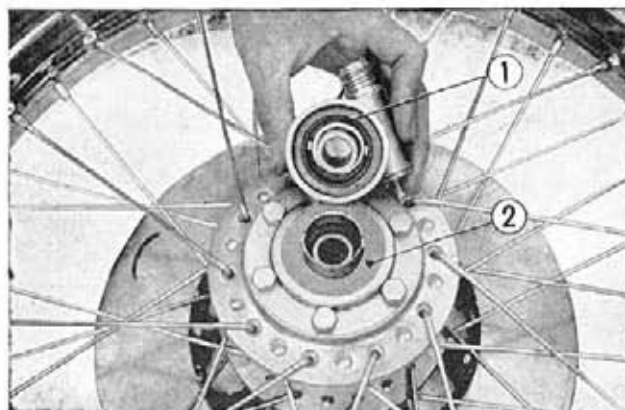


Fig. 13-11 ① Tongued washer

Fig. 13-12 ① Speedometer gear box
② Gear box retainer

ber, leather or plastic hammer) to force the remaining to section into position. Avoid using tire irons or screw drivers for this operation as inner tube punctures will result due to pinching with the tool.

- h. Insert the valve core and over inflate the standard pressure by approximately 10 psi. This will help to properly seat the tire beads into the rim. Inspect for proper tire bead seating and deflate the tire. Reinflate to the correct specified pressure 28.5 lb/in² (2.0 kg/cm²), and tighten the valve stem retaining nut lightly.
 - i. Recheck the tire pressure and install the valve stem cap.
2. Drive the wheel bearing into the wheel using a bearing driver (Tool No. 07949~3000100). (Fig. 13-9)
 3. Install the dust seal into the front wheel bearing retainer, mount the front wheel bearing retainer into the wheel hub.
 4. Align the gear box retainer to the cutout in the wheel hub and install the gear box retainer cover from above, and install the six disc mounting bolts. Mount the disc of the opposite side and fix in place with the nuts. (Fig. 13-10)

Note: New tongued washers should be used and the tab on the washers bent up to lock. (Fig. 13-11)

5. Insert the front axle through the speedometer gear box from the right side and tighten the front axle nut. (Fig. 13-12)
6. Mount the front wheel on the front forks and mount the axle holders and tighten the setting nuts.

7. Connect the speedometer cable to the gear box. (Fig. 13-13)



Fig. 13-13 ① Speedometer cable
② Setting screw

8. Balance the wheel (Fig. 13-22)

Perform the balancing in the following manner.

- a. Raise the wheel off the ground and lightly rotate.

Note: If the front wheel does not rotate freely, turn the front brake stopper bolt clockwise until the front wheel rotate freely.

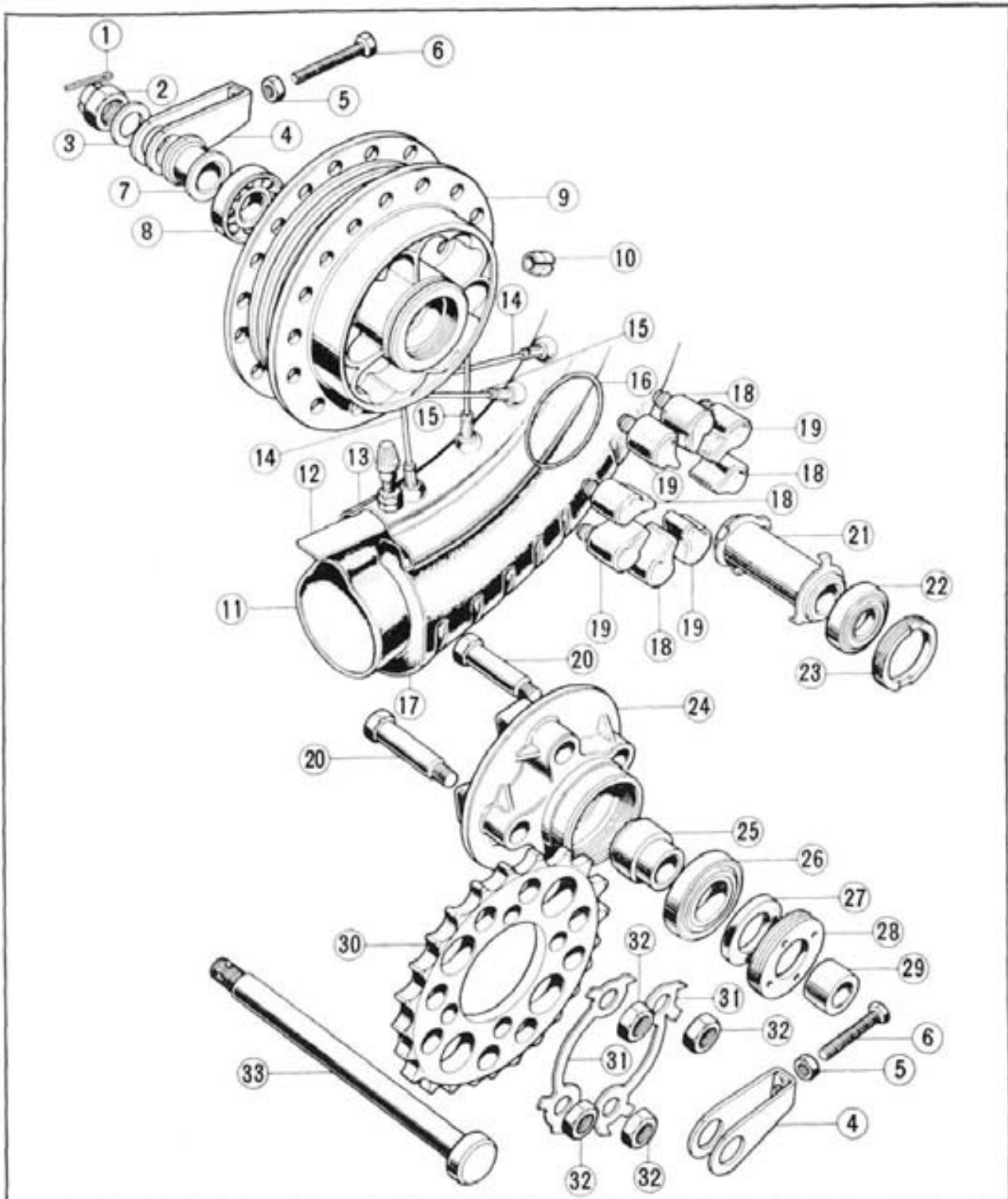
- b. Lightly attach an appropriate weight on the spoke adjacent to the nipple which stop at the highest position. Weights are available in four types, 5 gr, 10 gr, 15 gr and 20 gr.
c. The wheel is in proper balance if the wheel after spinning will come to rest at no definite position.
d. If the wheel does not statically balance, change the weight and reperform items b and c.
e. Lock the weight with pliers after completing the balance.

13-3 REAR WHEEL AND TIRE

a. Description

For the rear wheel, a tire size, 4.00-18, is used to provide a greater safety factor. The wheel consists of an aluminum casting rear wheel hub which contain two 6304 ball bearings, final drive flange and brake panel.

Also, eight rear wheel dampers are mounted in the wheel hub to reduce the vibration or shock from the final driven sprocket. Fig. 13-14 shows the rear wheel component parts.



- ① 4×30 Cotter pin
- ② Rear axle nut
- ③ 18.5×34 washer
- ④ Chain adjuster
- ⑤ 8 mm hex nut
- ⑥ Chain adjusting bolt
- ⑦ Rear brake panel side collar
- ⑧ 6304 ball bearing
- ⑨ Rear wheel hub
- ⑩ Wheel balancer
- ⑪ Rear wheel tube

- ⑫ Rear tire flap
- ⑬ Rear wheel rim
- ⑭ Rear spoke B
- ⑮ Rear spoke A
- ⑯ 68×2.6 "O" ring
- ⑰ Rear wheel tire
- ⑱ Left rear wheel damper
- ⑲ Right rear wheel damper
- ⑳ Driven sprocket fixing bolt
- ㉑ Rear axle distance collar
- ㉒ 6304 ball bearing

- ㉓ Rear wheel bearing retainer
- ㉔ Final drive flange
- ㉕ Rear axle sleeve
- ㉖ 6305 ball bearing
- ㉗ 34×56×9 Oil seal
- ㉘ Rear wheel bearing retainer
- ㉙ Rear wheel side collar
- ㉚ Final driven sprocket
- ㉛ 12 mm tongued washer
- ㉜ 12 mm hex nut
- ㉝ Rear wheel axle

Fig. 13-14

b. Disassembly

1. Place the motorcycle on the main stand.
2. Remove the rear brake adjusting nut and brake rod from the brake arm. (Fig. 13-15)
3. Remove rear brake stopper arm lock pin, nut, flat washer, spring washer and bolt. (Fig. 13-16)
4. Remove the cotter pin from the right side of the rear axle and loosen the axle nut. (Fig. 13-17)
5. Loosen the drive chain adjusting bolt lock nuts, back out the abjuster bolts and turn the chain adjusters downward. Remove the rear fork cap fixing bolts and fork caps. (Fig. 13-17)
6. Push the wheel forward, lift the chain off the sprocket, then pull the wheel rearward, clear of the rear fork.
7. Remove the rear wheel from the frame.
8. Unlock the tongued washers, remove the nuts and the driven sprocket can then be removed. (Fig. 13-18)
9. Remove the rear wheel bearing retainer, and remove the bearing from the wheel hub. (Fig. 13-19)



Fig. 13-15 ① Rear brake arm
② Rear brake adjusting nut

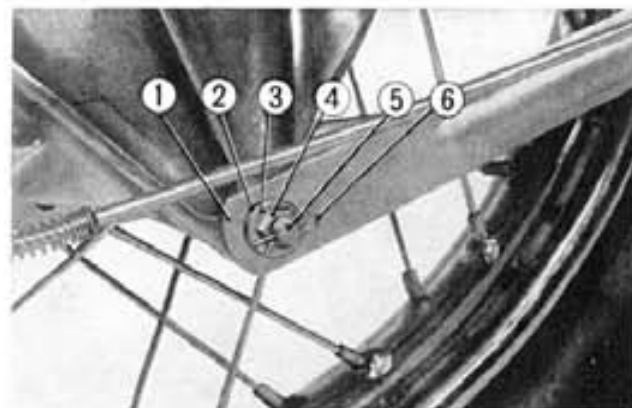


Fig. 13-16 ① Rear brake stopper arm
② 10 mm spring washer
③ 8 mm flat washer
④ 8 mm nut
⑤ Rear brake panel stopper bolt
⑥ Lock pin

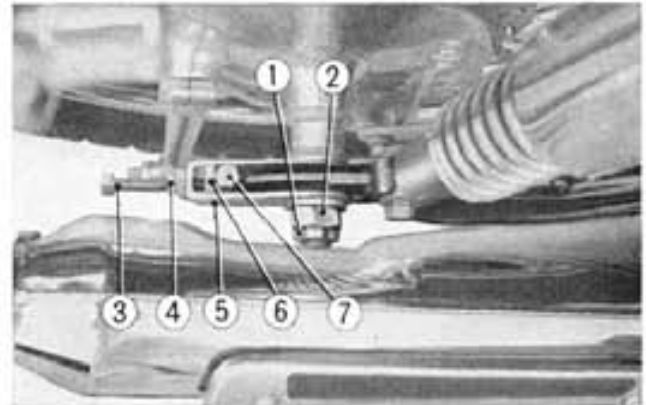


Fig. 13-17 ① Cotter pin ⑤ Chain adjuster
② Rear axle nut ⑥ Fork cap
③ Drive chain adjusting bolt ⑦ Fork cap fixing bolt
④ Lock nut

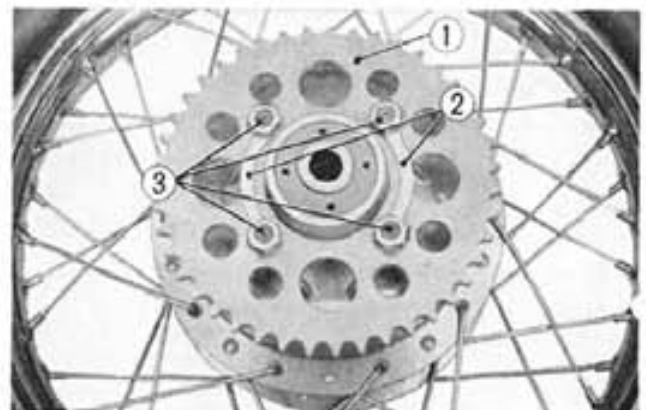


Fig. 13-18 ① Final driven sprocket
② Tongued washers
③ Sprocket setting bolts

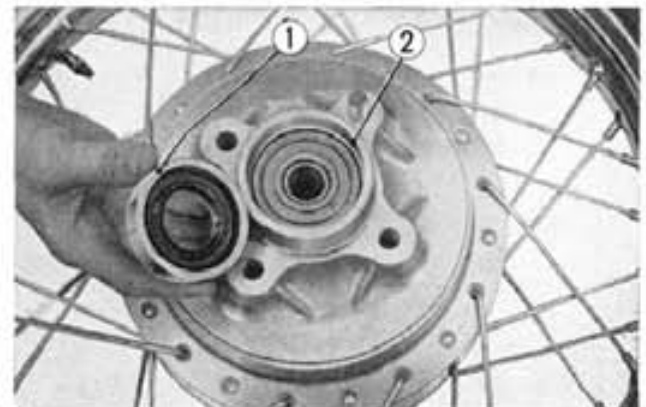


Fig. 13-19 ① Rear wheel bearing retainer
② 6304 ball bearing

10. Remove the two cotter pin, washer and then the rear brake shoes can be removed from the rear brake panel. (Fig. 13-20)

c. Inspection

1. Rear brake lining
Refer to section 14-3 c on page 148.
2. Rear brake shoes
Refer to section 14-3 c on page 148.
3. Wheel ball bearing (Fig. 13-8)
Measure the axial and diametrical runout of the ball bearing with a dial gauge. If the value is over serviceable limit listed below the ball bearing should be replaced.

| Item | Serviceable limit |
|--------------------|---------------------|
| Axial runout | 0.004 in. (0.1 mm) |
| Diametrical runout | 0.002 in. (0.05 mm) |

d. Reassembly

1. Install the rear brake shoes on the rear brake panel and install the washer, two cotter pins and bend the pins.
2. Clean the inside of the drum so that it is free of oil, dust and other foreign objects, and then install the brake panel.
3. Mount the bearing retainer on the wheel hub, install the driven sprocket with the mounting nuts and bend up the tab on the locking washer to prevent loosening.
4. Install the rear wheel on the frame.
5. Assemble the torque link bolt, washers, nut and lock pin on the rear brake panel. Install the brake lever rod on the brake arm and install the brake adjusting nut.
6. Adjust the drive chain tension with the adjuster bolt so that there is a slack of **0.40 to 0.80 in. (10~20 mm)**, at the center of the chain. After completing the adjustment tighten the axle nut and lock with a cotter pin. (Fig. 13-21)
7. Adjust rear brake pedal free play. (refer to page 48).

Note: At any time the front or rear wheel is removed, take the opportunity to thoroughly inspect the suspension components, brake friction linings and wheel assemblies. Pay particular attention to the condition of the wheel bearings, wheel rim, tire bead seating and spoke tension.

8. Balance the wheel
Perform the balancing in the following procedures. (Fig. 13-22)
 - a. Raise the wheel off the ground and lightly rotate.
 - b. Lightly attach an appropriate weight on the spoke adjacent to the nipple which stop at the highest position. Weights are available in four types, 5 gr, 10 gr, 15 gr and 20 gr.
- c. The wheel is in proper balance if the

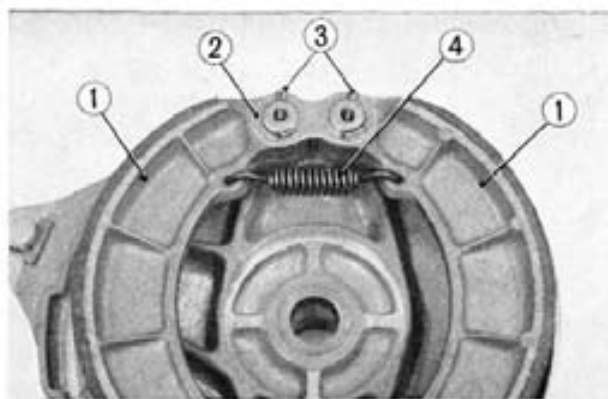


Fig. 13-20

- ① Rear brake shoes ③ 25×20 cotter pin
② Anchor pin washer ④ Brake shoe spring



Fig. 13-21

mounting nuts and bend up the tab on the

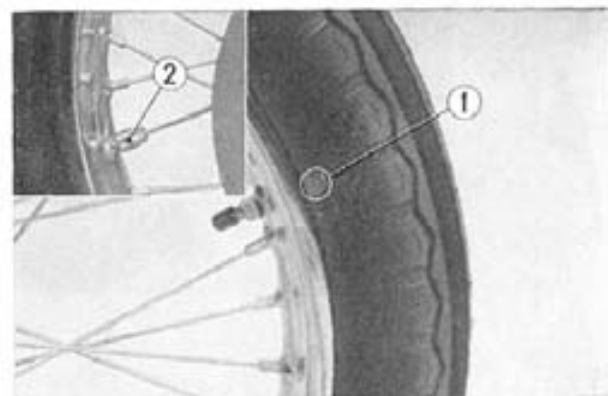


Fig. 13-22

- ① Balance mark
② Balance weight

- wheel after spinning will come to rest at no definite position.
- d. If the wheel does not statically balance, change the weight and reperform items b and c.
- e. Lock the weight with pliers after completing the balance.

13-4 FINAL DRIVE

a. Description

The power from the engine is transmitted from the final drive sprocket by the drive chain to the final driven sprocket mounted on the rear wheel and turns the rear wheel.

b. Disassembly

1. Remove the rear crankcase cover.
2. Remove the joint clip with a pliers to disconnect the chain. (Fig. 13-23)
3. Disconnect the chain by separating the retainer plate and retainer, and remove the chain from the sprocket.
4. For the procedure on the removal of the final drive sprocket, refer to page 137, rear wheel removal section.

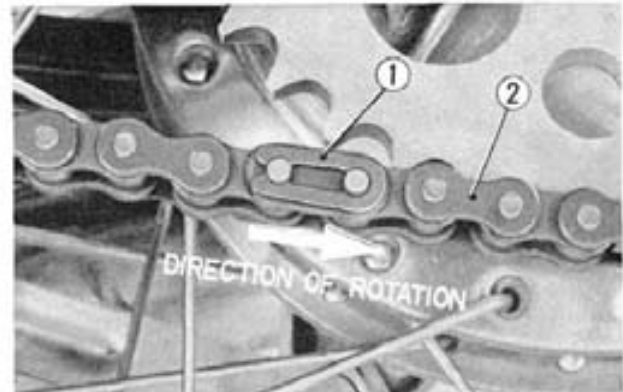


Fig. 13-23 ① Joint clip
② Drive chain

c. Inspection

1. Check the chain stretch

Hang the chain by one end and measure the entire length of the chain between the two pin holes. If the stretch of the chain is computed to be greater than **0.4 in (10 mm)** for one meter of length, the chain should be replaced. (Fig. 13-24)
2. Check for any cracks in the chain.
3. Visually inspect the sprocket teeth and replace the sprocket if there are any broken teeth or excessively worn teeth.
4. If the chain is excessively dirty, clean the drive chain by referring to page 187.

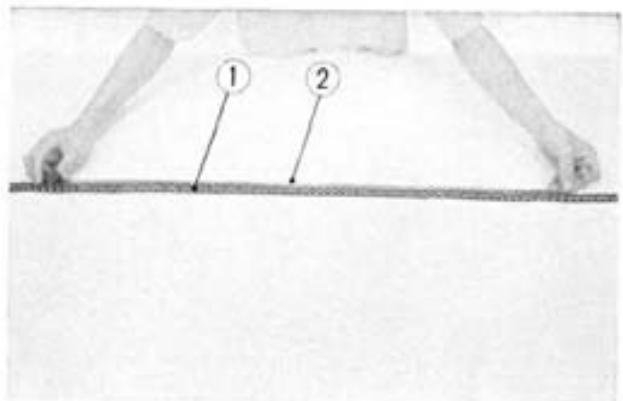


Fig. 13-24 ① Drive chain
② Scale

d. Reassembly

1. Reassembly is performed in the reverse order of disassembly, however, exercise care on the following points:
 - a. After reassembly, perform the drive chain adjustment by referring to page 178.
 - b. The drive chain clip must be installed so that the cutout is toward the trailing end.

BRAKES

GROUP

14

CONTENTS

| | |
|---------------------------------------|-----|
| 14-1 GENERAL DESCRIPTION | 141 |
| SPECIFICATIONS | 141 |
| DIAGNOSIS | 142 |
| 14-2 FRONT BRAKE | 142 |
| a. Description | 142 |
| b. Disassembly | 143 |
| c. Inspection | 145 |
| d. Reassembly | 146 |
| 14-3 REAR BRAKE | 148 |
| a. Description | 148 |
| b. Disassembly | 148 |
| c. Inspection | 148 |
| d. Reassembly | 148 |

14-1 GENERAL DESCRIPTION

SPECIFICATIONS

| Item | Standard value | Serviceable limit |
|----------------------------------|---|---|
| Front brake disc thickness | 0.272~0.279 in 6.9~7.1 mm Max. 0.004 in | under 0.217 in 5.5 mm over 0.012 in |
| Front brake disc deflection | 0.1 mm | 0.3 mm |
| Master cylinder inner diameter | 0.5512~0.5529 in 14.0~14.043 mm | over 0.553 in 14.055 mm |
| Master cylinder piston diameter | 0.550~0.5506 in 13.957~13.984 mm | under 0.549 in 13.940 mm |
| Caliper cylinder inner diameter | 1.503~1.504 in 38.18~38.20 mm | over 1.504 in 38.215 in |
| Caliper cylinder piston diameter | 1.505~1.515 in 38.115~38.48 mm | under 1.500 in 38.105 mm |

DIAGNOSIS

| Trouble | Probable Causes | Remedy |
|-----------------|--|--|
| Defective brake | 1. Front brake <ul style="list-style-type: none"> • Insufficient brake fluid. • Air in the brake system. • Worn brake pad. • Worn piston. • Worn or distorted front brake disc. • Brake lever out of adjustment. 2. Rear brake <ul style="list-style-type: none"> • Worn brake lining. • Worn brake shoe or poor contacts. • Worn brake cam. • Wet brake from water or oil. • Worn brake shaft. • Brake pedal out of adjustment. | Add brake fluid. Bleed brake system Replace pad Replace piston Replace disc Readjust Replace Replace Replace Clean Replace Readjust |

14-2 FRONT BRAKE

a. Description

The CB750 employs a hydraulically operated disc brake on the front wheel which provides smooth and stable braking from slow to high speed.

The disc brake system is composed of the brake lever and master cylinder on the right handle bar, a caliper mounted on the left side front fork and the stainless steel disc mounted on the wheel hub.

Operation takes place in the following sequence. (Fig. 14-1)

1. When the front brake lever ① is gripped, the cam ② at the base of the brake lever will actuate the master cylinder ③ and pressurizes the fluid within chamber A.
2. Pressurized fluid in the system actuates the stop light switch ⑧ installed in the 3-way joint ⑦, and pad A ⑩.

The pressure built-up within chamber B forces pad A ⑩ against disc to produce braking. As the caliper assembly is pivoted to the front fork housing, the reaction from pad A ⑩ is transmitted to pad B ⑭.

3. The clearance of 0.002~0.004 in (0.05~0.1 mm) between the disc and the pad to be consistent with the wear of the pad. When hydraulic pressure is applied against the back of the piston, the piston seal first deforms and as the piston moves further, the piston slides over the piston seal until the pad contacts the disc (Fig. 14-2). When the hydraulic pressure is released, the deformed piston seal will return to its normal shape, and consequently, pulls the piston away from the disc by the amount of the piston seal deformation.
4. When the brake lever is released, the spring within the master cylinder returns the primary cup and the piston to their original positions, pressure within the brake system is relieved.

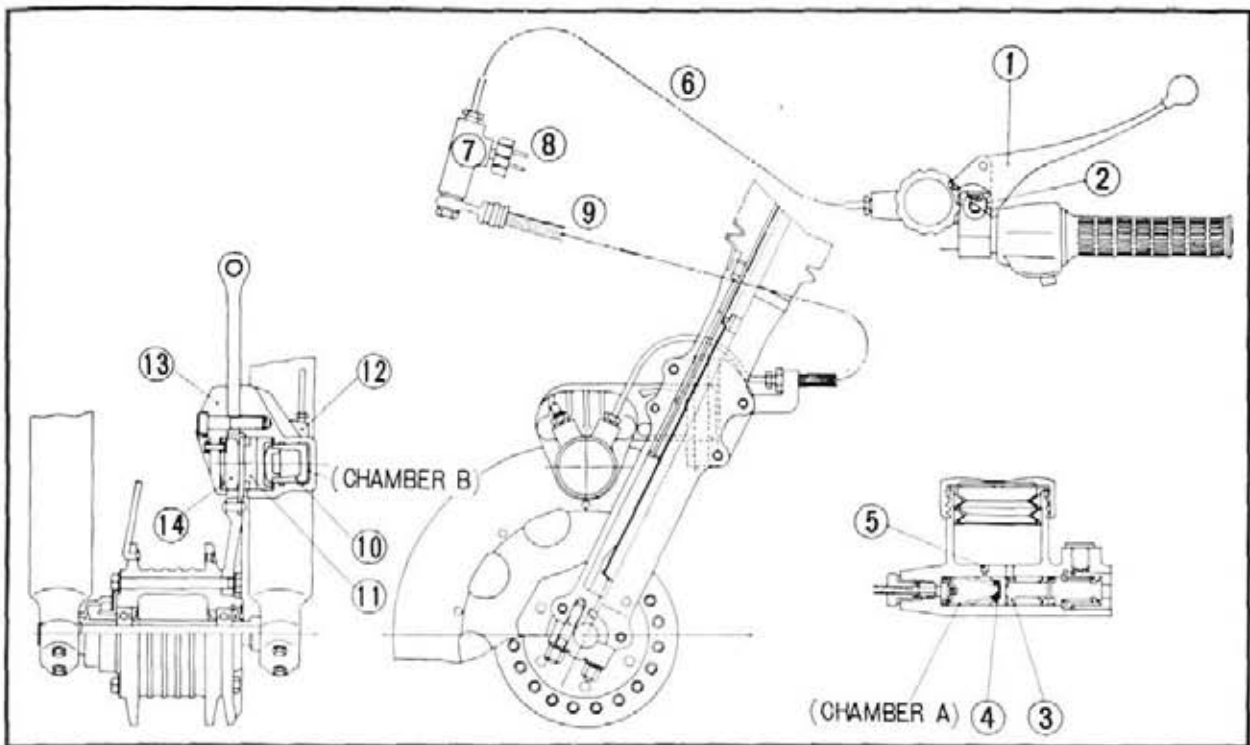


Fig. 14-1 ① Front brake lever
 ② Front brake lever cam
 ③ Master cylinder
 ④ Primary cup
 ⑤ Fluid passage
 ⑥ Front brake hose B
 ⑦ Three way joint
 ⑧ Stoplight switch
 ⑨ Front brake hose
 ⑩ Piston
 ⑪ Pad A
 ⑫ Caliper A
 ⑬ Caliper B
 ⑭ Pad B

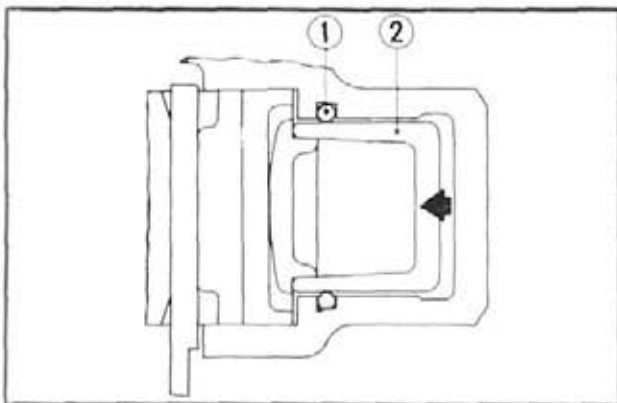


Fig. 14-2 ① Piston sea
 ② Piston

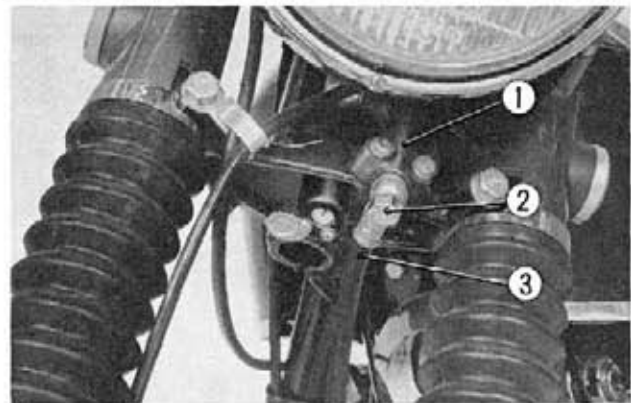


Fig. 14-3 ① Joint ③ Oil hose
 ② Oil bolt

b. Disassembly

1. Remove the front wheel by referring to page 132.
2. Disconnect the front brake hose at the joint by removing the oil bolt. (Fig. 14-3)
3. Unscrew the three caliper mounting bolts from the fork bottom case, and remove the caliper assembly.

To remove caliper B, unscrew the two hollow head set bolts and this will also permit caliper A to remove. (Fig. 14-4)

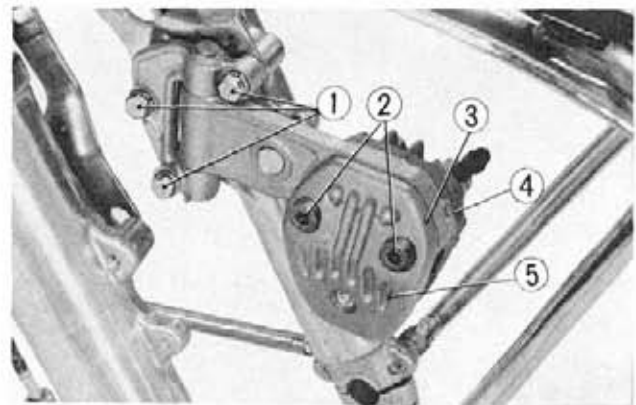


Fig. 14-4 ① Caliper mounting bolts
 ② Hollow head set bolts
 ③ Caliper B ⑤ Caliper B
 ④ Caliper A

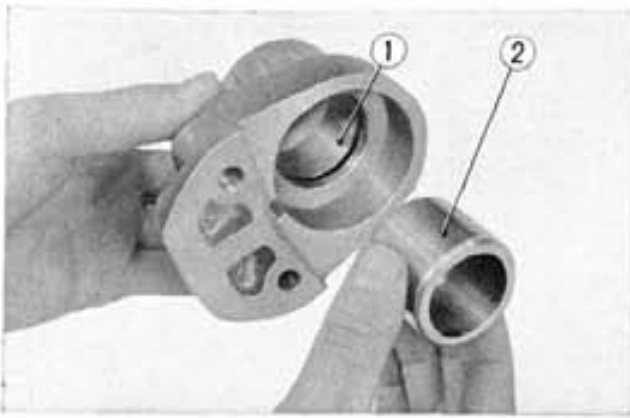


Fig. 14-5 ① Caliper A ② Piston

4. Remove the pad A, pad seat and cylinder piston from caliper A. (Fig. 14-5)
5. Remove the pad B from the caliper B by removing the cotter pin.
6. The master cylinder assembly removal can be performed in the following manner. First unscrew the oil bolt at the master cylinder. (Fig. 14-6)
7. Unscrew the two master cylinder setting bolts and remove the master cylinder from the right side handle grip.
8. Remove the stopper washer and boot from the master cylinder body. (Fig. 14-7)

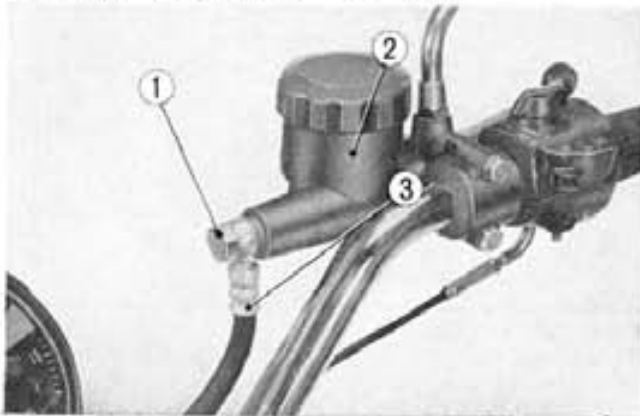
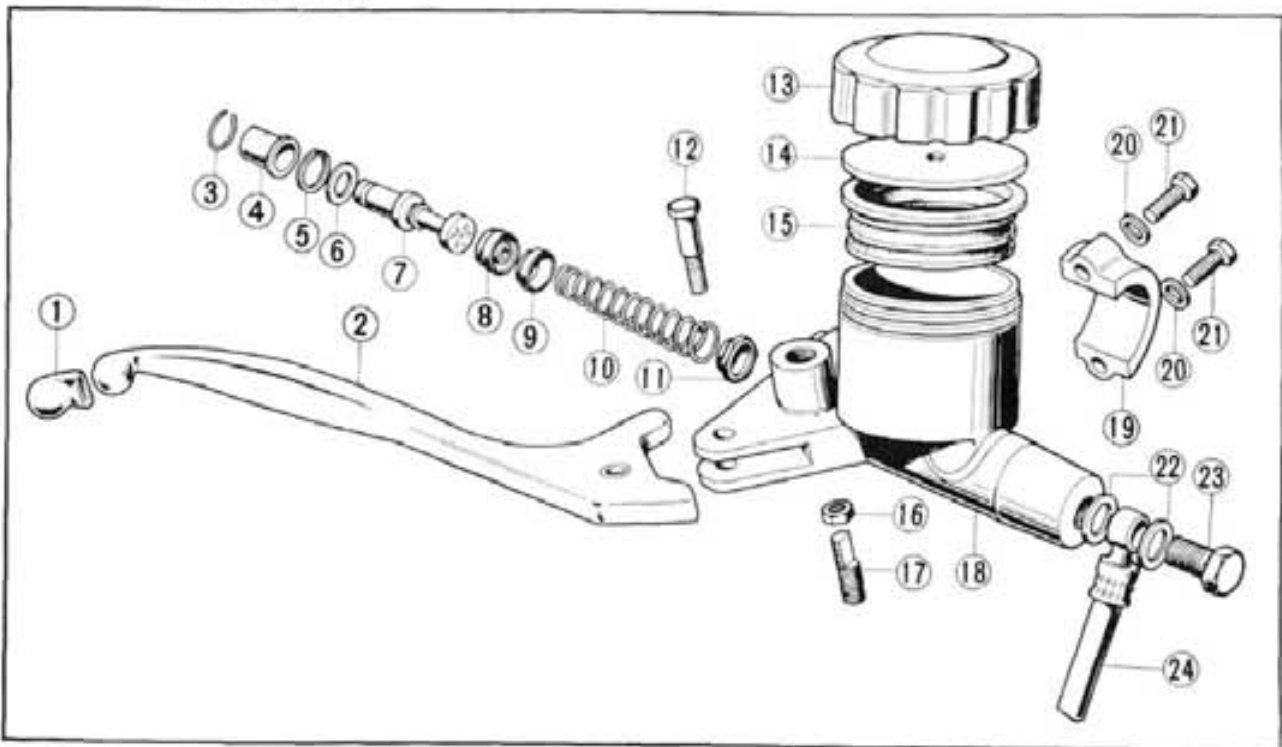


Fig. 14-6 ① Oil bolt ② Master cylinder ③ Oil hose



- | | | |
|--------------------------|---------------------------|--------------------------|
| ① Brake lever cap | ⑨ Primary cap | ⑰ Lever adjusting bolt |
| ② Brake lever | ⑩ Spring | ⑱ Master cylinder body |
| ③ Stopper washer | ⑪ Check valve | ⑲ Master cylinder holder |
| ④ Boot | ⑫ Handle lever pivot bolt | ⑳ 6 mm spring washer |
| ⑤ 18 mm internal circlip | ⑬ Oil cup cap | ㉑ 6 mm hex bolt |
| ⑥ 10.5 mm washer | ⑭ Master cylinder plate | ㉒ Oil bolt washer |
| ⑦ Piston | ⑮ Diaphragm | ㉓ Oil bolt |
| ⑧ Secondary cap | ⑯ 8 mm hex nut | ㉔ Front brake hose |

Fig. 14-7

9. Remove the circlip from the master cylinder body using the special circlip pliers (Tool No. 07914-3230000). (Fig. 14-8)
10. Next, remove 10.5 mm washer, piston, secondary cup, primary cup, spring and check valve. (Fig. 14-7)

c. Inspection

1. Brake friction pads

If the clearance between the front of the caliper and brake disc face becomes **0.06~0.08 in. (1.5~2 mm)**, friction pads should be replaced with new Honda genuine friction pads. (Refer to page 185)

Both friction pads (the one which is on the caliper piston and the other on the opposite side) should be changed in set at the same time.

2. Front disc brake inspection

Raise the stand, push the motorcycle, apply the brake lever and check to make sure that the front brake is fully operational. If a large stroke of the lever is required before the braking becomes effective, the cause may be either low brake fluid in the system or air may be present in the system; in which case, check the reservoir and replenish the fluid if necessary or if air bleeding is required, refer to the section on bleeding of braking system (page 138~139). This should automatically correct the level breaking stroke.

However, if the length of the free stroke is excessively large, brake lever adjustment may be necessary.

Loosen the brake lever adjusting lock nut and turn the adjusting bolt to obtain the proper play.

After completing the adjustment, do not forget to tighten the lock nut. (Fig. 14-9)

3. Caliper cylinder piston

Accurately measure the caliper cylinder using inside dial gauge, and the piston using a micrometer. When the clearance between piston and the cylinder is greater than **0.004 in. (0.11 mm)**, the worn parts

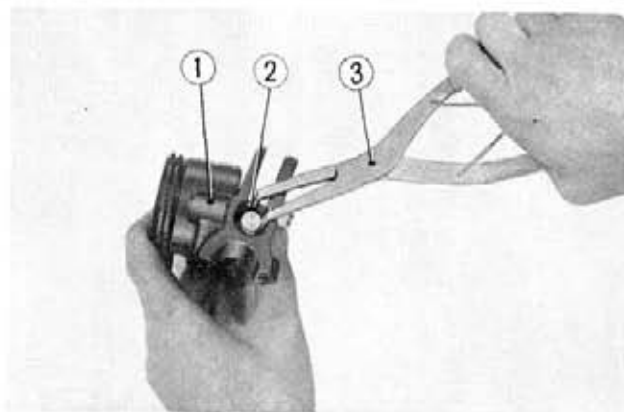


Fig. 14-8 ① Master cylinder body
② Circlip
③ Special pliers

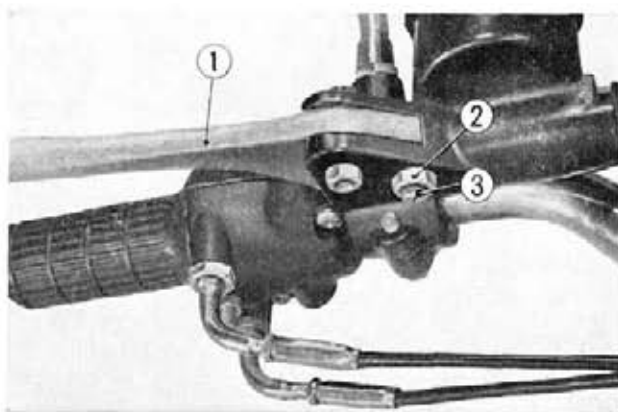


Fig. 14-9 ① Front brake lever
② Lock nut
③ Brake lever adjusting bolt

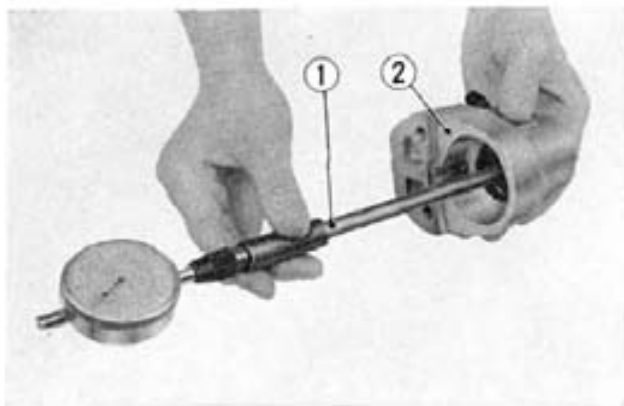


Fig. 14-10 ① Cylinder gauge
② Caliper cylinder

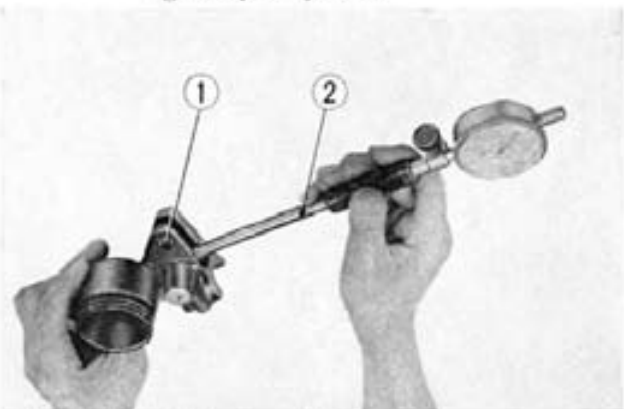


Fig. 14-11 ① Master cylinder body
② Inside dial gauge

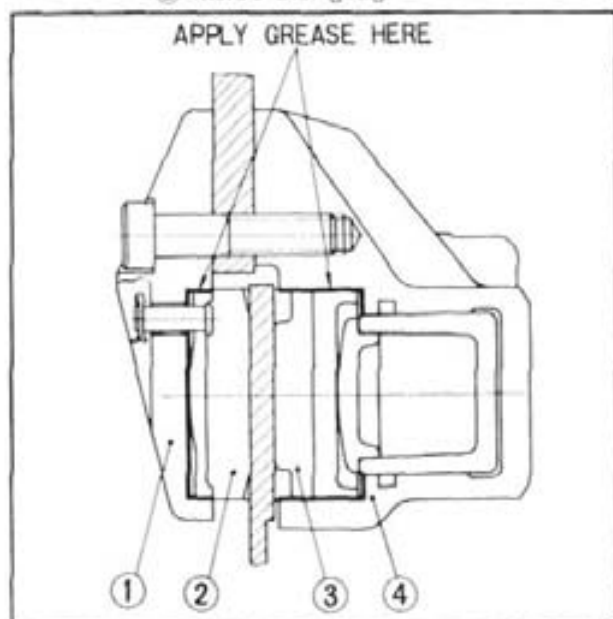


Fig. 14-12 ① Caliper B ③ Pad A
② Pad A ④ Caliper A

3. Install the front wheel (Refer to page 133~134).
4. Bleeding the brake system

The brakes must be bled with great care subsequent to work performed on the brake system, when the lever becomes soft or spongy or when lever travel is excessive. This procedure is best performed by two mechanics.

- a. Remove the dust cap from the bleeder valve and attach bleeder hose. (Fig. 14-13)

should be replaced. (Fig. 14-10)

| Inspecting item | Serviceable limit |
|-----------------|--|
| Cylinder | Replace if beyond 1.504 in. (38.215 mm) |
| Piston | Replace if under 1.500 in. (38.105 mm) |

4. Master cylinder piston (Fig. 14-11)

Accurately measure the cylinder using an inside dial gauge, and the piston using a micrometer. If the clearance between the cylinder and piston is greater than **0.0045 in. (0.115 mm)**, the worn parts should be replaced.

| Inspecting item | Serviceable limit |
|------------------------|--|
| Master cylinder | Replace if beyond 0.553 in. (14.055 mm) |
| Master cylinder piston | Replace if under 0.549 in. (13.940 mm) |

5. Check seal of the caliper piston and if found to be damaged, replace with a new part.
6. Check the oil hose for damage, if it is defective, replace it with new part.

d. Reassembly

1. Before mounting the pads A and B, apply a small amount of the specified grease (0.3~0.5 g) evenly on the caliper as shown in Fig. 14-12. When mounting the pads, take care not to smear the braking surface of the pad with grease. The applied grease serves to prevent dust and water from entering the pad sliding surface, as well to lubricate the sliding surface in order to ensure the smooth operation of the pads.

Note: Use silicon sealing grease (temperature range of $-67\sim 392^{\circ}\text{F}$, $(-55\sim 200^{\circ}\text{C})$. Do not use molybdenum grease known as brake grease.

2. Mount the component parts into the caliper and assemble it on the front fork bottom case.

Place the free end of the bleeder hose into a glass container.

- b. Remove the reservoir cap and fill the reservoir with **DOT 3** or **SAE J1703a BRAKE FLUID**. Place the cap on the reservoir to prevent the entry of dust. (Fig. 14-14)
- c. As shown at right, attach a rubber of about 15 mm thick to the end of the handle grip to decrease the stroke as measured at the tip of the handle lever.

Rapidly pump the brake lever several times until pressure can be felt, holding the lever tight, open the bleeder valve by about one half turn and squeeze the lever all the way down. Do not release the lever until the bleeder valve has been closed again.

Repeat this procedure until bubbles cease to appear in the fluid at the end of the hose. Do not allow the fluid reservoir to become empty during the bleeding operation as this will allow air to enter the system again. Replenish the fluid as often as necessary while bleeding.

- d. Remove the bleeder hose, tighten the bleeder valve and install the bleeder valve dust cap. Tighten the reservoir cap after filling brake fluid to proper level.

- e. Check for proper effect of bleeding and absence of leaks while holding pressure against the brake lever.

When the hydraulic brake system has been drained, the reservoir should be first filled with brake fluid.

Open the bleeder valve by one half turn, squeeze the brake lever, close the valve and release the brake lever. This procedure must be repeated in this sequence until hydraulic fluid begins to flow through the bleeder hose. Having filled the hydraulic system with fluid, proceed with the actual bleeding operation.

Note:

- Brake fluid which has been pumped out of the system must not be used again.
- Brake fluid will damage the paint finish and meter cases.
- The hydraulic fluid level in the reservoir must be checked at regular intervals and replenished whenever low. Use only **SAE TYPE 70R3 BRAKE FLUID** in this system.

5. Brake caliper adjustment

The brake caliper must be adjusted so that there is a small clearance between the fixed friction pad and the brake disc. This adjustment is made in the following manner. (Fig. 14-15)

- a. Raise the front wheel off the ground using a suitable prop.

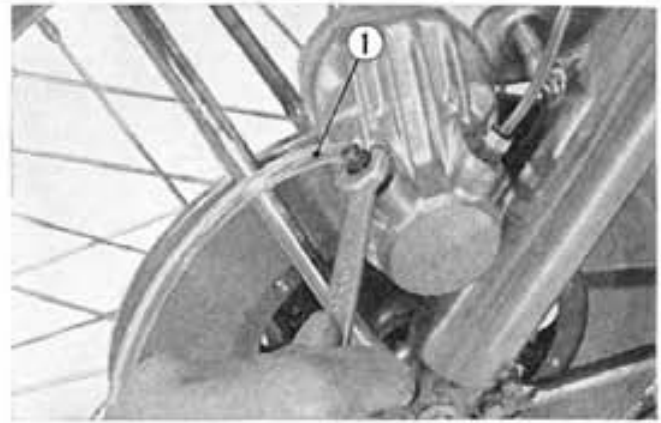


Fig. 14-13 ① Bleeder hose

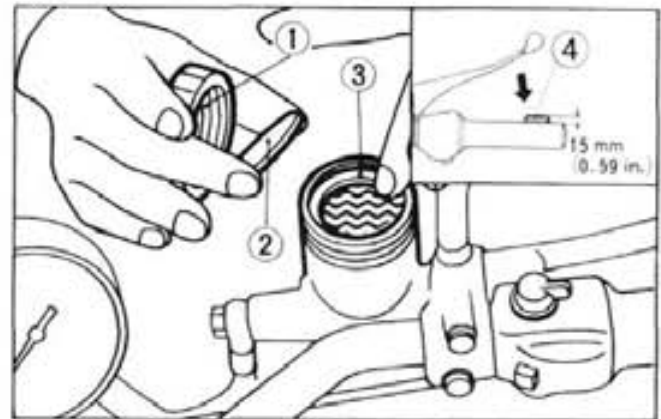


Fig. 14-14 ① Reservoir cap ② Washer ③ Diaphragm ④ Rubber

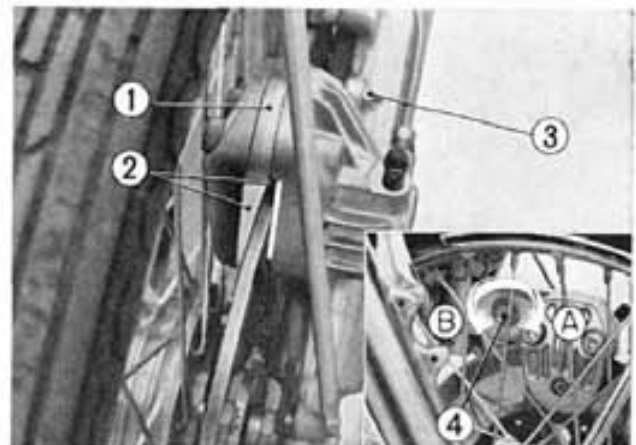


Fig. 14-15 ① Brake caliper ② Friction pads ③ Stopper colt lock nut ④ Stopper bolt

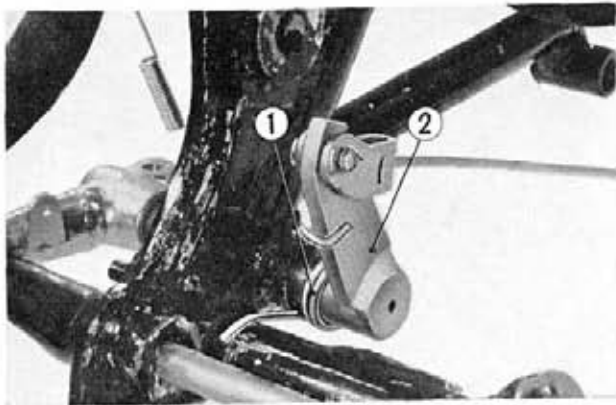


Fig. 14-16 ① Rear brake return spring
② Rear brake shaft

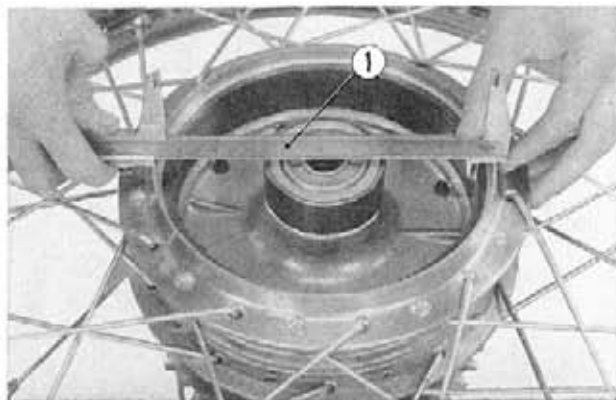


Fig. 14-17 ① Vernier caliper

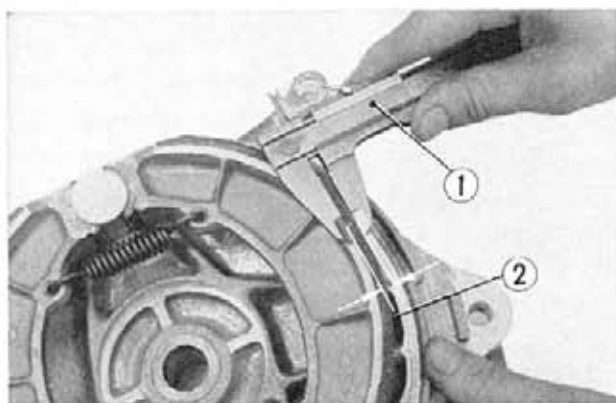


Fig. 14-18 ① Vernier caliper
② Rear brake shoe

- b. Loosen the caliper stopper bolt lock nut.
- c. Turn the stopper bolt in direction Ⓐ until the friction pad contacts the brake disc. When the wheel is rotated some resistance should be noticed.
- d. While rotating the front wheel, turn the stopper bolt in direction Ⓑ until the front wheel rotates freely.
- e. Turn the stopper bolt in direction Ⓒ 1/8 ~ 1/4 turn further and tighten the lock nut.

14-3 REAR BRAKE

a. Description

The rear brake has a large 7.09 in. (180 mm) diameter drum, providing a large friction surface for an effective braking performance.

b. Disassembly

1. Unscrew the rear brake pedal mounting bolt, disconnect the stop switch spring and remove the rear brake pedal from the shaft.
2. Unscrew the rear brake adjuster nut and remove the rear brake rod from the rear brake arm.
3. Unhook the rear brake return spring, and remove the rear brake shaft. (Fig. 14-16)
3. Remove the rear brake shoe from the rear wheel in accordance with page 130.

c. Inspection

1. Rear brake lining

Measure the rear brake drum diameter with a vernier caliper and if it is greater than 7.205 in. (183 mm), the rear wheel should be replaced. (Fig. 14-17)

Further, the rear wheel should also be replaced, if there are severe grooves in the drum.
2. Rear brake shoes

Measure the thickness of the brake shoe with a vernier caliper and if it is less than 0.080 in. (2.0 mm) the shoe should be replaced. Further, shoe should also be replaced, if there is severe uneven wear to the lining. (Fig. 14-18)

d. Reassembly

1. Connect the rear brake rod to the rear brake shaft.

2. Hook the rear brake return spring and connect the rear brake shaft to the frame.
3. Install the rear brake rod on the rear brake arm.
4. Install the rear brake pedal and tighten the setting bolt. (Fig. 14-19)
5. Mount the rear wheel in accordance with group rear wheel on page 138.
6. To check the rear brake pedal free travel, raise the rear wheel off the ground by placing the motorcycle on the main stand. Rotate the wheel by hand and note the distance the pedal tip travel before the brake takes hold. Nominal free travel is approximately 1 in. (25 mm) (Fig. 14-20). If adjustment is necessary, make the adjustment by turning the adjusting nut. Turn clockwise for less free travel, counterclockwise for greater free travel. (Fig. 14-21)

Note: Make sure that the cut-out on the adjusting nut is seated on the brake arm pin after the final adjustment has been made. If the rear wheel assembly has been moved forward or rearward, as during drive chain adjustment, the rear brake may require adjustment.

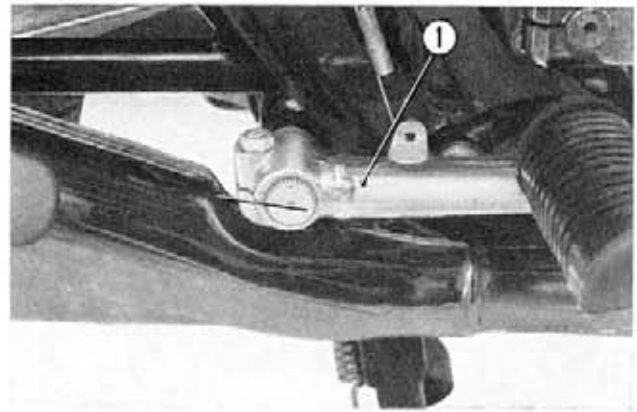


Fig. 14-19 ① Rear brake pedal

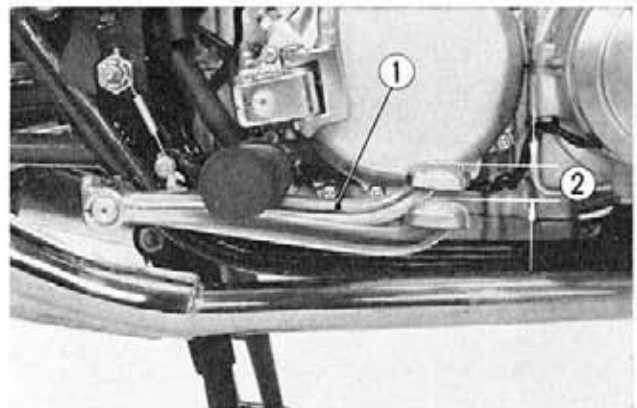


Fig. 14-20 ① Rear brake pedal
② Rear brake pedal free travel

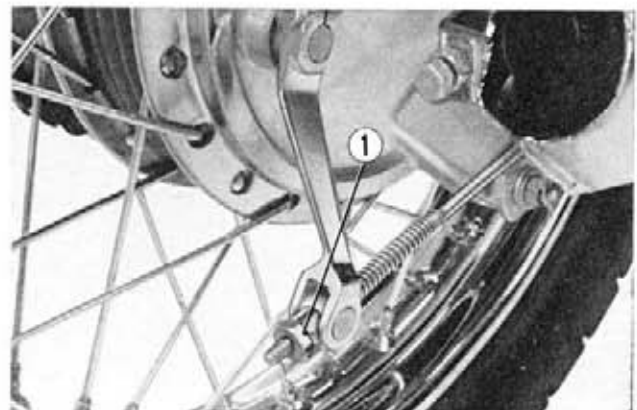


Fig. 14-21 ① Rear brake adjusting nut

BODY, OIL TANK, AIR CLEANER AND EXHAUST SYSTEM

GROUP
15

CONTENTS

| | |
|--|-----|
| 15-1. GENERAL DESCRIPTION | 151 |
| DIAGNOSIS | 151 |
| 15-2. BODY | 152 |
| a. Description..... | 152 |
| b. Disassembly | 152 |
| c. Inspection..... | 152 |
| d. Reassembly..... | 154 |
| 15-3. OIL TANK | 154 |
| a. Description | 154 |
| b. Disassembly | 154 |
| c. Inspection | 155 |
| d. Reassembly | 155 |
| 15-4. AIR CLEANER | 155 |
| a. Description | 155 |
| b. Disassembly | 156 |
| c. Inspection | 156 |
| d. Reassembly | 156 |
| 15-5. EXHAUST SYSTEM | 156 |
| a. Description..... | 156 |
| b. Disassembly | 156 |
| c. Inspection..... | 156 |
| d. Reassembly..... | 156 |

15-1. GENERAL DESCRIPTION

DIAGNOSIS



| Trouble | Probable Cause | Remedy |
|---------------------------|-------------------|-------------------|
| Handle pull to one side | Bent frame | Repair or replace |
| Poor high speed operation | Dirty air cleaner | Clean or replace |

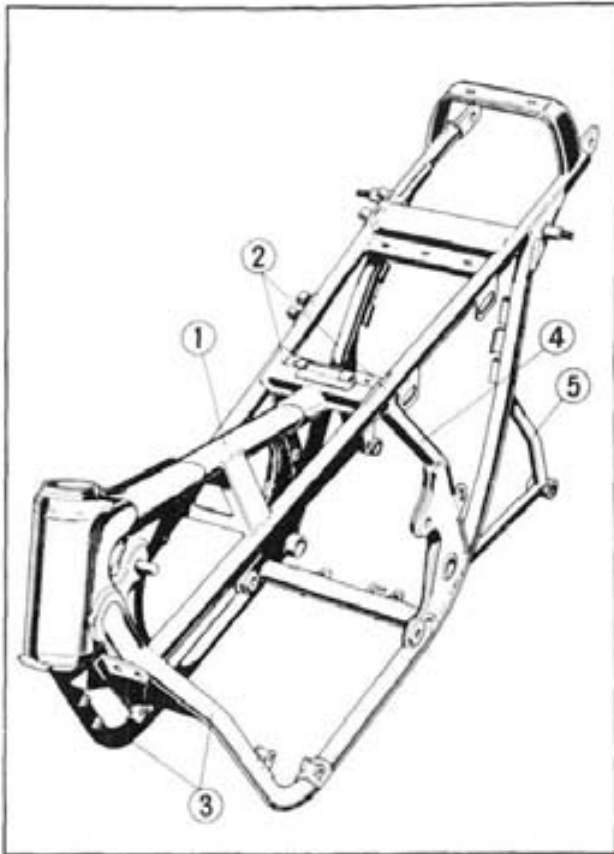


Fig. 15-1 ① Main pipe ④ Center pipe
② Sub tube ⑤ Mufflersetting stay
③ Under sub tube

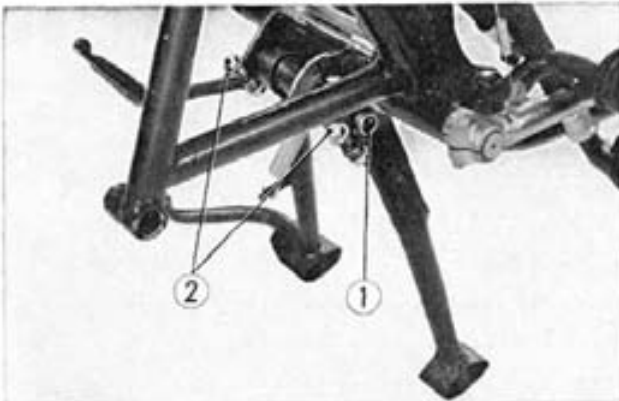


Fig. 15-2 ① Cotter pin
② Main stand mounting bolts

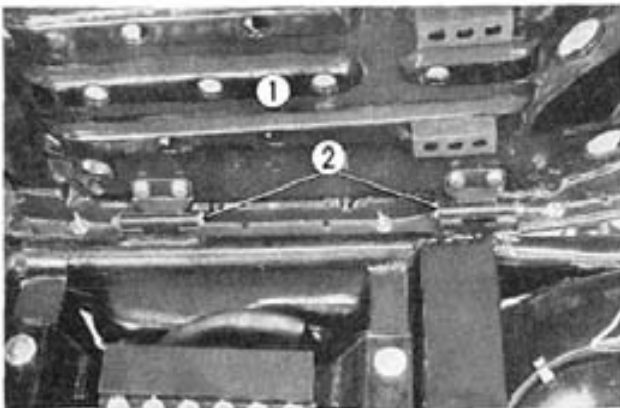


Fig. 15-3 ① Seat
② Seat hinge bars

15-2. BODY

a. Description

The frame of the CB750 is of a double cradle steel tubing construction with a triple down tube head pipe section to provide the higher rigidity required for high speed riding. (Fig. 15-1)

b. Disassembly

1. Refer to engine removal section on page 17~18 to remove the engine.
2. Refer to steering group on page 117~118 to remove the handle, steering stem.
3. Refer to wheel group on page 132 and 137 to remove front and rear wheels.
4. Refer to suspension group on page 120 and 125 to remove the front and rear suspensions.
5. Refer to electrical instrument group on page 160~167 to remove the electrical still going.
6. Remove the cotter pin from the main stand shaft collar and remove the two mounting bolts. (Fig. 15-2)
7. Unhook the main stand spring and remove the main stand.
8. Remove the two seat hinge bars and remove the seat from the frame. (Fig. 15-3)
9. Remove the two 6mm and two 8mm bolts and separate the rear fender, rear fender B from the frame.
10. Remove the upper and lower ball races from the steering head. Use wood blocks to prevent damage when driving out. (Fig. 15-4)

c. Inspection

1. Check for bend and damage to the frame and repair using a press. (Fig. 15-5 shows the dimensions of the frame body.)
2. Check the damages to the lower and top ball races and replace if necessary.

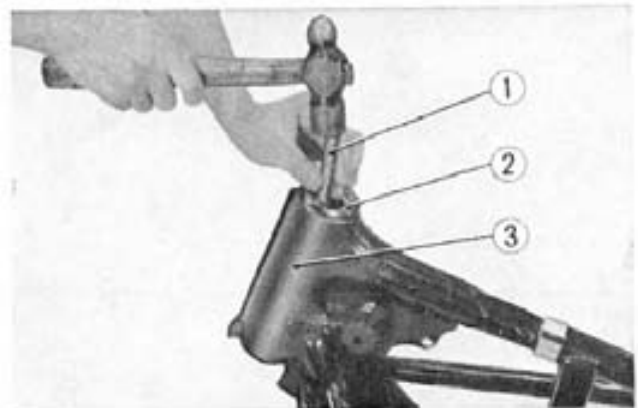


Fig. 15-4 ① Wooden drift ③ Head pipe
② Ball race



Unit: inch (mm)

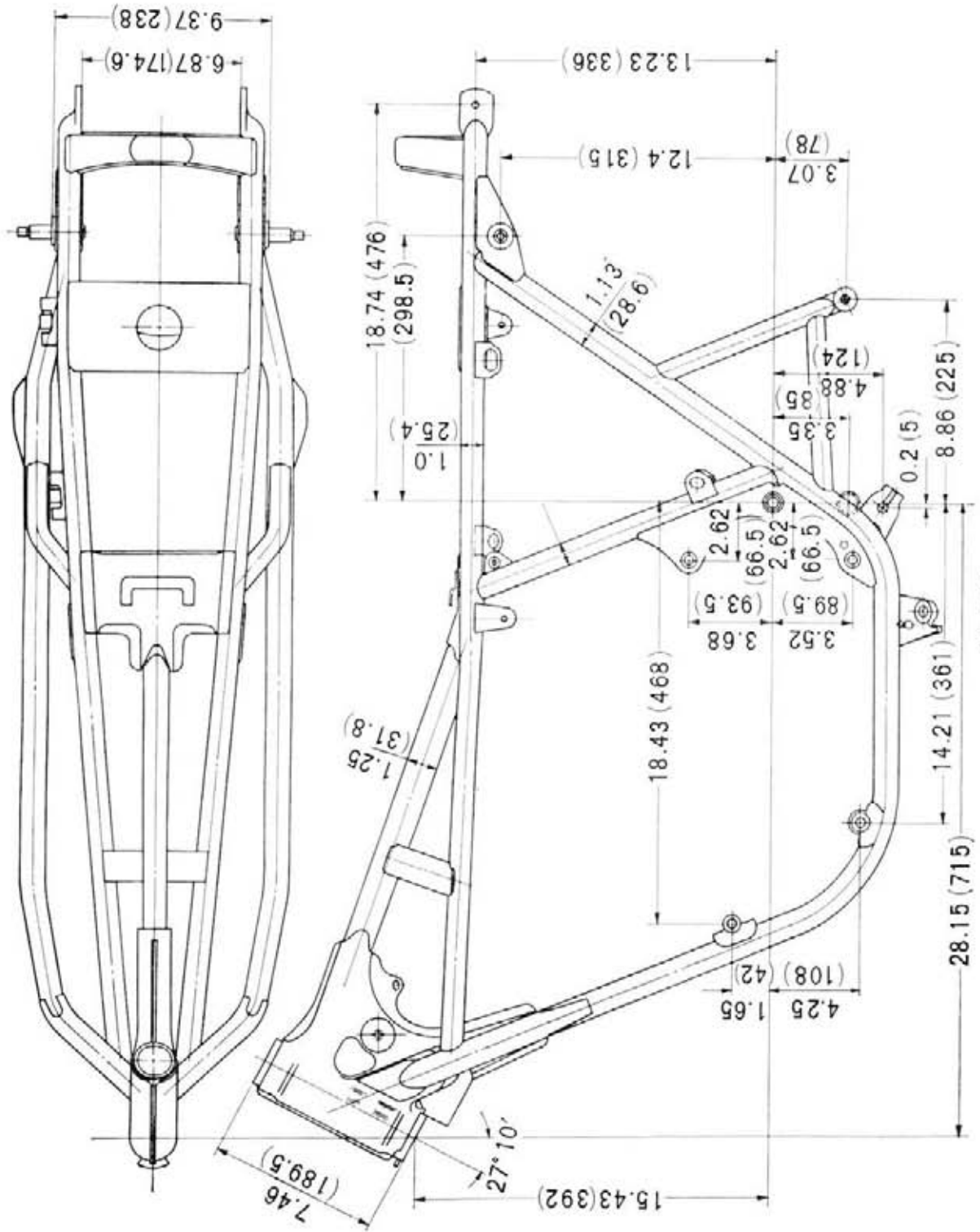


Fig. 15-5

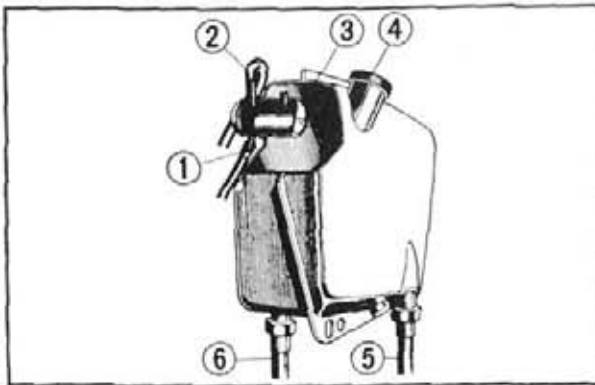


Fig. 15-6 ① Breather tube A
 ② Oil tank breather pipe
 ③ Breather chamber
 ④ Oil filter cap
 ⑤ Oil hose B (scavenge side)
 ⑥ Oil hose A (derivery side)



Fig. 15-7 ① Oil tank drain plug

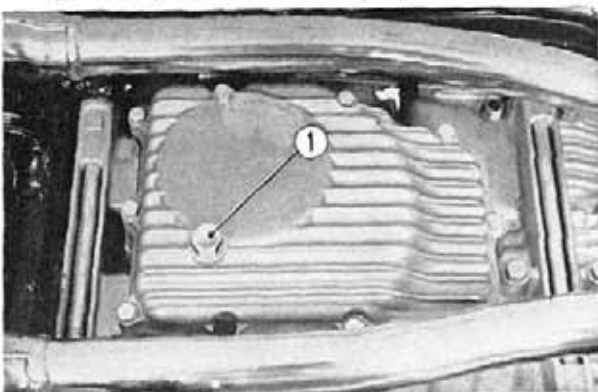


Fig. 15-8 ① Crankcase oil drain plug

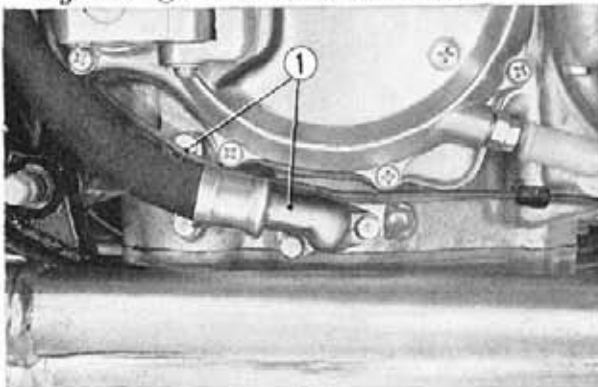


Fig. 15-9 ① Engine oil hoses

3. Inspect the main stand damage, crack bent and repair if condition is serious, the main stand should be replaced.

d. Reassembly

1. Install the upper and lower steering ball races fully into the steering head.
2. Assemble the rear fender and rear fender B on the frame with the 6mm and 8mm bolts (2 of each).
3. Refer to the electrical and instrument group on page 161~170 and install the electrical equipments.
4. Place the main stand against the bracket and insert the main stand shaft and then torque the two mounting bolts.
Note: These bolts should not be over tightened.
5. Install a new cotter pin and lock.
6. Install the seat with the two hinge bars.
7. Refer to the suspension group on page 121 and 125 and install front and rear suspensions.
8. Refer to the wheel group on page 133 and 138 and install front and rear wheels.
9. Refer to the steering group on page 118~119 and install handle steering stem.
10. Refer to the engine installation on page 19, install the engine and also install fuel tank and oil tank.

15-3. OIL TANK

a. Description

The oil tank is mounted on the right side center of the motorcycle and connected to the engine with two hoses. As shown in Fig. 15-6, the oil from the engine is routed through hose B under pressure and is returned to the oil tank: in the reverse, the oil flows through hose A to the engine.

A breather chamber is incorporated within the tank where the oil and air is separated. The air is released through the breather pipe to the atmosphere while the oil entering the breather chamber is returned to the engine through the breather tube A.

b. Disassembly

1. Remove the oil tank cover.
2. Remove the oil tank and crankcase drain plugs, and drain the oil. (Fig. 15-7, 8)
3. Disconnect the two oil hoses at the engine fittings. (Fig. 15-9)

4. Remove the three oil tank mounting bolts and dismount the oil tank. (Fig. 15-10)

c. Inspection

1. Check the oil tank for damages and defects, and replace if tank is leaking.
2. Check the oil hoses fittings for tightness and free from leaks.

d. Reassembly

1. Install the breather pipe and oil hoses securely on the tank.

Note: Make sure that hoses A and B are installed in their respective locations. (Fig. 15-11)

2. Make sure that the oil tank is mounted on the rubber mounts and install three mounting bolts.
3. Install the oil hoses to their respective fittings on the engine.

Note: Make sure not to forget the 15 mm O ring.

4. Install and tighten both the oil tank and crankcase drain plugs.
5. Refill tank with oil (refer to page 178).

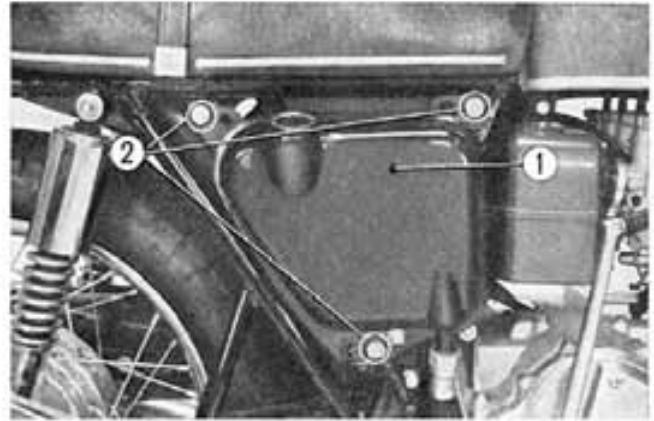


Fig. 15-10 ① Oil tank
② Oil tank mounting bolts

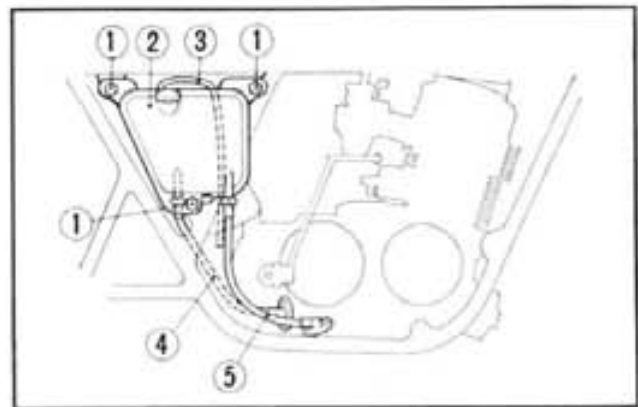


Fig. 15-11
① 6 mm bolts ④ Oil hose A (delivery side)
② Oil tank ⑤ Oil hose B (scavenge side)
③ Breather tube A

15-4. AIR CLEANER

a. Description

The air cleaner is mounted at the center of the motorcycle under the fuel tank. The air cleaner element is of filter paper. The clean air which passes through the air cleaner is fed to the each carburetor. (Fig. 15-12)

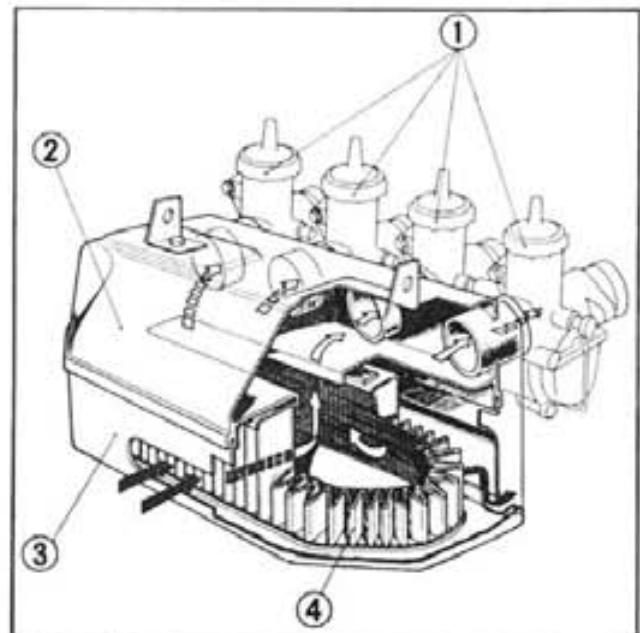


Fig. 15-12 ① Carburetors
② Air cleaner case
③ Air cleaner cover
④ Air cleaner element

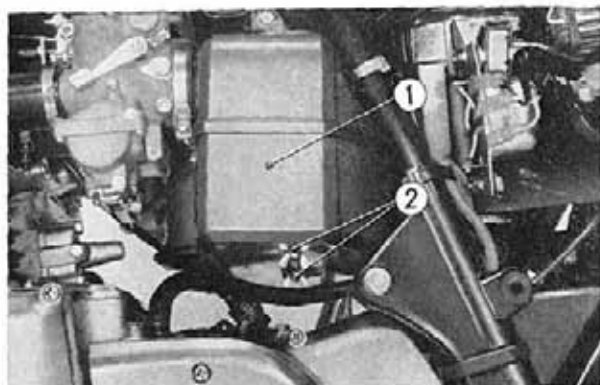


Fig. 15-13 ① Air cleaner cover ② Wing nuts

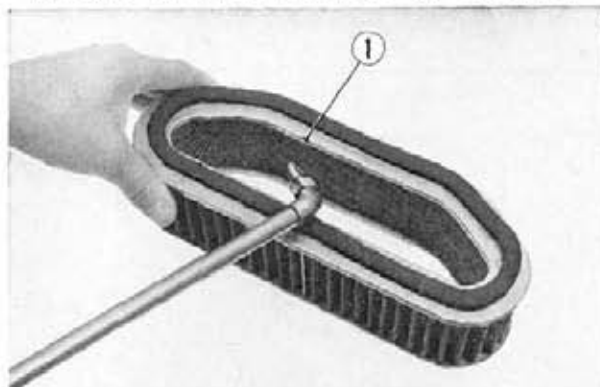


Fig. 15-14 ① Air cleaner element

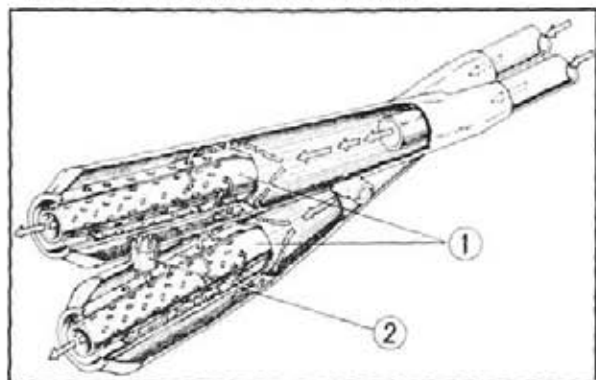


Fig. 15-15 ① Exhaust muffler
② Muffler connecting tube

to the reduction in exhaust back pressure. (Fig. 15-15)

b. Disassembly

1. Loosen the 8 mm bolt on the exhaust joint and remove the pillion step bolt on both sides at the same time.
2. Loosen the muffler connecting band and disassemble the mufflers.

c. Inspection

1. Inspect the muffler gasket for damage.
2. Inspect the muffler for cracks, dents and other defects.

d. Reassembly

1. Install the exhaust pipe gasket on the cylinder head and mount the exhaust flange on the head with two 8 mm screws.
2. Install the exhaust pipe joint on the exhaust flange and mount the muffler to the frame with pillion step bolt and 8 mm bolt.

Note: Make sure that the muffler connecting tube is connecting the upper and lower sections of the muffler. (Fig. 2-9 on page 19)

b. Disassembly

1. Remove the air cleaner cover by loosening the two wing nuts and remove the air cleaner element. (Fig. 15-13)
2. Remove the air cleaner upper case by loosening the four air cleaner hose clamp screws and the two mounting bolts.

c. Inspection

1. Dust on the air cleaner element can be removed by tapping lightly and blowing off the loose dust particles with compressed air. (Fig. 15-14)
2. Inspect the air cleaner element to make sure that it is not damaged or clogged by soilage.
3. Also inspect the bonded section to make sure that the joints are not cracked or open.

d. Reassembly

1. Install the air case by screwing the two air cleaner case setting bolts.
2. Install the air cleaner to the carburetors and clamp the hoses with screws.
3. Install the air cleaner element together with the air cleaner cover and mount with the two wing nuts.

15-5 EXHAUST SYSTEM

a. Description

The CB 750 mounts on individual muffler for each of the four cylinders.

Though the mufflers have only a small expansion chamber capacity, the unique design of the exhaust system provides effective silencing without sacrifice to power output by joining the two mufflers on each side with muffler connecting tube at the silencing compartments. This effect provides an added silencing capacity, with a minimum of power loss due

BODY ELECTRICAL AND INSTRUMENTS

GROUP
16

CONTENTS

| | |
|--|-----|
| 16-1 GENERAL DESCRIPTION | 159 |
| DESCRIPTION | 159 |
| SPECIFICATIONS | 159 |
| 16-2 SPEEDO/TACHOMETER | 159 |
| a. Description | 159 |
| b. Disassembly | 160 |
| c. Inspection | 160 |
| d. Reassembly | 160 |
| 16-3 HEADLIGHT | 160 |
| a. Description | 160 |
| b. Disassembly | 161 |
| c. Inspection | 161 |
| d. Reassembly | 161 |
| 16-4 TAIL/STOP LIGHT | 161 |
| a. Description | 161 |
| b. Disassembly | 161 |
| c. Inspection | 162 |
| d. Reassembly | 162 |
| 16-5 TURN SIGNAL LIGHT | 162 |
| a. Description | 162 |
| b. Disassembly | 162 |
| c. Inspection | 162 |
| d. Reassembly | 162 |
| 16-6 FLASHER RELAY | 162 |
| a. Description | 162 |
| b. Disassembly | 162 |
| c. Inspection | 163 |
| d. Reassembly | 163 |
| 16-7 MAIN IGNITION KEY SWITCH | 163 |
| a. Description | 163 |
| b. Disassembly | 163 |
| c. Inspection | 164 |
| d. Reassembly | 164 |

| | |
|--|-----|
| 16-8 STARTER LIGHTING IGNITION SWITCH | 164 |
| a. Description..... | 164 |
| b. Disassembly..... | 164 |
| c. Inspection..... | 164 |
| d. Reassembly..... | 164 |
| 16-9 TURN SIGNAL LIGHT/HORN SWITCH | 165 |
| a. Description..... | 165 |
| b. Disassembly..... | 165 |
| c. Inspection..... | 165 |
| d. Reassembly..... | 165 |
| 16-10 HORN | 165 |
| a. Description..... | 165 |
| b. Disassembly..... | 165 |
| c. Inspection..... | 166 |
| d. Reassembly..... | 166 |
| 16-11 STOP SWITCH (FRONT) | 166 |
| a. Description..... | 166 |
| b. Disassembly..... | 166 |
| c. Inspection..... | 166 |
| d. Reassembly..... | 166 |
| 16-12 STOP SWITCH (REAR) | 166 |
| a. Description..... | 166 |
| b. Disassembly..... | 166 |
| c. Inspection..... | 166 |
| d. Reassembly..... | 167 |
| 16-13 OIL PRESSURE SWITCH | 167 |
| a. Description..... | 167 |
| b. Disassembly..... | 167 |
| c. Inspection..... | 167 |
| d. Reassembly..... | 167 |
| 16-14 NEUTRAL SWITCH | 167 |
| a. Description..... | 167 |
| b. Disassembly..... | 167 |
| c. Inspection..... | 167 |
| d. Reassembly..... | 167 |
| 16-15 WIRE HARNESS | 168 |
| a. Description..... | 168 |
| b. Disassembly..... | 168 |
| c. Inspection..... | 168 |
| d. Reassembly..... | 170 |



16-1 GENERAL DESCRIPTION

DESCRIPTION

The following equipments are installed on the motorcycle to insure safe riding. Also included are control to operate these equipments.

- Speedo/tachometer
- Lighting equipments
- Switches
- Horn
- Flasher relay
- Wire harness

SPECIFICATIONS

| | |
|--|--------------------------------------|
| Headlight type Headlight bulb | Sealed lamp 12 V-50/40 W |
| Tail/stop light bulb Turnsignal light bulb Meter lamp bulb | 12 V-7/23 W 12 V-25 W 12 V-3 W |
| Flasher relay type Horn | Signal-stat 142 Curling type |

DIAGNOSIS

| Trouble | Probable Causes | Remedy |
|---|---|---|
| Lights do not operate | 1. Broken filament of bulb 2. Poor contact of socket 3. Low charge battery 4. Defective wires | Replace bulb Repair Charge battery Repair or replace |
| Turn signal light does not operate | 1. Defective flasher relay 2. Broken filament of bulb 3. Poor contact of socket 4. Defective wires | Replace Replace Repair Repair or replace |
| Horn does not operate | 1. Low charge battery 2. Poor contact of switch 3. Defective wires | Charge battery Repair Repair or replace |

16-2 SPEEDO/TACHOMETER

a. Description

Speedometer and tachometer are separate units. The speedometer including the odometer and the trip meter is driven from the front wheel through a flexible shaft. Tachometer is driven off the camshaft, also through a flexible shaft. Constructions of both the speedometer is shown in Fig. 16-1.

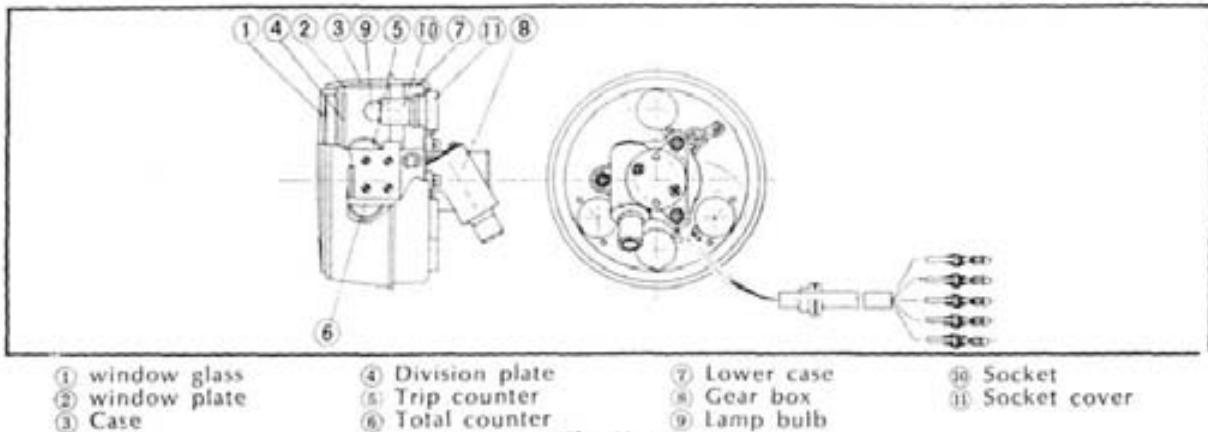


Fig. 16-1

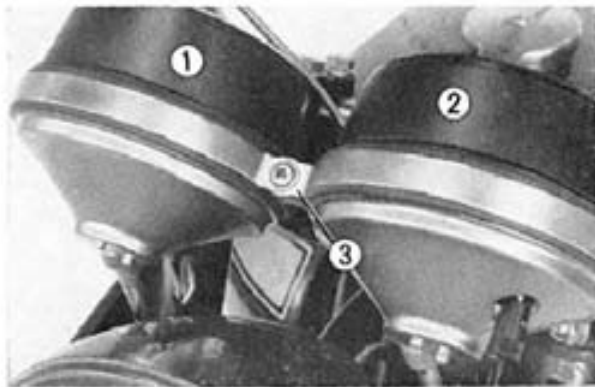


Fig. 16-2 ① Tachometer ② Speedometer ③ Setting screw

b. Disassembly

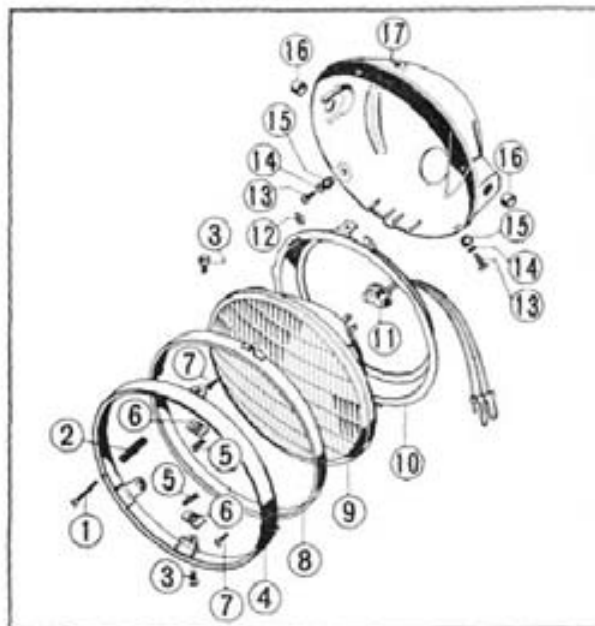
1. Remove the headlight unit in accordance with 16-3. b on page 161, and disconnect the electrical leads which are from the speedo/tachometer.
2. Disconnect the speedometer and tachometer cables from back of the respective meter.
3. Loosen the meter setting screw and remove the meter from the meter bracket. (Fig. 16-2)
4. Remove the meter under plate by unscrewing the two cross screws and remove the meter bulbs.

c. Inspection

1. Inspect the respective meter for defect or crack.

d. Reassembly

Perform the reassembly in the reverse order of disassembly.



- | | |
|-------------------------|----------------------------|
| ① Beam adjusting screw | ⑩ Mounting ring |
| ② Beam adjusting spring | ⑪ Headlight cord socket |
| ③ Unit holder screw | ⑫ Beam adjusting nut |
| ④ Headlight rim | ⑬ 5 mm cross screw |
| ⑤ 5 mm cotter pin | ⑭ 5 mm spring washer |
| ⑥ Unit holder nut | ⑮ Headlight setting collar |
| ⑦ 3 mm cross screw | ⑯ Headlight case collar |
| ⑧ Retaining ring | ⑰ Headlight case |
| ⑨ Sealed beam unit | |

Fig. 16-3

16-3 HEADLIGHT

a. Description

The headlight is of sealed beam type and adjusted in the vertical and horizontal directions. (Fig. 16-3)

c. Disassembly

1. Loosen the three headlight mounting screws and remove the headlight unit from the headlight case.
2. Disconnect the leads from the headlight unit. (Fig. 16-4)
3. Unscrew the two headlight units setting screws, the beam adjusting screw and remove the unit from the headlight rim. (Fig. 16-5)
4. Loosen the two headlight screws and remove the beam unit. (Fig. 16-5)

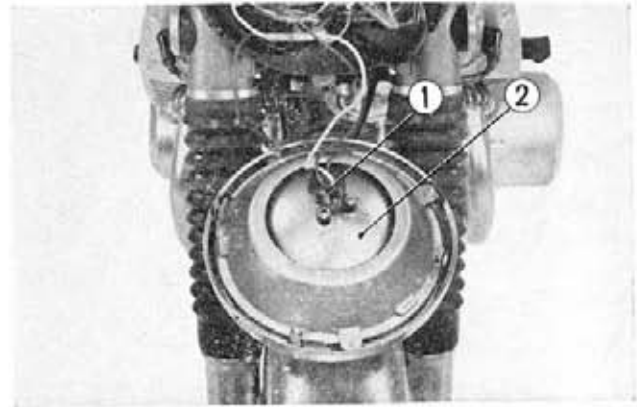


Fig. 16-4 ① Headlight socket ② Headlight unit

c. Inspection

1. If the headlight is inoperative, remove the headlight unit and check for broken filament either visually or with a tester.
If the filament is broken, replace it with a specified headlight unit.
2. Also check the condition of the wiring and if they are damaged or frayed, make a repair or replace the wiring.

d. Reassembly

Perform the reassembly in the reverse order of disassembly.

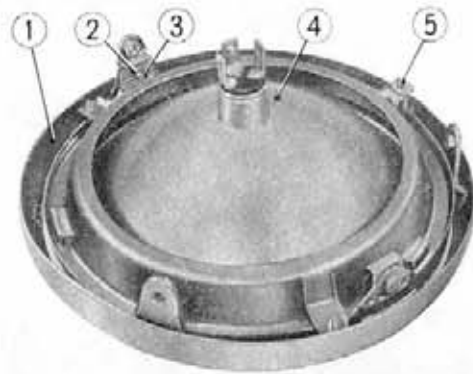


Fig. 16-5 ① Headlight rim ④ Headlight beam unit
② Cotter pin ⑤ Adjusting screw
③ Headlight beam unit screw

16-4 TAIL/STOPLIGHT

a. Description

The tail/stoplight contains two filaments within a bulb. (Fig. 16-6)

b. Disassembly

1. Disconnect the tail/stoplight leads at the connectors and then remove the tail/stoplight bracket. (Fig. 16-7)
2. Remove the taillight lens and then remove the tail/stoplight bulb. (Fig. 16-8)

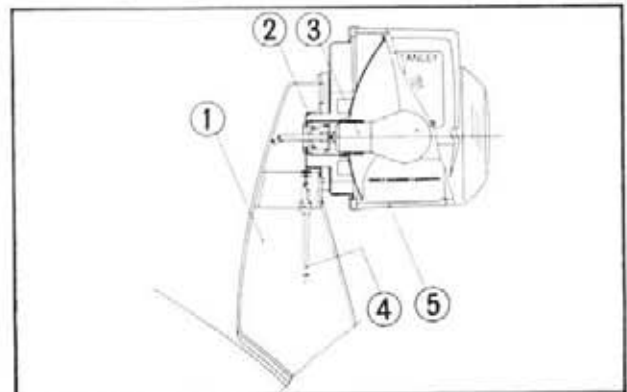


Fig. 16-6 ① Number plate bracket
② Taillight socket ④ Taillight ground cord
③ Taillight bulb ⑤ Taillight lens

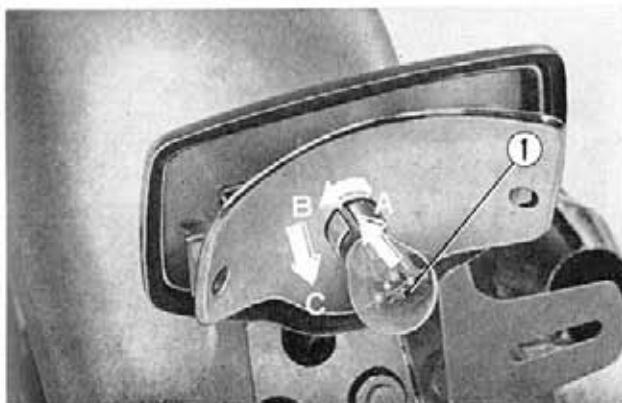


Fig. 16-8 ① Tail/stoplight bulb



Fig. 16-7 ① Lead connectors
② Taillight bracket screws

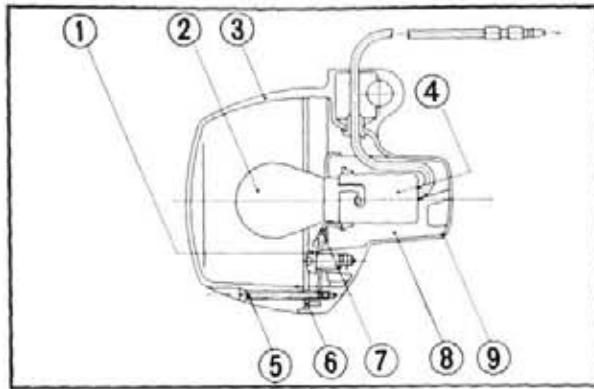


Fig. 16-9 ① Cross screw
 ② Turn signal light bulb
 ③ Turn signal light lens
 ④ Turn signal light socket
 ⑤ Oval screw
 ⑥ Lens packing
 ⑦ Socket holder
 ⑧ Socket cushion
 ⑨ Turn signal light base

c. Inspection

When the bulb does not operate, remove the bulb and check for broken filament visually or with a tester and if found defective, replace the bulb with one that is of a specified rating.

d. Reassembly

Perform the reassembly in the reverse order of removal.

Note: When installing the taillight lens, do not overtighten the screws, as this may damage the lens.

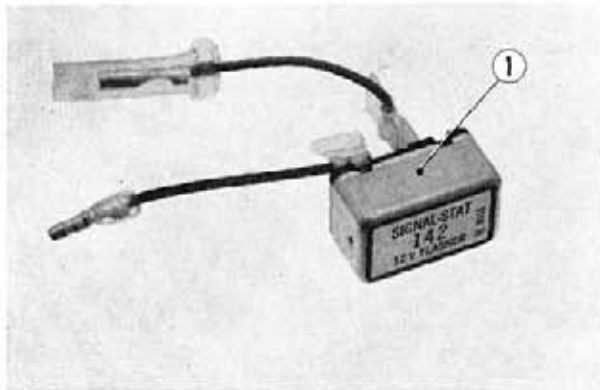


Fig. 16-10 ① Signal-stat flasher relay

16-5 TURN SIGNAL LIGHT

a. Description

A large type turn signal light is used. (Fig. 16-9)

b. Disassembly

The removal procedure is identical with that of the tail/stop light described on page 161.

c. Inspection

1. If the bulb is inoperative, remove the bulb and check for broken filament and if found to be defective, replace the bulb with one of specified rating.
2. Check the wiring for loose connectors or break in the wires and if found defective, repair or replace.

d. Reassembly

Perform the reassembly in the reverse order of removal.

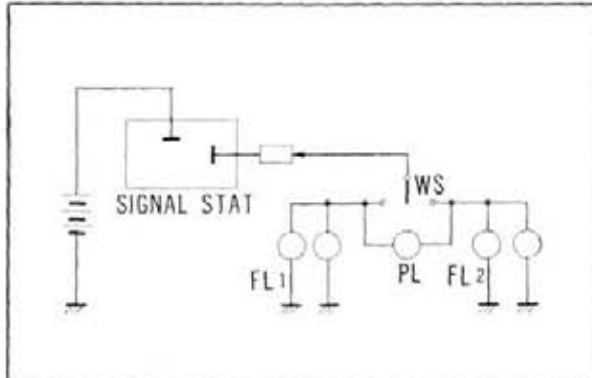


Fig. 16-11 Wiring diagram of signal stat

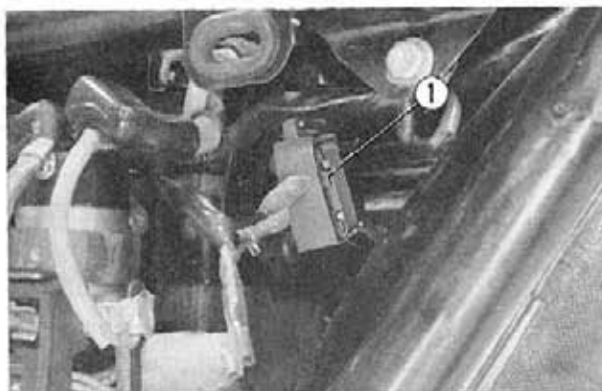


Fig. 16-12 ① Signal stat

16-6 FLASHER RELAY

a. Description

The signal-stat 142 flasher relay is used on this model. (Fig. 16-10)

b. Disassembly

1. Remove the battery cover.
2. Disconnect the electrical leads from the signal stat and remove it.

c. Inspection

1. Make sure that the turn signal light bulb of the proper rating is used. If bulbs of different rating are used, the flashing rate will be affected.
2. Check the operation of the flasher relay.

When the turn signal light flashing rate is not uniform, the flasher relay should be checked. Disconnect the leads from the left terminal of the relay and connect it to a 12V-25W bulb. If the flashing rate is between 65 to 90 cycles per minute, the relay is satisfactory.

Note: During the test make sure that the flasher is properly ground.

3. Switch on the turn signal switch and if the lamp stays on continuously and accompanied by a buzzing noise in the relay, check to make sure that the relay is properly ground or that the ground lead is not broken.
4. When the flasher switch is turned on, and the lamp does not flash, flasher bulb is probably defective. Check the bulb immediately.

d. Reassembly

Perform the installation in the reverse order of removal.

16-7 MAIN IGNITION KEY SWITCH

a. Description

This switch controls the entire electrical circuit including the OFF, ON (riding) and the parking position. (Fig. 16-13)

| | BAT (red) | IG (black) | TL 1 (brown/white) | TL 2 (brown) | Function | Key removal |
|-----|--------------|---------------|-----------------------|-----------------|--|-------------|
| OFF | | | | | Electrical equipments are inoperative and the engine cannot be started | Removal |
| I | ○ — ○ | | ○ — ○ | | Electrical equipments are operative, the engine will start. | Not removal |
| II | ○ | | | ○ | Parking light is operative, engine cannot be started. | Removal |

b. Disassembly

1. Remove the fuel tank.
2. Unscrew the main ignition key switch lock nut. (Fig. 16-14)
3. Disconnect the switch connector and remove the switch. (Fig. 16-14)

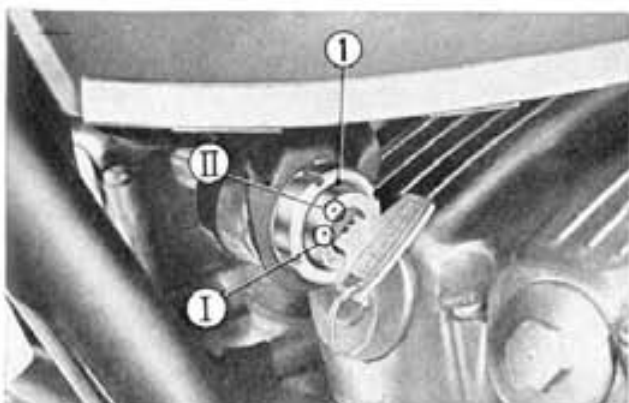


Fig. 16-13 ① Main ignition key switch

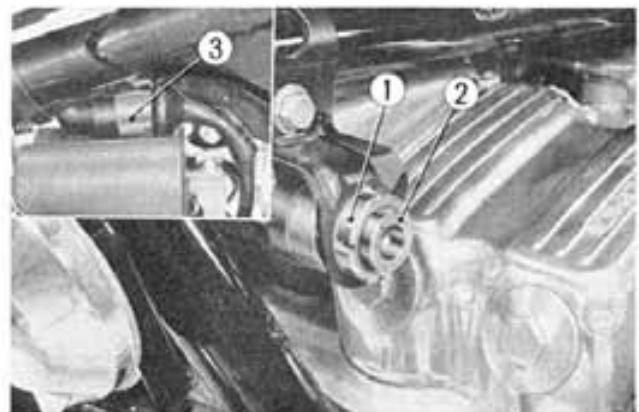


Fig. 16-14 ① Lock nut
② Main ignition key switch
③ Connector

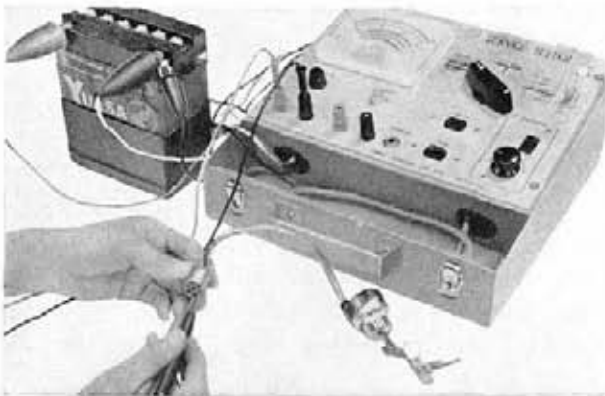


Fig. 16-15 Continuity test of the main key switch

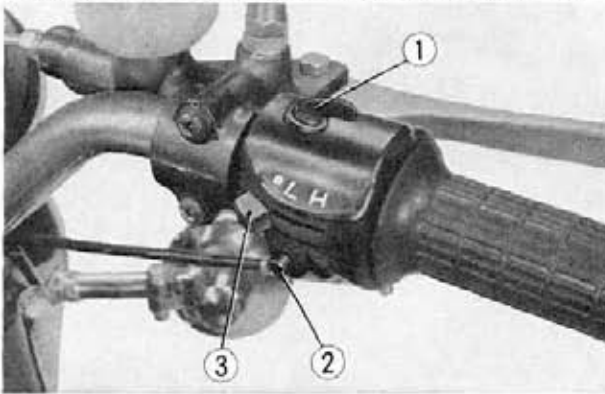


Fig. 16-16 ① Ignition switch
② Starter switch
③ Headlight control switch

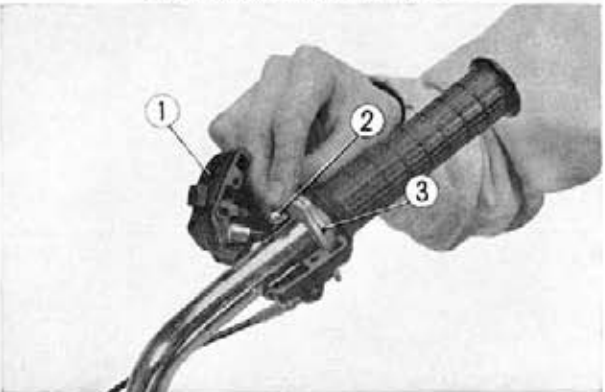


Fig. 16-17 ① Starter lighting ignition switch assembly
② Throttle cable
③ Throttle control

Turn the main key switch to the on position and set the headlight control switch to the red dot position; the headlight and taillight will not be on.

In the L position the headlight low beam will be on; In the H position the headlight high beam will be on. Further, the taillight will be on in both the H and L positions.

2. Push the starter button and check to see if the starting motor turn over.

d. Reassembly

Perform the reassembly in the reverse order of disassembly.

Note: When installing the switch lower half on the handle, make sure that the pin is inserted into the handle bar stopper hole and is tightened together with the switch upper half.

c. Inspection

1. Continuity test

Perform a continuity check to determine if there is a break in the switch lead or defective condition of the contacts. Insert the leads into the X terminal of the tester, turn the selector knob to the continuity position and then turn the main key switch to the on position using the key. Apply the test leads across the points to be checked; if the red continuity lamp is lit, the continuity condition is satisfactory. If the lamp does not come on, it indicates an open circuit. (Fig. 16-15)

d. Reassembly

Perform the installation in the reverse order of the removal.

16-8 STARTER LIGHTING IGNITION SWITCH

a. Description

The starter lighting ignition switch is incorporated in the right handle bracket. (Fig. 16-16)

b. Disassembly

1. Loosen the two switch mounting screws and separate the switch bracket at the right of the handle bar.
2. Disconnect the throttle cable from the throttle control and then remove the throttle cable connector from the switch lower side. (Fig. 16-17)
3. Disconnect the wiring within the headlight case and remove the switch assembly.

c. Inspection

1. Check to make sure that the respective switch positions are functioning properly.

16-9 TURN SIGNAL LIGHT/ HORN SWITCH

a. Description

The turn signal light/horn switch is located on the left handle bar adjacent to the grip. The upper switch is the turn signal light switch and the lower is the horn button switch. (Fig. 16-18)

b. Disassembly

1. Remove the headlight unit and disconnect the wiring within the headlight case.
2. Unscrew the two switch mounting screws and disassemble the switch upper and lower halves.

c. Inspection

1. Turn the main key switch to the on position and set the turn signal control switch to the L position. The turn signal lights on the left side should be flashing and when the switch to the R position the right hand turn signal lights should be flashing.
2. Set the main key switch to the on position and when the horn button is pressed, the horn should operate.

d. Reassembly

Perform the reassembly in the reverse order of disassembly.

Note: When assembling the switch lower half on the handle, make sure that the pin is inserted into the handle bar stopper hole and then tighten together with the switch upper half.

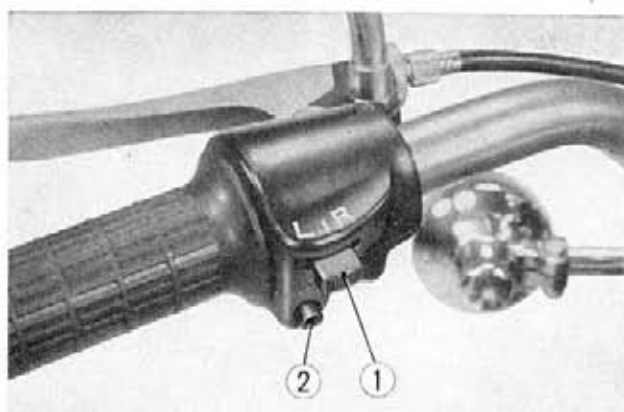


Fig. 16-18 ① Turn signal switch ② Horn button

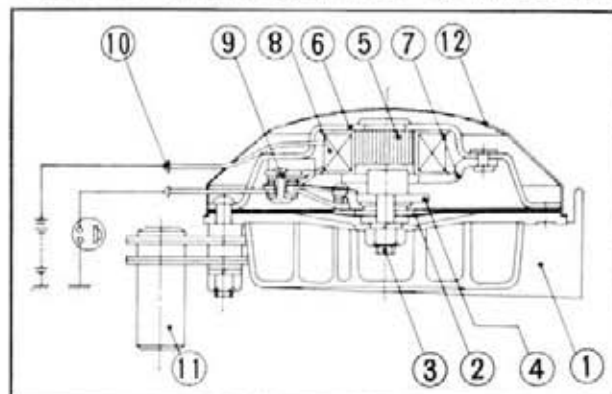


Fig. 16-19 ① Curling horn ⑦ Core plate
② Diaphragm ⑧ Coil
③ Pole B ⑨ Contact assembly
④ Armature ⑩ Coupler (black)
⑤ Pole A ⑪ Horn clamp
⑥ Case ⑫ Cover

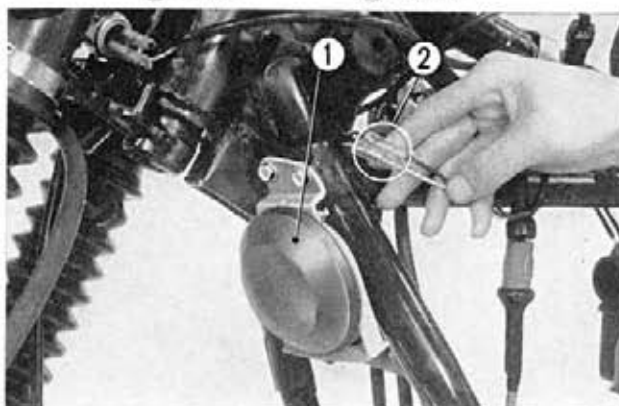


Fig. 16-20 ① Horn ② Lead connectors

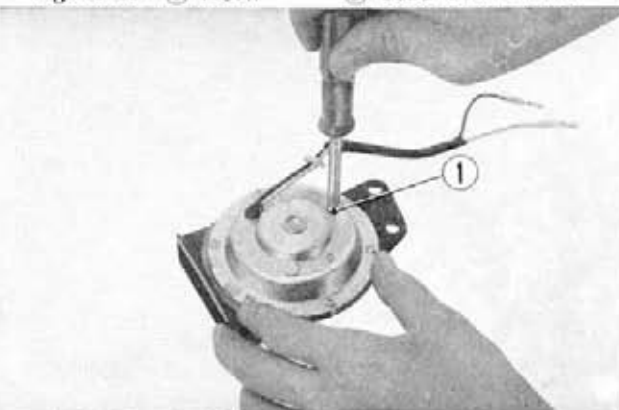


Fig. 16-21 ① Adjusting screw

16-10 HORN

a. Description

The horn is of a curling type. The action of the electronic magnet within the horn sets up the specified vibrating frequency of a metal diaphragm and this produces the sound.

The construction of the horn is shown in (Fig. 16-19).

b. Disassembly

1. Disconnect the electrical leads. (Fig. 16-20)
2. Remove the horn by unscrewing the two bolts from the frame. (Fig. 16-20)

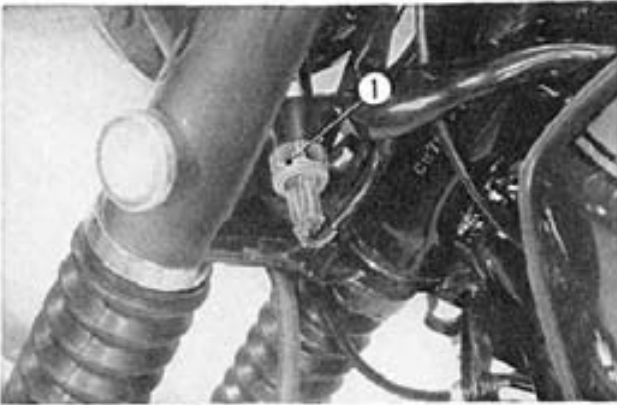


Fig. 16-22 ① Stop switch

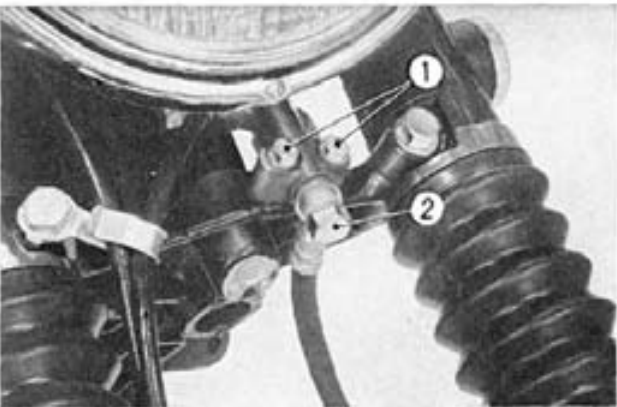


Fig. 16-23 ① Joint mounting bolt
② Joint bolt

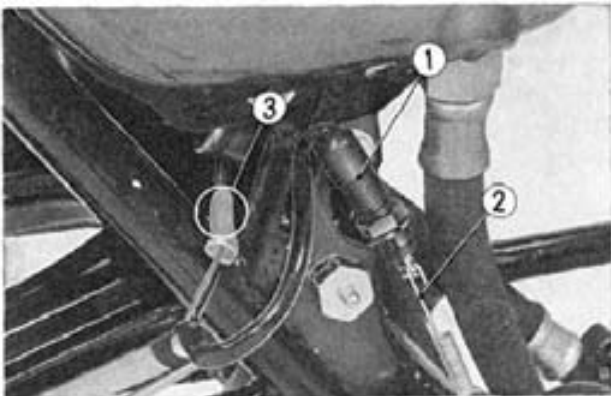


Fig. 16-24 ① Stop light switch
② Stop switch spring
③ Leads connectors

Note: The horn is accurately adjusted to produce the desired sound, therefore, the horn should not be disassembled if it is operating properly.

c. Inspection

If there is a change in pitch of the sound or if the loudness has decreased, check the horn by connecting it to a fully charged battery. If the quality of the sound is still poor, remove the horn cover and adjust by turning the adjusting screw. Turning the screw to the right will increase the loudness.

(Fig. 16-21)

d. Reassembly

Perform the reassembly in the reverse order of disassembly.

16-11 STOP SWITCH (FRONT)

a. Description

The front switch is actuated by the brake oil pressure and is located at the brake hose joint. (Fig. 16-22)

b. Disassembly

1. Remove the electrical leads from the front stop switch.
2. Loosen the joint mounting bolts and remove the front stop switch from the joint. (Fig. 16-23)

c. Inspection

1. Check to make sure that the stoplight is on when the front brake lever is applied, if the light will not be on the stop switch should be replaced.

d. Reassembly

Perform the reassembly in the reverse order of the disassembly.

16-12 STOP SWITCH (REAR)

a. Description

The stoplight switch is a pull type switch operated by the brake pedal. (Fig. 16-24)

b. Disassembly

Disconnect the wiring and remove the stoplight switch from the bracket.

c. Inspection

1. Adjusting the position of the stoplight switch operation. (Fig. 16-24)

- a. First, check the adjustment of the rear brake pedal in accordance with the procedure on page 149 to make sure that the brakes are properly adjusted.
- b. Turn on the main key switch (main key switch position "red" dot).
- c. Adjust the stoplight switch so that the stoplight will come on when the brake pedal is depressed to the point where the brake just starts to take hold. If the stoplight switch is late in switching on the stoplight, screw in the switch lock nut, and if the stoplight comes on too early, screw out the switch lock nut.
- d. **Reassembly**
Perform the reassembly in the reverse order of the disassembly.

16-13 OIL PRESSURE SWITCH

a. Description

The oil pressure switch is mounted on the upper crankcase behind the cylinder. When the oil pressure is over 56.9~85.3 lbs/in² (4~6 kg/cm²), the switch operates.

b. Disassembly

1. Remove the oil pressure switch from the upper crankcase. (Fig. 16-25)
2. Disconnect the electrical lead.

c. Inspection

The oil pressure warning lamp does not come on when the main key switch is switched on or the lamp does not go off when the engine is started, it is indication that the oil pressure switch is defective.

d. Reassembly

Perform the installation in the reverse order of the removal.

16-14 NEUTRAL SWITCH

a. Description

The neutral switch is mounted under the lower crankcase.

This switch operates the neutral indicator lamp located on the tachometer.

b. Disassembly

1. Unscrew the neutral switch screw and disconnect the electrical lead.
2. Remove the neutral switch mounting bolt from the lower crankcase and remove the neutral switch. (Fig. 16-26)

c. Inspection

1. Check to make sure that the green neutral pilot lamp comes on when the gear is shifted into the neutral position by the gear change pedal.
2. Check the operation and condition of the neutral switch.

d. Reassembly

Perform the installation in the reverse order of the removal.

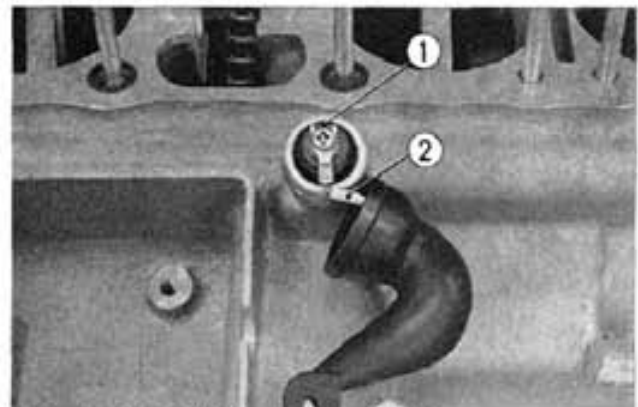


Fig. 16-25 ① Oil pressure switch
② Electrical lead

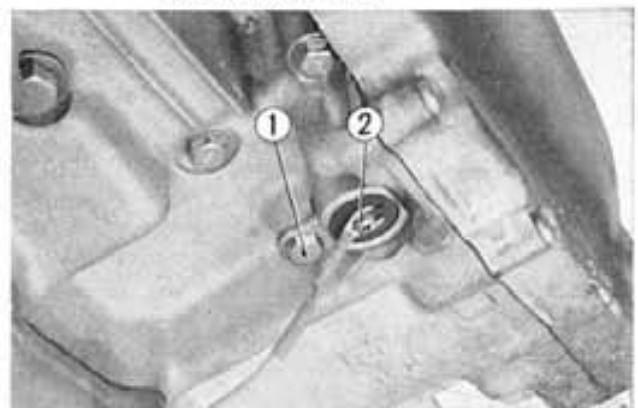


Fig. 16-26 ① Neutral switch mounting bolt
② Neutral switch

16-15 WIRE HARNESS

a. Description

The respective circuits in the wire harness are coded with different colors to make it easy to service electrical system.

b. Disassembly

1. Open the seat and remove the fuel tank.
2. Remove the headlight and disconnect the leads installed of the inside of the head light case.

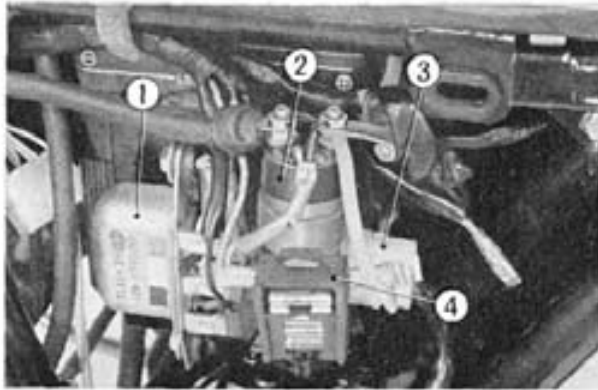


Fig. 16-27 ① Regulator
② Starter magnetic switch
③ Rectifier connector
④ Fuse case

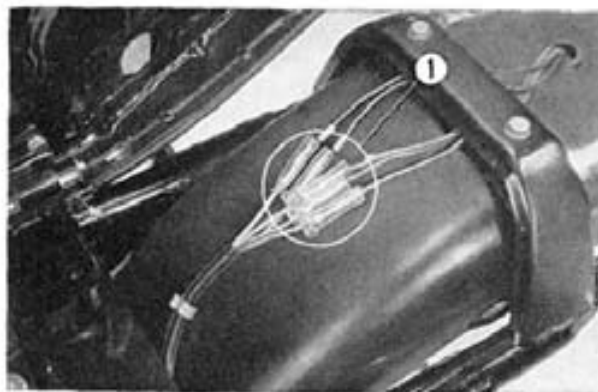


Fig. 16-28 ① Electric leads

3. Disconnect the ignition coil leads.
4. Disconnect the horn leads.
5. Disconnect the front stop switch leads.
6. Disconnect the main key switch leads.
7. Disconnect the generator connector.
8. Disconnect the contact breaker/stop switch leads.
9. Remove the battery cover, and then remove the following parts; regulator, starter magnetic switch, rectifier connector, fuse case and signal stat. (Fig. 16-27)
10. Remove the leads on the rear fender. (Fig. 16-28)
11. Remove the wire harness bands, and then remove the wire harness from the frame.

c. Inspection

1. Perform the continuity test for each socket connected wire leads in the same color. (Fig. 16-29)
2. If the wire harness tape is torn or deteriorated, replace it.

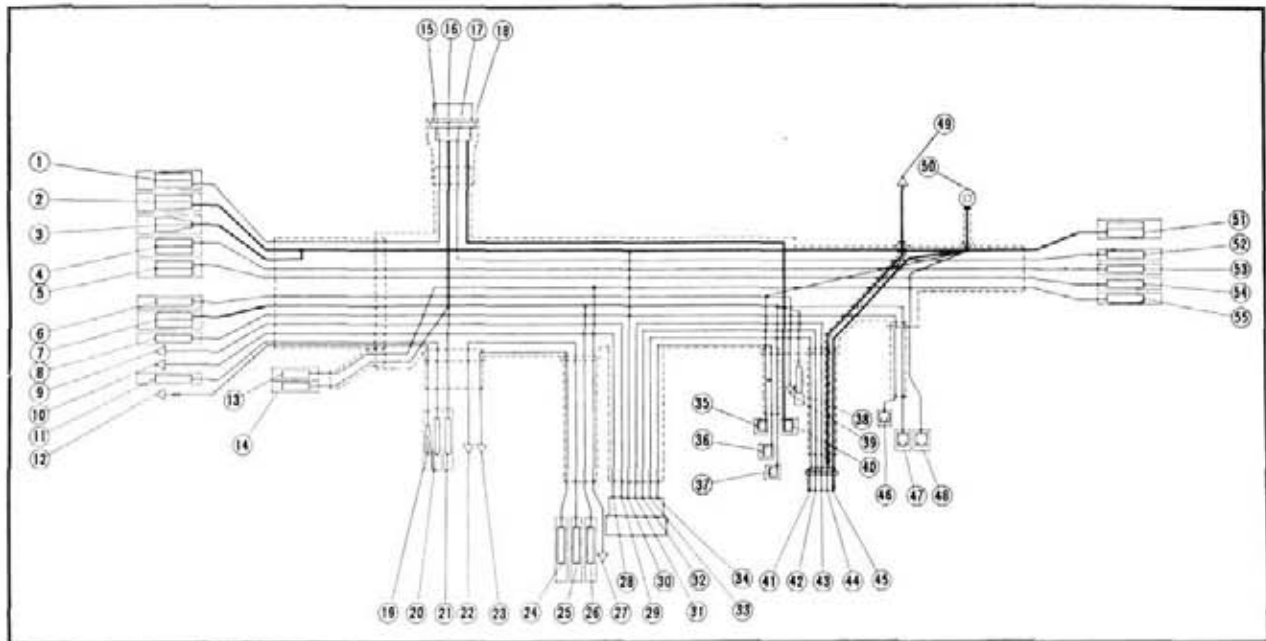


Fig. 16-29

| No. | Lead color | Connection | No. | Lead color | Connection |
|-----|-------------------|---|-----|-----------------|------------------------------------|
| ① | Brown/White | Speedometer lamp, Beam selector switch, Tachometer lamp | ②④ | Yellow | Contact breaker |
| ② | Green | Headlight, Speedometer, Tachometer | ②⑤ | Blue | " |
| ③ | Green | R. L front turn signal light | ②⑥ | Black | " |
| ④ | Light blue | R. front turn signal light, starter switch, turn signal pilot lamp | ②⑦ | Green/Yellow | Stop switch |
| ⑤ | Orange | Turn signal pilot lamp, L. front turn single light, Starter/turn signal switch | ②⑧ | Light green/Red | Neutral switch |
| ⑥ | Yellow/Red | Starter/turn signal switch | ②⑨ | Blue/Red | Oil pressure switch |
| ⑦ | Black | Neutral pilot lamp, Oil pressure lamp, Head light beam selector switch, ignition switch | ③① | Yellow | A. C generator |
| ⑧ | Grey (white tube) | Starter switch, Turn signal switch | ③② | " | " |
| ⑨ | Blue/Red | Oil pressure lamp | ③③ | " | " |
| ⑩ | Light green/Red | Neutral pilot lamp | ③④ | White | " |
| ⑪ | Light green | Horn switch, Beam selector switch | ③⑤ | Green | Regulator |
| ⑫ | Black/White | Ignition switch | ③⑥ | White | " |
| ⑬ | Green/Yellow | Front stop switch | ③⑦ | Black | " |
| ⑭ | Black | Front stop switch | ③⑧ | Black | Starter magnetic switch |
| ⑮ | Brown/White | Main key switch | ③⑨ | Yellow/Red | " |
| ⑯ | Black | " | ④① | Red | Fuse |
| ⑰ | Brown | " | ④② | Yellow | Silicon rectifier |
| ⑱ | Red | " | ④③ | " | " |
| ⑲ | Black/White | Ignition coil | ④④ | " | " |
| ⑳ | Light green | Horn | ④⑤ | Red/White | " |
| ㉑ | Black | Horn. ignition coil | ④⑥ | Green | " |
| ㉒ | Blue | Ignition coil | ④⑦ | Grey | Winker relay |
| ㉓ | Yellow | Ignition coil | ④⑧ | Black | " |
| | | | ④⑨ | Green | " |
| | | | ④⑩ | Red/White | Starter magnetic switch |
| | | | ⑤① | Green | Frame body |
| | | | ⑤② | Green | Tail/stop light, turn signal light |
| | | | ⑤③ | Brown | Tail light |
| | | | ⑤④ | Light blue | R. rear turn signal light |
| | | | ⑤⑤ | Orange | L. rear turn signal light |
| | | | | Green/Yellow | Stop light |

d. Reassembly

Perform the reassembly in the reverse order of disassembly by connecting each lead correctly in place. (Fig. 16-30)

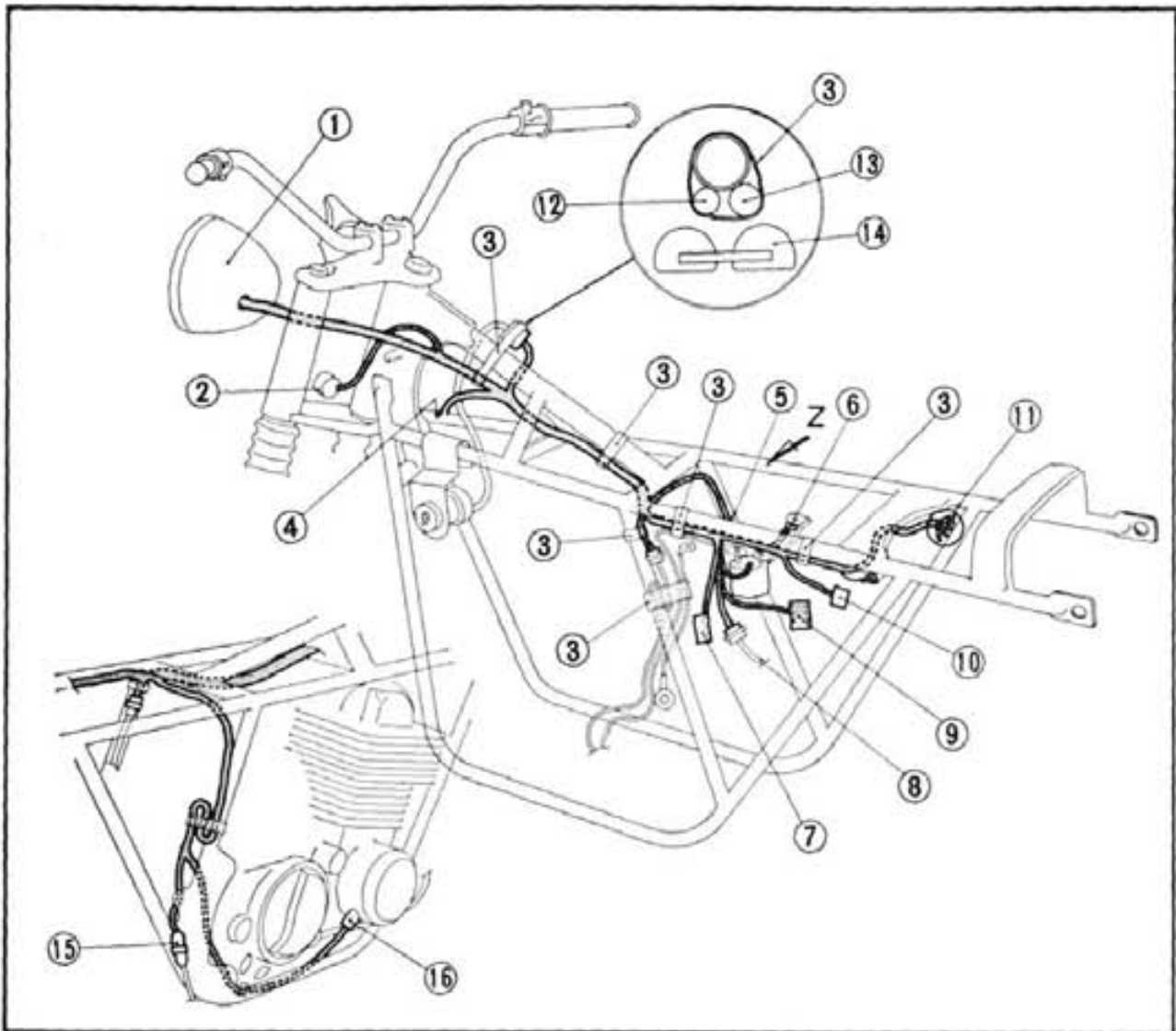


Fig. 16-30

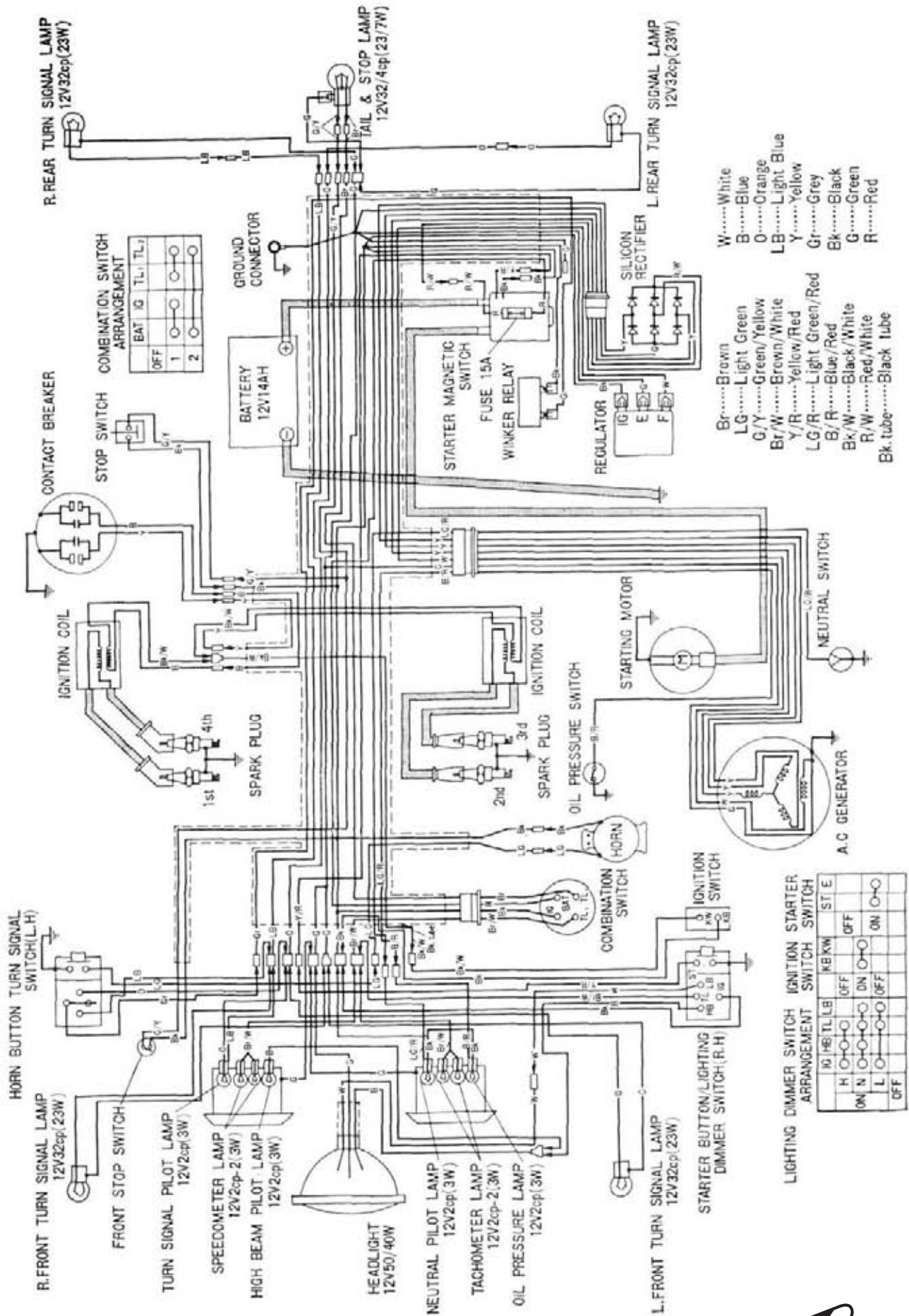
- | | |
|--------------------------------------|--|
| ① Headlight | ⑨ To fuse |
| ② Stop switch (front) | ⑩ To flasher relay |
| ③ Wire harness band | ⑪ To tail/stop light and turn signal light |
| ④ To horn and ignition coil | ⑫ Wire harness |
| ⑤ To stop switch and contact breaker | ⑬ Main key switch coupler |
| ⑥ To battery | ⑭ Ignition coil |
| ⑦ To regulator | ⑮ Stop switch (rear) |
| ⑧ To rectifier | ⑯ To contact breaker points |

WIRING DIAGRAM

GROUP

17







ENGINE TUNE-UP

GROUP

18

CONTENTS

| | |
|--|-----|
| 1. COMPRESSION TEST | 173 |
| 2. SERVICE SPARK PLUGS | 174 |
| 3. CHECK AND ADJUST IGNITION TIMING..... | 174 |
| 4. SERVICE BATTERY | 174 |
| 5. ADJUST VALVE TAPPET CLEARANCE | 174 |
| 6. ADJUST CAM CHAIN | 174 |
| 7. SERVICE AIR CLEANER | 174 |
| 8. CHECK AND SERVICE FUEL SYSTEM | 174 |
| 9. ADJUST CARBURETOR | 174 |
| 10. CHANGE OIL AND OIL FILTER..... | 174 |
| 11. ROAD TEST..... | 174 |

The engine tune-up referred herein is the diagnosis for the determination of the cause of the engine malfunction, lack of power or abnormal fuel consumption, and the maintenance and servicing task to adjust the engine to its best operating condition. The processes described below is confined within the scope of preventive maintenance operation and does not constitute an overhaul or disassembling. It is recommended that the sequence of operation outlined below be followed when performing the tune-up.

The engine tune-up operations are basically a part of the periodical maintenance except compressions test of engine. Therefore, for the operations other than the compression test and road test, refer to the pertinent part of the Group of Periodical Maintenance.

1. COMPRESSION TEST

Before a tune-up is performed, the engine must be in a condition suitable for tuning up. This can be determined by first checking the compression of each cylinder to assure that the compression pressure is normal. This test is conducted with the engine properly serviced with engine oil and warmed up to operating temperature, and then following the procedure below.

- a. Remove all the spark plugs from the cylinder head. After the spark plug has been removed, carefully clean the areas around the spark plug hole and seat to remove any dirt and grease.
- b. Insert the end of the compression gauge into the spark plug hole and make sure that it is properly seated.

- c. Twist the throttle grip so that the throttle is at maximum opening, and set the carburetor choke valves to full opened.
- d. Crank the engine with the starter motor and record the highest pressure indicated on the compression gauge. (Fig. 18-1)

Perform this test for each of the cylinders.

The normal compression pressure is 150 psi (10.5 kg/sq. cm)~170 psi (12 kg/sq. cm)

If the compression pressure varies by more than 10% between the highest and lowest cylinders or if the pressure of any cylinder is lower than normal, it is an indication that there is a probable defect in the engine, such as worn or broken piston rings, poor valve seating or leaking head gaskets. The defect must be corrected before attempt is made to tune-up.

Refer to page 33~35 for repair procedures.



Fig. 18-1 ① Compression gauge

2. SERVICE SPARK PLUGS..... (Refer to page 179)
3. CHECK AND ADJUST IGNITION TIMING..... (Refer to page 180)
4. SERVICE BATTERY..... (Refer to page 184)
5. ADJUST VALVE TAPPET CLEARANCE..... (Refer to page 181)
6. ADJUST CAM CHAIN..... (Refer to page 181)
7. SERVICE AIR CLEANER..... (Refer to page 181)
8. CHECK AND SERVICE FUEL SYSTEM..... (Refer to page 181)
9. ADJUST CARBURETOR..... (Refer to page 182)
10. CHANGE OIL AND OIL FILTER..... (Refer to page 178)
11. ROAD TEST

After completing the initial series of the tune-up, start the engine in the normal manner. Ride the motorcycle and conduct the road test to check the starting, acceleration, and also for stable riding at low and intermediate speeds. If possible ride the motorcycle at high speed and also check for mis-fire during acceleration and deceleration and during rough riding; flat spot during acceleration. If the results of the test are not completely satisfactory, the trouble diagnosis of the engine, clutch and brake should also be performed.

PERIODICAL MAINTENANCE

GROUP
19

CONTENTS

| | |
|--|-----|
| MAINTENANCE SCHEDULE | 175 |
| MAINTENANCE OPERATION..... | 178 |
| 1. Change engine oil | 178 |
| 2. Change oil filter element..... | 178 |
| 3. Clean oil pump strainer | 179 |
| 4. Check engine oil pressure | 179 |
| 5. Service spark plug..... | 179 |
| 6. Check and adjust ignition system | 180 |
| 7. Adjust valve tappet clearance..... | 181 |
| 8. Adjust cam chain | 181 |
| 9. Service air cleaner..... | 181 |
| 10. Check and service fuel line and fuel valve | 181 |
| 11. Adjust carburetor | 182 |
| 12. Oil tank and oil filter servicing | 182 |
| 13. Check and adjust clutch..... | 183 |
| 14. Service battery..... | 184 |
| 15. Check and service front suspension | 184 |
| 16. Check and service rear suspension | 185 |
| 17. Check front and rear wheels and tires | 185 |
| 18. Check and service brakes..... | 185 |
| 19. Check and service drive chain and sprockets | 186 |
| 20. Check components of the body | 187 |
| 21. Check and adjust lights, horn and instruments..... | 187 |

MAINTENANCE SCHEDULE

The following maintenance schedule is based upon average riding conditions.

Machines subjected to severe use, or ridden in unusually dusty areas, require more frequent servicing.

| | INITIAL SERVICE PERIOD | REGULAR SERVICE PERIOD Perform at every indicated month or mileage interval, whichever occurs first. | | | |
|---|------------------------|---|-------------|-------------|-------------|
| | 500 miles | 1 month | 3 months | 6 months | 12 months |
| | | 500 miles | 1,500 miles | 3,000 miles | 6,000 miles |
| ENGINE OIL—Change | ● | | ○ | | |
| OIL FILTER ELEMENT—Replace | ● | | | ○ | |
| OIL FILTER SCREEN—Clean | | | | | ○ |
| SPARK PLUGS—Clean and adjust gap or replace if necessary. | | | | ○ | |
| *CONTACT POINTS AND IGNITION TIMING—Clean, check, and adjust or replace if necessary. | ● | | | ○ | |
| *VALVE TAPPET CLEARANCE—Check, and adjust if necessary. | ● | | | ○ | |
| *CAM CHAIN TENSION—Adjust. | ● | | | ○ | |
| PAPER AIR FILTER ELEMENT—Clean. | | (service more frequently if operated in dusty areas) | | ○ | |
| PAPER AIR FILTER ELEMENT—Replace. | | | | | ○ |
| *CARBURETORS—Check, and adjust if necessary. | ● | | | ○ | |
| THROTTLE OPERATION—Inspect cables. Check, and adjust free play. | ● | | | ○ | |
| FUEL FILTER SCREEN—Clean. | | | | ○ | |
| FUEL LINES—Check. | | | | ○ | |
| *CLUTCH—Check operation, and adjust if necessary. | ● | | | ○ | |
| DRIVE CHAIN—Check, lubricate, and adjust if necessary. | **● | ○ | | | |
| BRAKE FLUID LEVEL—Check, and add fluid if necessary. | ● | | | ○ | |

| | INITIAL SERVICE PERIOD | REGULAR SERVICE PERIOD Perform at every indicated month or mileage interval, whichever occurs first. | | | |
|---|------------------------|---|-------------|-------------|-------------|
| | 500 miles | 1 month | 3 months | 6 months | 12 months |
| | | 500 miles | 1,500 miles | 3,000 miles | 6,000 miles |
| *FRONT BRAKE PADS—Inspect, and replace if worn. | | | | ○ | |
| *REAR BRAKE SHOES—Check wear indicator. | | | | ○ | |
| BRAKE CONTROL LINKAGE—Check linkage, and adjust free play if necessary. | ● | | | ○ | |
| *WHEEL RIMS AND SPOKES—Check. Tighten spokes and true wheels, if necessary. | ● | | | ○ | |
| TIRES—Inspect and check air pressure. | ● | ○ | | | |
| FRONT FORK OIL—Drain and refill. | ***● | | | | ○ |
| FRONT AND REAR SUSPENSION—Check operation. | ● | | | ○ | |
| REAR FORK BUSHING—Grease, check for excessive looseness. | | | | ○ | |
| *STEERING HEAD BEARINGS—Adjust. | | | | | ○ |
| BATTERY—Check electrolyte level, and add water if necessary. | ● | | ○ | | |
| LIGHTING EQUIPMENT—Check and adjust if necessary. | ● | ○ | | | |
| ALL NUTS, BOLTS, AND OTHER FASTENERS—Check security and tighten if necessary. | ● | ○ | | | |

Items marked * should be serviced by an authorized Honda dealer, unless the owner has proper tools and is mechanically proficient. Other maintenance items are simple to perform and may be serviced by the owner.

** INITIAL SERVICE PERIOD 200 MILES

*** INITIAL SERVICE PERIOD 1,500 MILES

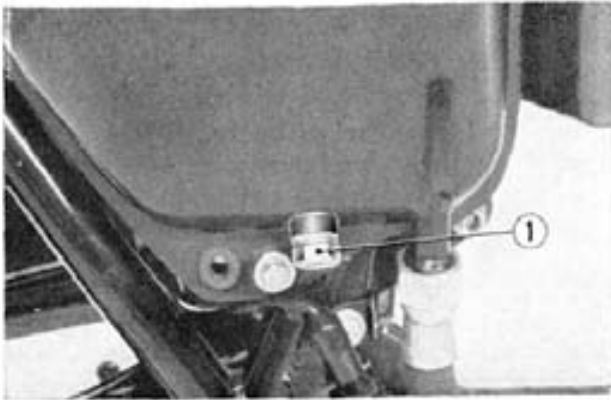


Fig. 19-1 ① Oil tank drain plug

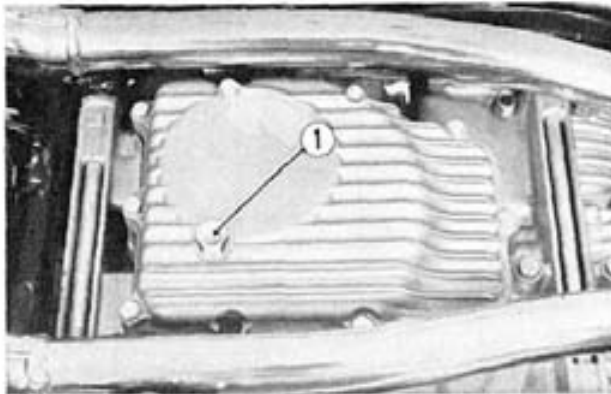


Fig. 19-2 ① Crankcase oil drain plug



Fig. 19-3 ① Oil dipstick ② Upper level line ③ Lower level line

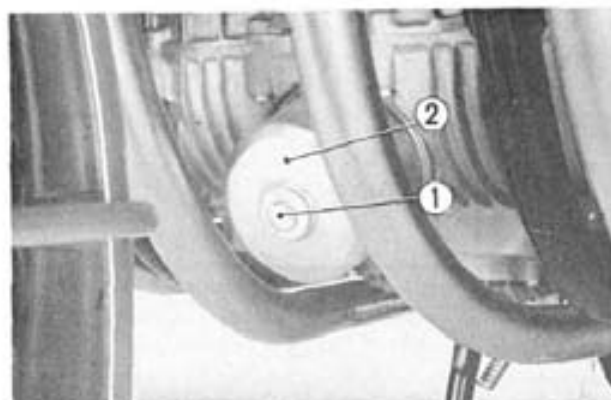


Fig. 19-4 ① Oil filter retaining bolt ② Oil filter cover

MAINTENANCE OPERATION

1. Change engine oil

(1) Take the oil tank cap off and remove the drain plugs from the oil tank and lower crankcase. (Fig. 19-1, 2) The oil will drain steadily. Operate the kick starter several times to drain any oil which may have been left within the pockets of the engine. After the oil has been thoroughly drained, reinstall and tighten the drain plugs.

(2) Add approximately 3.0 qts. (2.9 lit.) of good grade oil of MS, DG or DM, SAE 10W-40 or 20W-50 into the oil tank and start the engine. After making sure that the warning light is off, raise the engine rpm to 1000~1500 and run the engine for one or two minutes.

Stop the engine and check the oil level in the tank with the dipstick on the filler cap (Fig. 19-3) and add oil if necessary to bring the oil to upper level line.

(3) First oil change should be done at 200 miles (300 km) and thereafter oil change should be made at 1500 mile (2500 km) intervals as described in the listed schedule list.

2. Change oil filter element

(1) Remove oil filter cover by unscrewing the oil filter retaining bolt. (Fig. 19-4)

Discard oil filter element and oil filter rubber packing. Clean the oil filter cover and other components with clean gasoline or solvent and dry them before reinstall. Replace the oil filter cover with a new element and rubber packing.

Having installed the filter cover, start the engine and inspect oil seepage.

(2) The oil filter should be changed according to the schedule. However for convenience it should be done when the oil is changed.

3. Clean oil pump strainer

Remove oil pan cover by unscrewing ten bolts (6 mm). Remove the oil pump strainer from the oil pump body and clean the strainer and oil pan cover with solvent. Fit the strainer to the pump body by the rubber clamp.

Attach the cover with a new gasket, and then inspect oil seepage around the cover by starting engine. (Fig. 19-5)

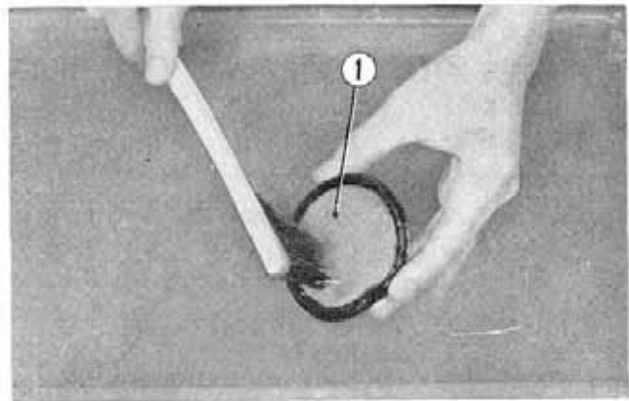


Fig. 19-5 ① Oil strainer

4. Check engine oil pressure

The oil pressure can be checked by removing the oil path cap on the right side of the crankcase and installing a pressure gauge adapter (Tool No. 07510-3000000), pressure gauge (Tool No. 07506-3000000) and running the engine. If the oil pressure is 50 to 64 PSI (3.5~4.5 kg/sq. cm) at approximately 3000 rpm engine speed and the oil temperature at 140°F (60°C), the condition is satisfactory. If the condition is unsatisfactory, refer to the section of Oil Pump on page 60. (Fig. 19-6)

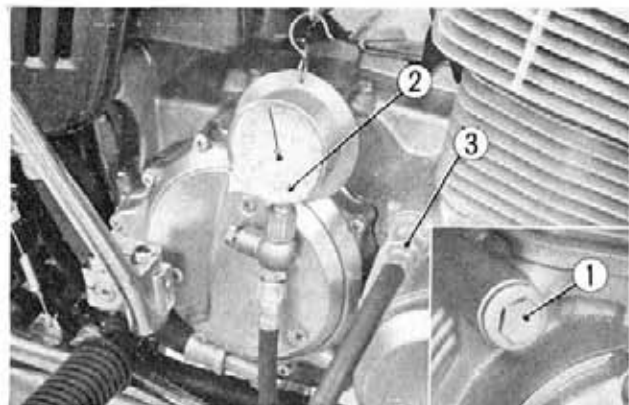


Fig. 19-6 ① Oil path cap ② Oil pressure gauge ③ Adapter

5. Service spark plug

- (1) Remove the spark plugs with spark plug wrench for CB750. The spark plug which was removed must be inspected in detail. If the electrodes are excessively worn, deformed or if the porcelain is broken, the plug must be replaced. Inspect each spark plug for make and heat range. All plugs must be of same make and suitable heat range.
- (2) The spark plug which is satisfactory for reuse should be cleaned with a spark plug cleaner. If a spark plug cleaner is not available, use wire brush or a stiff pointed wire to remove any carbon deposits from the electrodes and also from around the tip of the porcelain insulator; followed by washing it thoroughly in solvent and then drying with a rag.
- (3) If necessary, adjust the gap to a standard value of 0.024~0.028 in. (0.6~0.7 mm) by bending the ground electrode. Check the electrodes gap with a thickness gauge.
- (4) If a spark plug tester is available, the plug should be tested to assure that its condition is satisfactory. Any plug that is found to be poor in performance should be replaced.
- (5) Use the spark plug wrench to install the plug. Insert the plug into the wrench socket, position the threaded end of the plug squarely against the spark plug hole to prevent cross-threading and carefully screw the plug into the hole by turning the socket by hand until finger tight. Complete tightening by attaching the bar handle on the plug wrench and torque 1/2~3/4 turn.

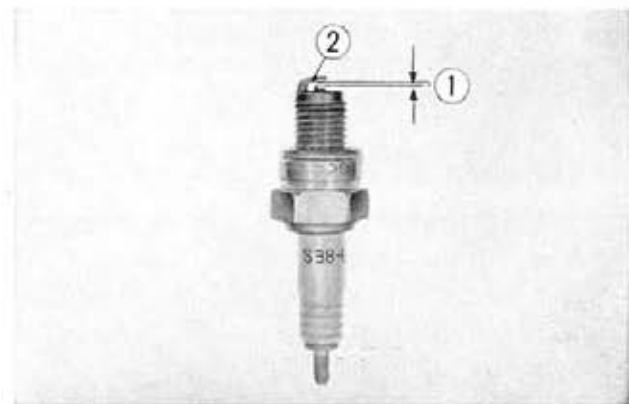


Fig. 19-7 ① Spark plug gap ② Ground electrode

Caution :

- A plug which is cross-threaded into the plug hole will be hard to turn, attempt to forcibly screw in the plug will cause damage to the cylinder head.
- Refrain from over-torquing the spark plug as this will result in a change to the spark gap and also make it difficult to remove the plug.
- Do not forget to install the spark plug washer.
- Do not attempt to dry or remove soot from the plug by burning.

6. Check and adjust ignition system

- (1) Inspect the condition of the spark plug wiring and plug cap. Replace any wire showing signs of aging which is noted by cracks or by wear ; also replace any plug cap which is broken.
- (2) Inspect in detail the wiring and connectors of other ignition components such as the ignition coil, high tension cords, breaker point contacts, and replace any items found to be defective. Tighten any loose terminals.

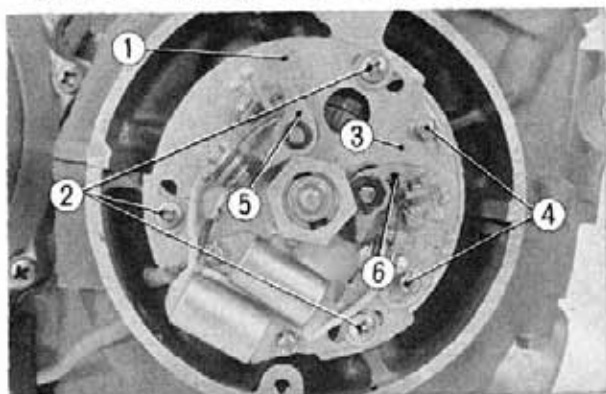


Fig. 19-8 ① Contact breaker assembly
 ② Base plate setting screws
 ③ Right base plate
 ④ Right base plate setting screws
 ⑤ 1.4 cylinder breaker points
 ⑥ 2.3 cylinder breaker points

- (3) Inspect the breaker point contact surfaces. Remove the contact breaker point cover from the right side of the crankcase, turn the crankshaft in the clockwise direction until one set of breaker points is at maximum opening (point arm slipper resting on the peak of the cam lobe) and then check the condition of the point surfaces. The points may be further opened by a finger to enable better inspection. Do not force to open excessively, otherwise it may damage the point spring.

If the point surfaces are dirty or coated with grease, wipe off with a clean dry rag.

If the point surfaces are discolored and

slightly become roughness, or pitted, use a point file to remove any metal built-up or scales and then wipe clean with a dry rag. Do not use any emery or sandpaper to clean the surfaces as the dust will become lodged between the points and cause trouble.

When the point surfaces are excessively burnt or deeply pitted, rather than dressing down the surfaces with a point file or an oil stone to obtain a smooth surface, replace the points in set. Further, a diagnosis should be conducted to determine the cause of this problem and corrected to prevent its reoccurrence. (Refer to page 90)

- (4) Inspect and adjust breaker point gap. Measure the point gap with a flat ended thickness gauge when the opening is at its maximum. The standard gap is 0.012~0.016 in. (0.3~0.4 mm). If the gap is not in the limit, adjust it in accordance with the proper method. (Refer to page 90)
- (5) Inspect point cam lubrication. If the cam lobe oiling felt is dried supply a drop of engine oil by oil can. Do not lubricate too much or drop oil to other part of the contact breaker.
- (6) Inspect and adjust ignition timing. If the timing light is available, check the ignition timing and the spark advance under engine operating condition. Ignition timing can also be checked statically by the use of the continuity timing light or by visually observing the timing marks to determine the instant when the breaker points open. Replace the contact breaker point cover and tighten screws securely. As the ignition timing will

affect to the engine performance, a precise adjustment is required when the timing is off from the standard setting. For adjustment refer to timing adjustment. (Refer to page 85~86)

- (7) Observe the contact points while the engine is running and if a spark through the points is notable, test the condenser for capacity and insulating resistance. (Refer to page 90) Replace the condenser when it is unserviceable.

7. Adjust valve tappet clearance

Drain the remaining gasoline from the tank or turn the tank valve to the OFF position and plug up the outlets of fuel lines to prevent gasoline from leaking. Remove the fuel tank, contact breaker point cover and tappet hole caps.

Use a thickness gauge and measure the valve tappet clearance. The **inlet valve should be 0.02 in (0.05 mm) and the exhaust valve 0.003 in (0.08 mm)**. If any adjustment is required, do not forget to tighten the tappet adjusting screw lock nut after the adjustment is completed. (Refer to page 42~43)

The rubber gaskets for the tappet inspection holes cap should be replaced with new items.

8. Adjust cam chain

Perform the cam chain adjustment in accordance with the procedures outlined on page 38. Adjustment is made by loosening the tensioner lock nut and lock bolt, this will allow the tensioner applying proper tension to the cam chain. Tighten the lock bolt and nut to complete adjustment.

Caution:

Do not apply additional pressure on the tensioner push bar.

9. Service air cleaner

Remove the air cleaner and perform dusting in the following manner.

- (1) Remove left side cover and remove the air cleaner lower case by loosening the wing nuts.
- (2) Remove the air cleaner element and clean it by tapping lightly to loosen dust then using a soft brush, the remaining dust can be brushed from the outer element surface or apply compressed air from the inside of the element. (Fig. 19-9)
- (3) Install the air cleaner lower case.

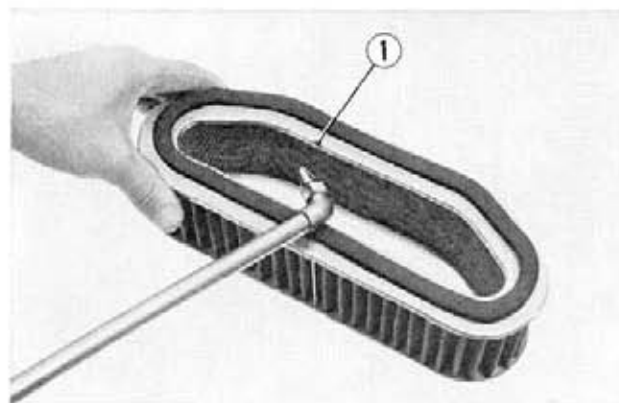


Fig. 19-9 ① Air cleaner element

10. Check and service fuel line and fuel valve

- (1) Check the vent hole in the fuel tank cap to make sure that it is not clogged or restricting the free flow of air; in which case the vent hole should be cleaned or the cap gasket be replaced. The fuel tank and the fuel tube leading from the tank to the carburetor should be inspected for fuel leaks, sharp bend or kink in the fuel tube, or loosening of the tube clips.
- (2) Check the operation of the fuel valve by positioning the cock lever to the OFF position, disconnecting the fuel tube at the carburetor, and then positioning the cock lever to the ON and RES position to make sure that there is fuel flow in both positions. If there is insufficient flow in either of the position, check the valve packing or other

valve components which may be causing the trouble and make the repair. Further, if there is fuel leak with the lever in the stop position, the valve packing is defective and should be replaced.

Caution: Whenever fuel has been spilled on the engine, it should be completely wiped off before starting the engine, or else, there may be possibility of a fire.

- (3) Remove the fuel valve strainer cup and clean the strainer and cup with gasoline. If it is necessary to replace the strainer, the gasket should also be replaced. Tighten the strainer cup properly. When cleaning the strainer or when checking the valve for fuel flow, the fuel should not be permitted to spill on the floor but, rather, should be caught in some type of vessel so as not to create a fire hazard condition.

11. Adjust carburetor

- (1) Operate the choke valve through the full operating range and check its condition. If there is any unsatisfactory condition, the cause should be determined and corrected. Next, start the engine and with it operating at idle speed, close the choke valve fully; if the engine does not stall out, the choke rod for the respective carburetors should be adjusted so that the choke valves are fully closed. (Refer to page 78)

To adjust the choke valve precisely, disconnect the fuel tank and the carburetor connecting tube, peep into the inlet port and check the clearance between choke valve and venturi when the choke valve is fully closed. The clearance should be 0.02 in (0.5 mm).

- (2) Start the engine and allow to warm up for several minutes. Then check to see if the idling speed is 850–950 RPM with the tachometer relatively stable. If the speed is not within this range, make the adjustment with the throttle stop screws by turning all four screws equally within the range of 1/4 turn clockwise to increase speed. (Refer to page 78–80)
- (3) Next, connect the vacuum gauge to each of the four carburetors and measure the vacuum pressure during idle speed. The pressure indications should be uniformly within the range of 20–22 cm HG and the gauge needle should not swing excessively. If adjustment is necessary, it is performed with the pilot air screw and the throttle stop screw.

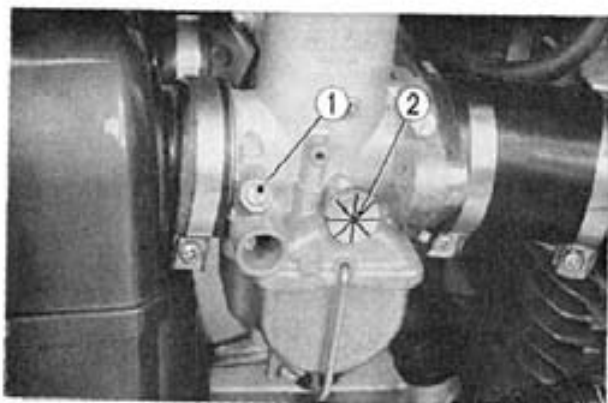


Fig. 19-10 ① Air screw
② Throttle stop screw

(Fig. 19-10)

If in case where the vacuum gauge is not available, listen to the exhaust noise while slowly twisting the throttle grip to open throttle valve (approximately 1/4 turn). If the noise is random or popping, adjust the air screws to synchronize exhaust pressure of each of the cylinder by placing a hand at the exhaust outlet. (Refer to page 80–81)

- (4) Operate the throttle grip slowly and then rapidly for both accelerating to assure that the engine response is smooth. Also, perform the same check with the handle turned fully to both the right and left. If the condition is not normal, the problem is probably in the routing of the throttle cable or in its adjustment and should be corrected after the cause has been determined.

The standard throttle grip play is 10° to 15°. Adjust the throttle grip play at the throttle wire.

The standard throttle grip play is 10° to 15°. Adjust the throttle grip play at the throttle wire.

12. Oil tank and oil filter servicing

- (1) The engine oil and the oil filter are replaced at the specified intervals. Check the oil

condition frequently and the filter during the oil change period and if it is found to require replacement at short intervals, then the change intervals should be made as necessary to suite the condition. (Refer to page 178).

- (2) Check the oil level in the oil tank and if it is found to be low, the oil should be replenished with that of the specified grade.
- (3) Check the oil pressure by removing the oil path bolt located on the right side of the crankcase, and install the pressure gauge. Operate the engine at 3,000 rpm and when the engine has attained the operating temperature, take the pressure reading. The pressure indication should be 50-64 PSI (3.4-4.5 kg/sp. cm). If the pressure is not normal, the cause of the trouble must be determined and corrected.

13. Check and adjust clutch

- (1) Start the engine

Pull in the clutch lever and shift into low gear and check that the engine does not stall, nor the motorcycle starts to creep. Gradually release the clutch lever and open the throttle, and check that the motorcycle should start smoothly and gradually accelerate without slippage. If any trouble is found first adjust the clutch properly before proceeding further check.

- (2) To adjust, perform the following steps.

- a. Screw the clutch cable adjusting bolt ①, located at the clutch lever, all the way into the clutch lever bracket. (Fig. 19-11)
 - b. Turn the clutch cable adjusting bolt located at the clutch housing, in the direction ① to loosen the clutch cable. (Fig. 19-12)
 - c. Remove the clutch cover, loosen the clutch lifter adjusting screw lock nut, turn the clutch adjusting screw in the clockwise direction until a slight resistance is felt. From this position, turn the adjusting screw in the counter clockwise direction 1/4~1/2 turn. Tighten the lock nut. (Fig. 19-13)
 - d. Turn the clutch cable adjusting bolt located at the clutch housing lower right side of the engine in the ② direction so that there is approximately 3/4 of free play at the clutch lever; then tighten the lock nut. (Fig. 19-12)
 - e. The remaining clutch lever free play is obtained by the clutch cable adjusting bolt.
- (3) The nominal clutch lever free play is 0.4-1.0 in (10~25 mm) measured at lever end before the clutch starts to disengage.

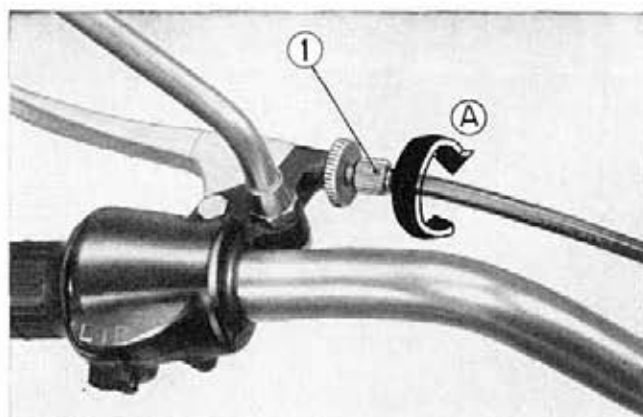


Fig. 19-11 ① Clutch cable adjusting bolt

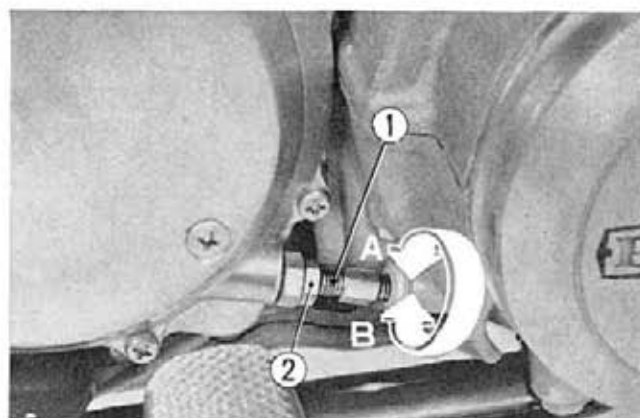


Fig. 19-12 ① Clutch cable adjusting bolt
② Lock nut

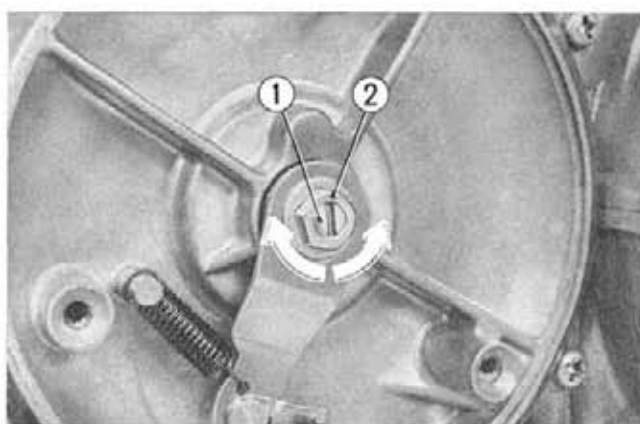


Fig. 19-13 ① Clutch adjusting screw
② Lock nut

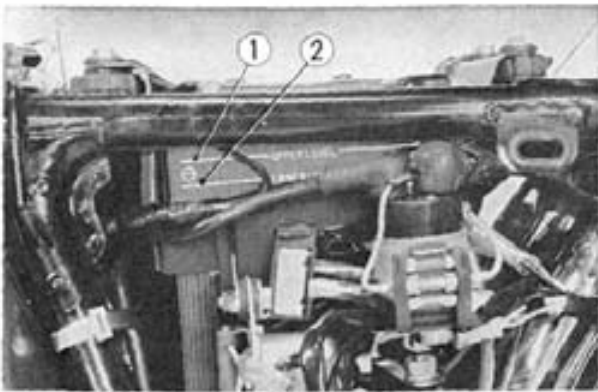


Fig. 19-14 ① Upper level mark
② Lower level mark

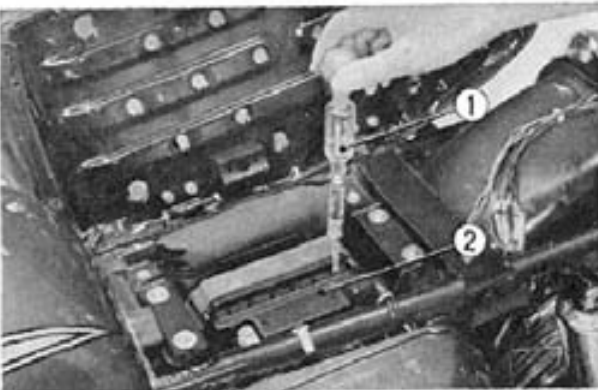


Fig. 19-15 ① Hydrometer
② Battery

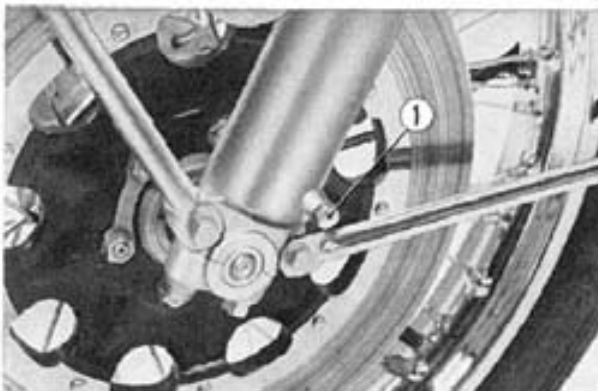


Fig. 19-16 ① Front fork drain plug

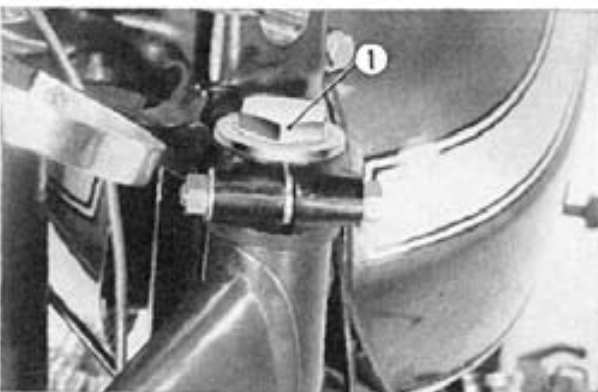


Fig. 19-17 ① Top filler plug

14. Service battery

- (1) Remove the left cover by pulling free of the rubber mounts and by raising the seat. Observe the electrolyte level from the left side at the motorcycle. If it is necessary add distilled water carefully to bring the electrolyte level of the cells between the lower and upper marks. (Fig. 19-14)
- (2) Remove the battery cell caps and check electrolyte specific gravity in each cell with a hydrometer. (Fig. 19-15)

If specific gravity reading drops below 1.200 at 68°F (20°C) the battery should be charged at a rate not to exceed 4.2Amps, until the reading becomes between 1.260 and 1.280 at 68°F (20°C).

- (3) Connect the voltmeter leads to the battery terminals, and measure the voltage. If the voltage is less than 12V after correcting to 77°F (25°C) electrolyte temperature the battery should be thoroughly checked and the problem diagnosed.

The correction of voltage to 77°F (25°C) should be based on the following formula.

$$V(77^{\circ}\text{F}) = Vt + 0.0378(t - 77)$$

$$V(25^{\circ}\text{C}) = Vt + 0.0378(t - 25)$$

(V: measured value of voltage, t: average electrolyte temperature of all cells)

Based on the result of the battery test, determination should be made whether the generator and the regulator requires testing. If the condition of the battery tests satisfactory, it will not necessary to check charging system during tune-up.

- (4) Inspect the condition of the both positive and negative battery terminals, positive terminal rubber cap, battery vent tube and the rubber band of the battery retainer, and if any of the items are defective, they should be replaced. Tighten all items securely.

Caution: Exercise extreme care in handling the battery as any battery electrolyte spilled on the painted surface will cause damage to the finish. Further, clean any dirt or corrosion from top of the battery.

15. Check and service front suspensions

- (1) Check the front fork assembly by locking the front brake and pumping the fork up and down vigorously. In this case the motorcycle must not be on the main stand. If there is a slight knock felt in the steering

head balls, adjust the steering head top nut to remove excessive play. In this case care should be taken so that it will not be tighten excessively (Refer to page 118)

- (2) Change the oil in the front fork.
 - a. Unscrew the front fork drain plug at the bottom of the fork cylinder, drain the oil by pumping the forks while plug is out. Replace the plug securely after draining. (Fig. 19-16)
 - b. Remove the top filler plug and fill the front fork with 7.0~7.3 ozs. (220~230 cc) of premium quality of SAE 10 W-30 grade. (Fig. 19-17)
 - c. Securely tighten the top filler plug after filling.
- (3) Check the following items and if there is any fault, correct before riding.
 - a. Operation or attachment of the steering lock—repair or replace steering lock.
 - b. Tightness of the front fork mounting bolts (four on the bottom of the cylinders and two on the steering stem plate), steering stem top plate bolts and four handle bar holder bolts or front fork cylinder—tighten the loose bolts.

16. Check and service rear suspension

- (1) Lubricate grease nipples on the both side of the rear fork pivot shaft (Fig. 19-18) with multi-purpose grease type NLGI No. 2 every 6 months or every 3000 miles (5000 km), whichever occurs first.
- (2) Check the following items and if there is any fault, correct before riding.
 - a. Deform or cracks in welding spots in the rear fork—repair or replace.
 - b. Worn rear fork pivot bushing—replace bushing.
 - c. Tightness of rear cushion mounting bolts (upper and lower bolts)—retighten.

17. Check front and rear wheels and tires

- (1) Check the following items and if there is any fault, correct before riding.
 - a. Tightness of spokes—retighten loose spokes with even torque.
 - b. Deform of wheel rims—replace if run out exceeds the limit (refer to page 133).
 - c. Wear of wheel bearings—replace.
 - d. Bent of wheel axles—replace.
- (2) Check wear of tire tread and if the depth of tread becomes less than 0.08 in (2.0 mm) on the rear tire and 0.06 in (1.5 mm) on the front tire replace the tire.

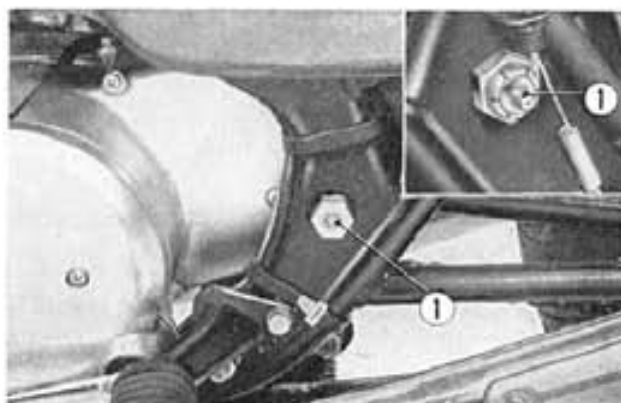


Fig. 19-18 ① Grease nipples

18. Check and service brakes

- (1) Check the wear of the front brake friction pads by measuring the clearance between the front of the caliper and brake disc face by means of a thickness gauge.

If the clearance becomes less than 0.08 in (2.0 mm) both friction pads should be replaced with new Honda genuine replacement pads as a set. (Fig. 19-19)

To replace the brake pads the brake caliper must be removed the front fork.

After replacing the brake friction pads remount the caliper to the front fork. (Refer to page 146)

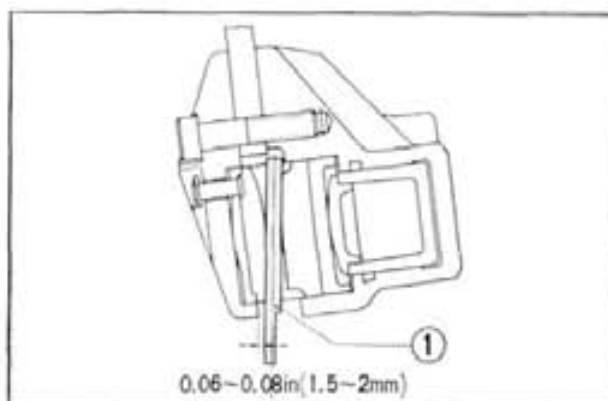


Fig. 19-19 ① Brake disc

- (2) The brake caliper must be adjusted so that there is a small clearance between the fixed friction pad and the brake disc. (Refer to page 147~148)
- (3) Check brake fluid seepage around the front brake system. If there is any symptom, repair it before riding.
- (4) Check the operation of the front brake and if the feeling of lever motion is soft or spongy, or lever travel is excessive, bleed the front brake system. (Refer to page 138~139)
For bleeding the brake or for replenishing the reservoir use only **SAE type 70R3** brake fluid.

Caution: Take care so that the paint surface will not be contaminated by the brake fluid, or otherwise the paint surface will be affected by the fluid.

- (5) Remove rear wheel and check the brake shoes for wear of linings. If the thickness of the lining becomes less than **0.08 in (2.00 mm)** at the most worn part, replace both brake shoes with new Honda genuine replacement brake shoes. Replace the rear wheel. (Refer to page 148~149)
- (6) Rear brake adjustment must be done by the rear brake adjusting nut to obtain the proper brake pedal free travel.

To adjust the rear brake free travel place the motorcycle on the main stand. Rotate the wheel by a hand and rate the distance of the pedal tip travel before the brake takes hold. Nominal free travel is approximately 1 in. (25 mm). Turn the adjusting nut clockwise for less free travel. After adjustment has been made make sure that the cut-out on the adjusting nut is seated on the brake arm pin.

Whenever the rear wheel is removed or the drive chain is adjusted check the brake pedal free travel.

- (7) Check the following components for crack or deformation and take proper steps as necessary.
 - a. Rear brake arm and brake cam.
 - b. Rear brake panel
 - c. Rear brake rod
 - d. Brake pedal
 - e. Rear brake torque link

19. Check and service drive chain and sprockets

- (1) Check and adjust slack of the drive chain according to the following procedure.
 - a. Place the motorcycle on the main stand. Move the chain up and down at midway point and check the total movement. It should be in 1/2 in to 1 in (10 mm to 25 mm).
 - b. When the adjustment is required remove the rear axle nut cotter pin and remove the rear axle nut. Loosen the two lock nuts on the drive chain adjusting bolts. Adjust the drive chain movement by equally rotating both adjusting bolts with the aid of scales marked on both sides of the rear fork.
 - c. Tighten the lock nuts of adjusting bolts and the axle nut to the specified torque of 58~72 ft. lb (8~10 kg-m). Install a new cotter pin and reinspect the slack of drive chain by rotating the rear wheel.
 - d. Drive chain should be checked and adjusted, at the specified intervals. If wear of the chain becomes excessive, replace it with a new chain of the same size.
- (2) Servicing grease to the drive chain is done according to the following steps.
 - a. To remove the drive chain, first remove the transmission sprocket cover screws and cover. Remove the forward chain cover bolt and loosen rear chain cover bolt. Position the drive chain master link or joint on the rear wheel sprocket and remove the retaining clip with pliers. Do not bend or twist the clip.

- b. Clean the chain thoroughly in a suitable solvent. Rinse in clean solvent and allow to dry. Inspect the chain for wear (joint sloppiness), stiffness and binding at the joints and broken or separated rollers. If any of these conditions exist, the chain should be replaced.
 - c. Immerse the chain in a pan or vessel containing a 10 to 1 ratio mixture of SAE 10W-40 engine oil and petroleum jelly (1/2 qt. oil to 5 oz. petroleum jelly) and heat to 150° to 250°F, (66~100°C) for approximately 10 minutes.
 - d. Remove the pan from the sources of heat and carefully agitate the immersed chain with a screw driver. When cool, remove the chain allowing it to hang over the pan and drain off excess lubricant. Use a cloth or rag to wipe off remaining excess lubricant.
 - e. Correctly route drive chain onto the sprockets using the rear sprocket to position the chain ends while installing the master link, link side plate and retaining clip. Note that the closed end of the retaining clip must face the direction of forward wheel rotation. (Fig. 19-20)
 - f. Adjust rear drive chain.
- (3) Check the drive and driven sprockets for wear in the teeth and replace the worn sprocket with a new one when it is badly worn.

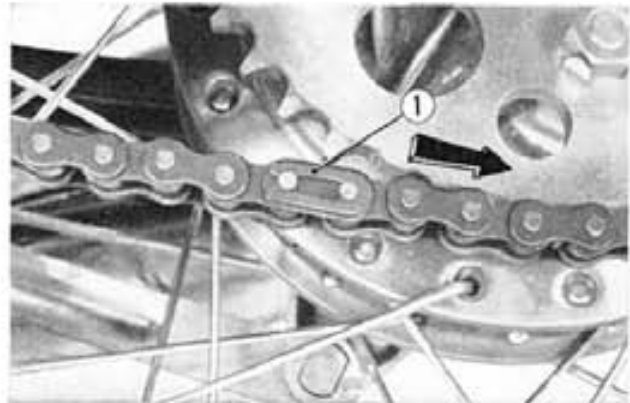


Fig. 19-20 ① Retaining clip

20. Check components of the body

- (1) Visibly inspect the frame for crack and deformation on the motorcycle which was reported as it was collided or split over before. If any of these conditions exist, replace the frame with a new one or repair it properly so that the wheel alignment will not be changed.
- (2) Check the exhaust pipe and muffler for gas leak and check oil tank and hose for oil seepage and correct fault as required.

21. Check and adjust lights, horn and instruments

- (1) Check focusing of head light beam and adjust it according to the following process when it is necessary.
 - a. The vertical adjustment is made by loosening the bolts which mount the headlight assembly. The headlight is adjusted in the vertical direction so that the center of the beam inspects the ground at the point 164 feet (50 m) in front of the motorcycle with the motorcycle in the riding attitude.
 - b. The horizontal beam adjustment is made with the adjusting screw located on the left side of the headlight when facing the motorcycle. Turning the screw in will focus the beam toward the left side of the rider and turning the screw out will focus the beam toward the right side. Adjust



Fig. 19 21 ① Headlight mounting bolts
② Adjusting screw

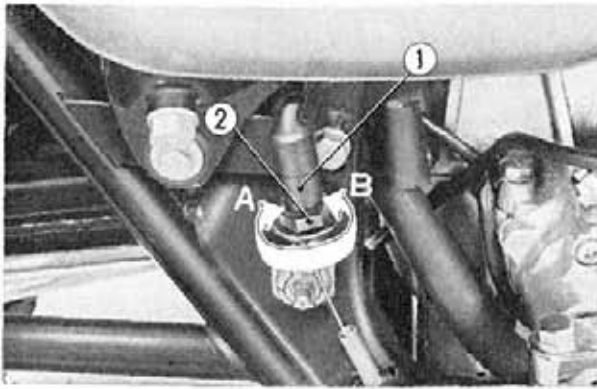


Fig. 19-22 ① Stop light switch
② Lock nut

- the beam to coincide with the center line of the motorcycle. (Fig. 19-21)
- (2) Check operation of stop light switches on the front brake master cylinder and at the rear brake pedal separately. The one on the front brake is not adjustable and the other on the rear brake is adjustable. Therefore when the front brake switch become out of order it has to be replaced.

Adjust the rear brake stop light switch so that the stop light will come on when the brake pedal is depressed to the point where the brake just starts to take hold. If the stop

light switch is late in switching on the stop light, screw in Ⓐ the switch lock nut and if the stop light comes on too early, screw out Ⓑ the switch lock nut. (Fig. 19-22)

- (3) Check operation of turn signal lights and repair when it is necessary.
- (4) Check horn, speedometer and tachometer for function and replace them when it is necessary

COMPARISON OF CB750K1 to CB750

ENGINE MECHANICAL

LUBRICATION SYSTEM

DRIVE CHAIN OILER

The oil which lubricates the chain is fed from the center of the shaft, through the porous sintered oil reserve element ⑦, along the outer surface of the rubber orifice ⑤, out the oil passage ④ and along the surface of the drive sprocket.

To simplify the procedure for regulating the feed of the lubricant, it is performed by the adjusting screw ① in the chain oiler. Turning the screw clockwise (A direction) will force the rubber orifice against the oil reserve element, causing it to expand and restricting the flow of oil around the rubber orifice. Turning the adjusting screw counter clockwise (B direction) will permit the rubber orifice to shrink toward its normal size and allow greater oil flow. In other words, the change in the diameter of the rubber orifice regulates the amount of oil to lubricate the drive chain.

ADJUSTMENT PROCEDURE

1. Remove the rear crankcase.
2. Wipe the oil on the drive chain thoroughly with a rag.
3. The adjusting screw is adjusted to maximum oil flow on all motorcycles leaving the factory. After riding for a short period, if excessive oil is noticed by indication of chain oil on the rim, fender, spokes etc., turn the adjusting screw about 1/4 turn in the clockwise direction and recheck the oil flow condition after riding for one minute at 50~70 mph (80~110 kph). The adjustment is proper if the chain link plates and rollers are

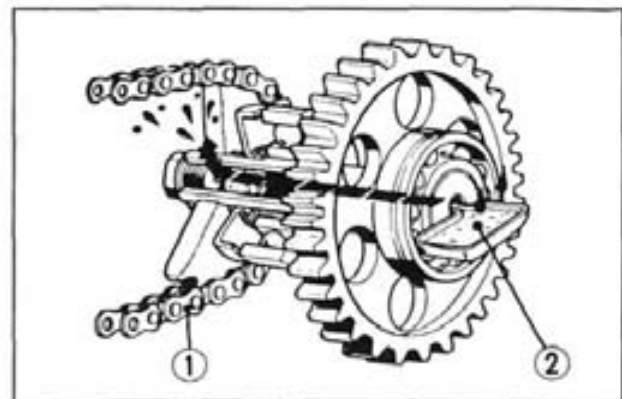


Fig. 20-1 ① Drive chain
② Oil guide

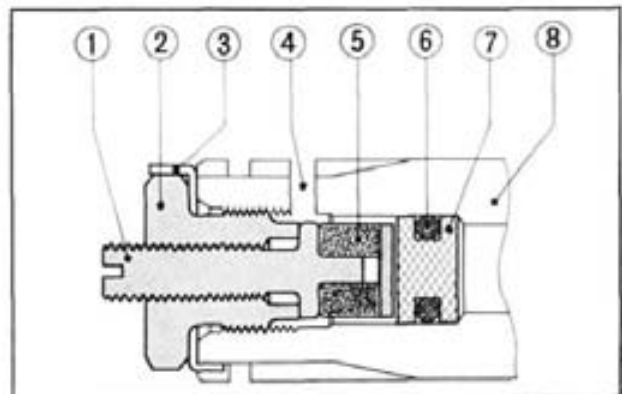


Fig. 20-2 ① Adjusting screw
② Final shaft plug
③ 14 mm lock washer
④ Oil passage
⑤ Rubber orifice
⑥ 6.5×3 O-Ring
⑦ Oil reserve element
⑧ Final driven shaft

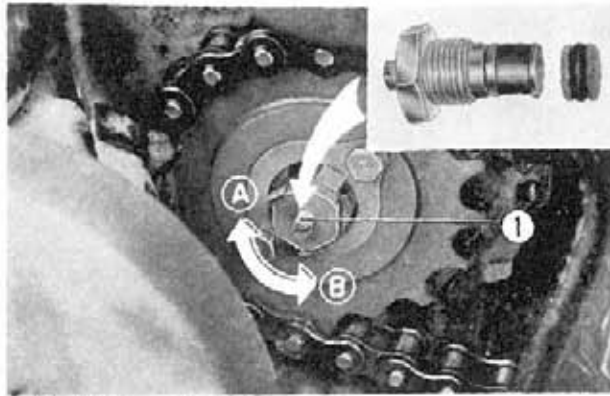


Fig. 20-3 ① Adjusting screw

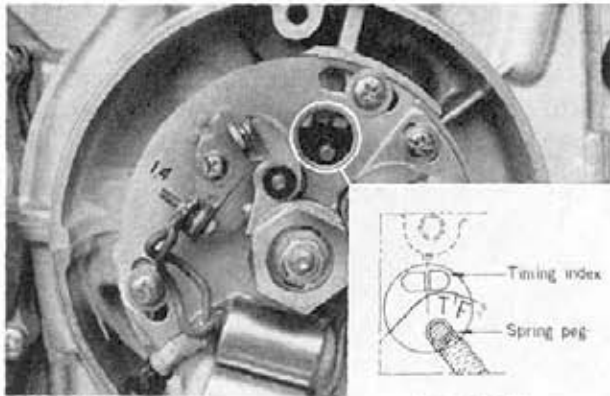


Fig. 20-4 Point cam position at 15° ATDC

2. Remove the point cover, and use a 23 mm box wrench to rotate the crankshaft to the "T" position for cylinders #1 and #4 (1.4).
3. Check the both valves of #1 cylinder. If both valves are free, proceed to next step; if either or both of the valves are tight, rotate the crankshaft 360°, and then proceed with the next step.
4. Rotate the crankshaft clockwise until the spring peg on the advancer assembly at the 1.4 position is just to the right of a line from the timing index. (Fig. 9) This position is 15° ATDC 1.4.

At this point, the slack in the cam chain will be on the tensioner side, thus assuring effective tensioner operation.

5. Loosen the cam chain tensioner lock nut, and back out the setting screw until the tensioner arm is released and moves in to take up the slack.

Note: The tensioner is automatic. Do not use additional pressure to remove the tensioner arm.

6. Retighten the setting screw and lock nut, re-install point cover and tappet covers.

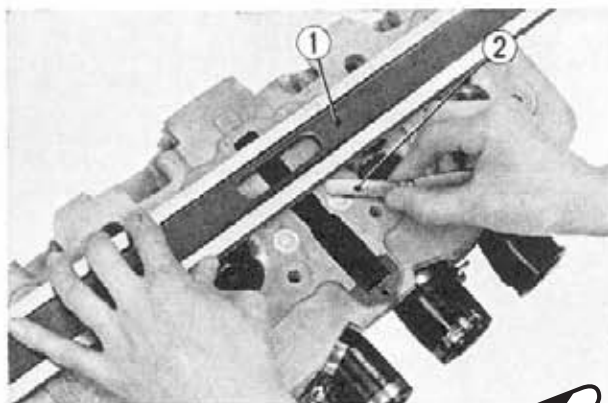


Fig. 20-5 ① Stretch
② Thickness gauge

wet with oil and the other areas are free from excessive oil.

4. Readjust the screw if necessary until the proper oiling condition is obtained.

SUPPLEMENT LUBRICATION

Drive chain rollers and side plates must be properly lubricated at all times. Sustained high-speed driving or improper adjustment of the chain oiler may cause inadequate lubrication. If the rollers or side plates are dry or show evidence of rust, apply a high-quality chain lubricant according to the manufacturer's instructions.

CAM CHAIN TENSIONER

A loose cam chain causes a loud clattering noise. It may also affect valve timing, resulting in performance loss.

A recommended crankshaft position for adjusting the cam chain tensioner is that when the crankshaft is rotated to 15° ATDC of cylinders #1 and #4, immediately after cylinder #1 has fired.

Adjustment

1. Remove the tappet covers from the #1 cylinder.

CYLINDER HEAD

When measuring the flatness of the cylinder head, place a straight across the measuring surface of the cylinder head.

Check the clearance with a thickness gauge at several points and make sure the head not to be warped.

| Item | Standard value | Serviceable limit |
|-----------|-----------------------------|-----------------------------|
| Clearance | 0.002 in. (0.05 mm max.) | 0.009 in. (0.25 mm max.) |

Rework the cylinder head or replace with new one if beyond the serviceable limit.

FUEL SYSTEM

CARBURETOR (link type)

The quadruple piston type carburetors are mounted on the cylinder head with a stay plate. Choke lever is a link type which operates all four choke valves simultaneously.

To simplify the idle adjustment and synchro-

nization of the carburetors, the throttle cables from the four carburetors are joined to operate from a single linkage.

Fig. 11 shows the construction details of the carburetor.

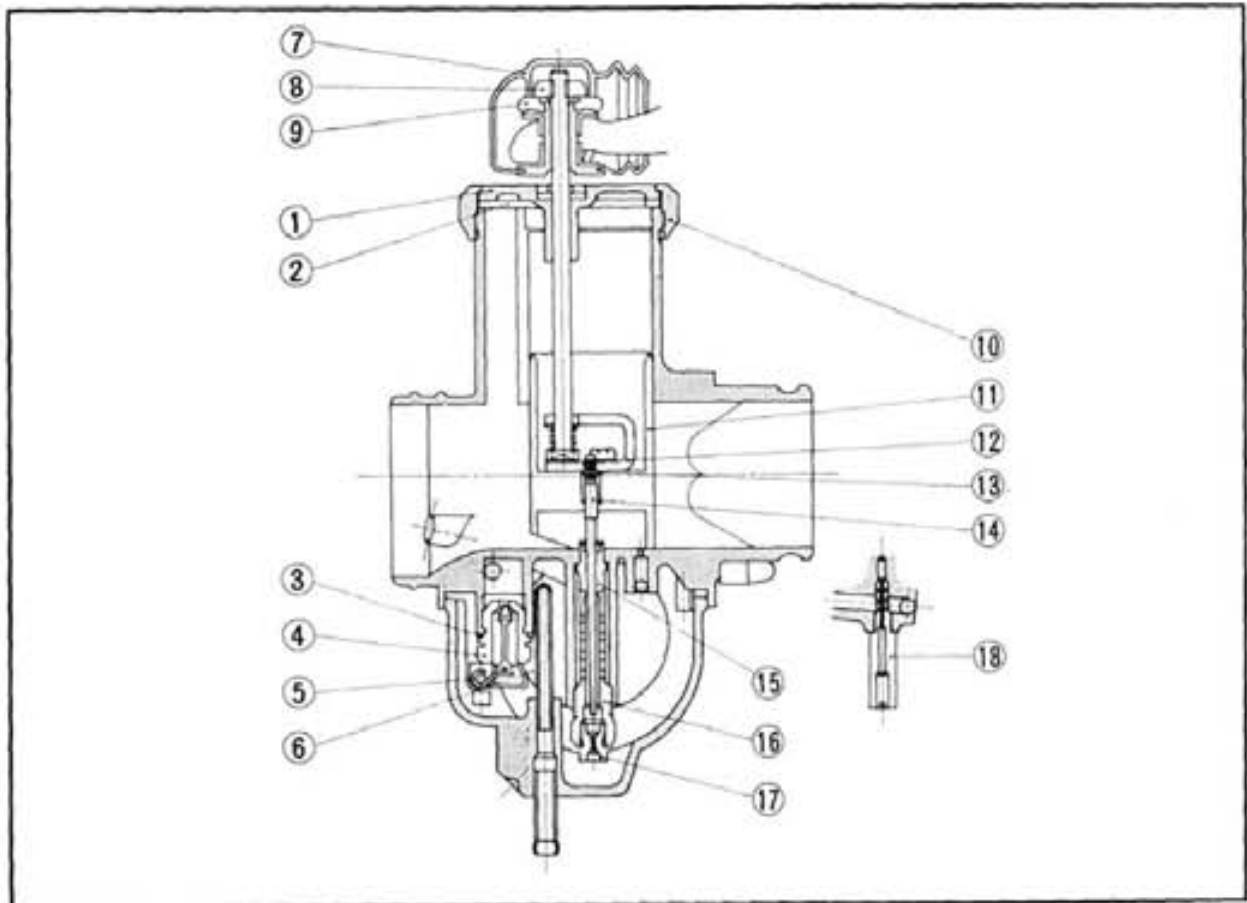


Fig. 20-6

- | | |
|------------------|---------------------|
| ① Carburetor top | ⑩ Cap |
| ② Top washer | ⑪ Throttle valve |
| ③ Flat washer | ⑫ Needle set plate |
| ④ Valve seat | ⑬ Clip |
| ⑤ Float arm pin | ⑭ Jet needle |
| ⑥ Float | ⑮ Needle jet |
| ⑦ Rubber cap | ⑯ Needle jet holder |
| ⑧ Lock nut | ⑰ Main jet |
| ⑨ Adjuster screw | ⑱ Slow jet |

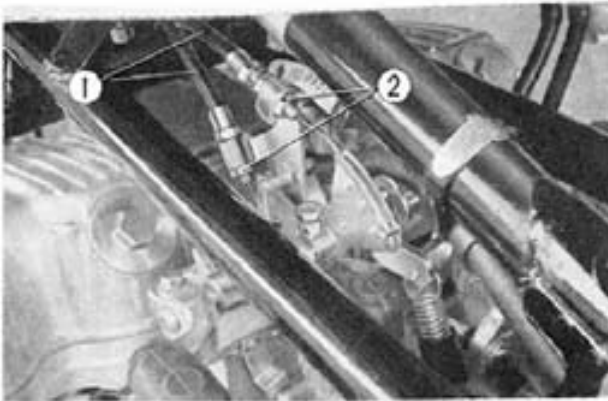


Fig. 20-7 ① Throttle cable
② Lock nuts

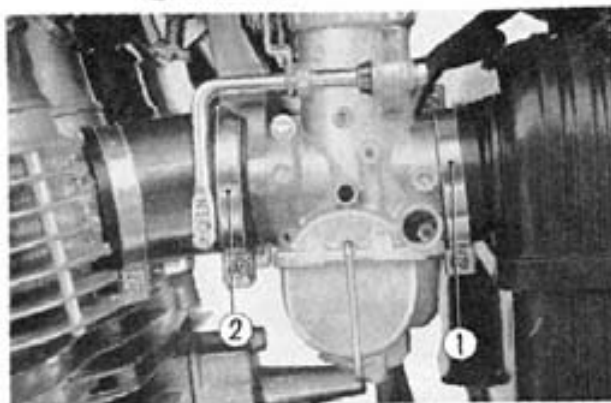


Fig. 20-8 ① Air cleaner connecting band
② Carburetor insulator band

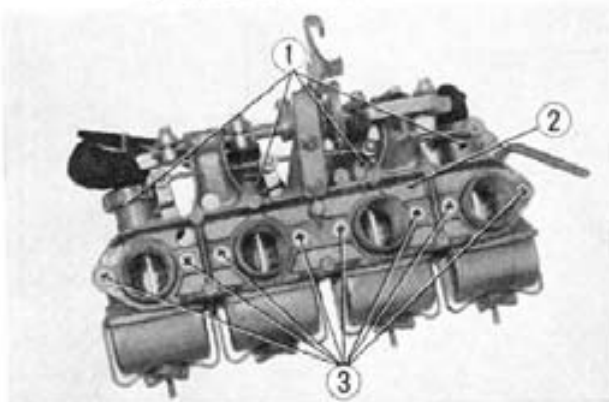


Fig. 20-9 ① Carburetor ② Carburetor stay plate
③ Setting screws

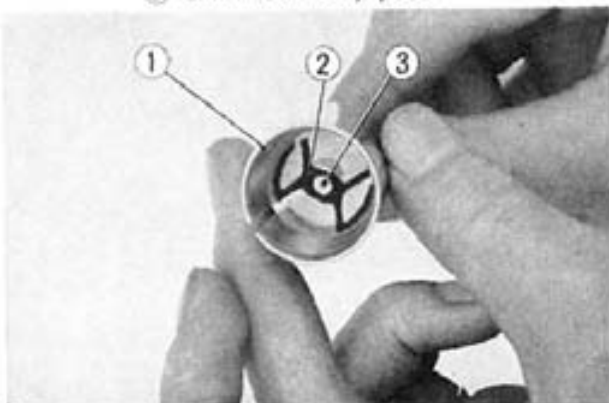


Fig. 20-10 ① Throttle valve ② Needle set plate
③ Jet needle

DISASSEMBLY

1. Turn the fuel tank valve to the "STOP" position, remove the fuel lines from the fuel valve body, raise the seat and pull the rear tank rubber mounting away from the rear tank mount. Remove the fuel tank.
2. Disconnect the throttle cables from the link lever, loosen the air cleaner connecting tube and insulator bands and then remove the carburetors as an assembly.
3. Unscrew two 6 mm screws and dismount the respective carburetor from the stay plate. Disconnect the individual choke rod and separate the carburetors.
4. In order to remove the needle jet from the throttle valve, remove the needle set plate.

5. Remove the float chamber retightening clip and remove the following carburetor components with a small screwdriver.

- * Slow jet
- * Main jet
- * Needle jet holder
- * Float
- * Float valve set

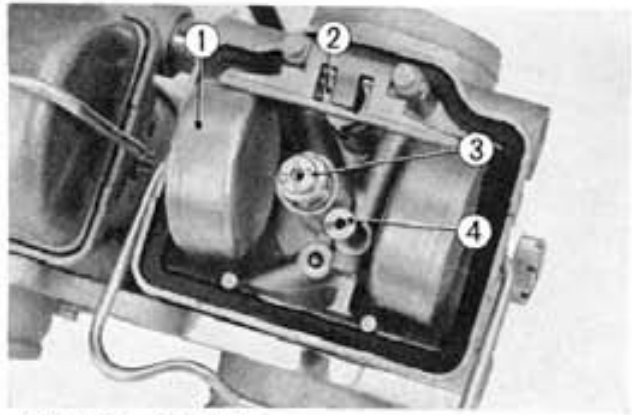


Fig. 20-11 ① Float
② Float valve set
③ Main jet
④ Slow jet

INSPECTION

1. Carburetor adjustment should be made in accordance with the description on page 186.

2. Fuel level check

Remove the float chamber and set the float arm as shown in the Fig. 20-12 so that it just barely touches the valve and in this position, check the position of the float with the gauge set vertically. At a standard setting, the float should just barely come in contact with the gauge. If there is clearance between the gauge and float or if the float is interfering with the gauge, adjustment should be made. The height of float above the carburetor body, which should be **1.023 in. (26 mm)** can be adjusted by bending the float arm using a narrow screwdriver.

3. Jet needle, float valve

The jet needle is constantly moving and if it is found to be excessively worn, it should be replaced. Further, check the wear of the valve and the valve seat and if it is defective, part should be replaced. (Fig. 20-13)

4. The clogging of the respective jet should be cleaned by blowing out the jets with compressed air followed by properly torquing the jets.

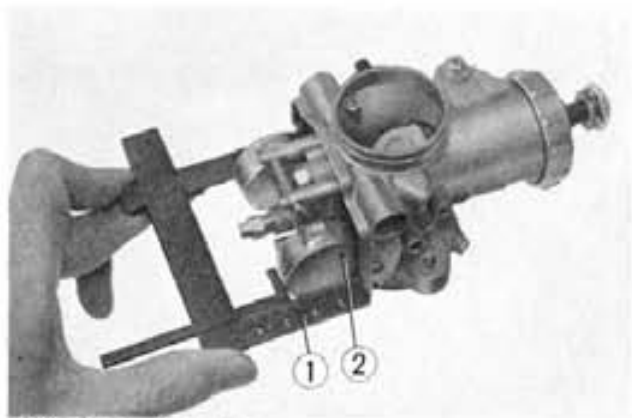


Fig. 20-12 ① Float
② Float level gauge

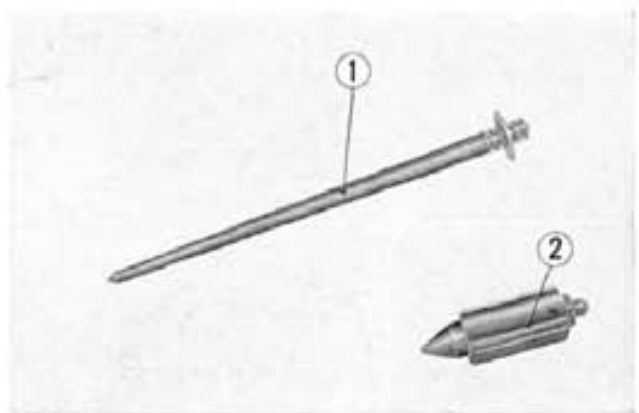


Fig. 20-13 ① Jet needle
② Float valve

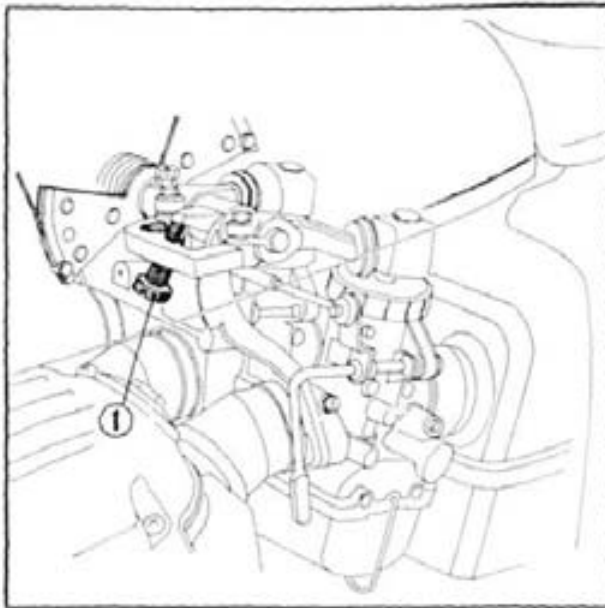


Fig. 20-14 Idle adjustment
① Throttle stop screw

ADJUSTMENT

Adjustment is normally performed after the engine has been warmed up to operating oil temperature of 140° to 157°F (60 to 70°C).

Idle adjustment

Set the engine idle speed to 900–1,000 rpm with the throttle stop screw. (Fig. 20-14)

- * Turning the stop screw in the clockwise direction will decrease the idle speed.
- * Turning in the counter clockwise direction will increase the idle speed.

Carburetor synchronization

1. Remove the fuel tank from the frame and position it approximately 20 in. (50 cm) higher than motorcycle, and then reconnect the tank and the carburetor system with a rubber tube.
2. Remove the rubber boot from the link arm.
3. Connect up the vacuum gauges. Remove the carburetor plugs and connect the longer size adapters to the two inside carburetors, and the shorter size adapters to the outside carburetors.

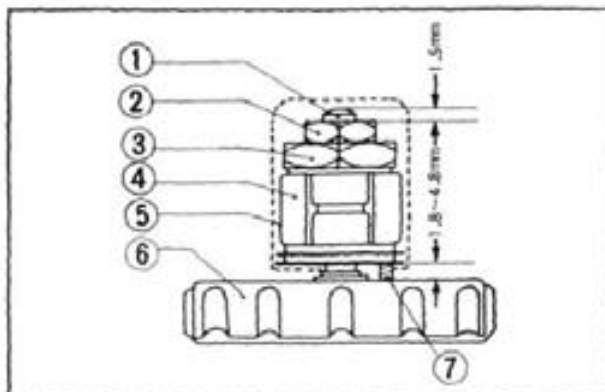


Fig. 20-15 Link component

| | |
|------------------|---------------|
| ① Rod | ⑤ Rubber boot |
| ② Lock nut | ⑥ Top |
| ③ Adjuster screw | ⑦ Gauge |
| ④ Link arm | |

4. Start the engine, loosen the adjuster screw lock nut and turn the adjuster screws so that the vacuum gauges connected to the carburetors are all indicating uniformly (within 3.0 cmHg) between 16 to 24 cmHg. (Fig. 20-15)

- Turning the adjuster screw in the clockwise direction will raise the vacuum pressure.
- Turning the screw in the counter clockwise direction will lower the vacuum pressure.

Note:

Before synchronizing the carburetor with the vacuum gauge, make sure that all the rods are extending at least one thread above the lock nut. (Fig. 20-16)

If there is insufficient thread extension, the following preadjustment must be made before adjusting the synchronization.

- ① Turn the throttle stop screw until there is a slight clearance between the stopper and the screw.
 - ② Adjust the adjuster screw so that there is a **0.070-0.189 in. (1.8-4.8 mm)** clearance between the adjuster screw and the top. (Fig. 20-15)
 - ③ Turn the throttle stop screw in the counter clockwise direction back to the original position.
5. When all the carburetors are indicating uniform vacuum pressure, adjust the throttle stop screw to obtain the specified idle speed.
6. Snap the throttle several times to verify the idle stability before tightening the lock nut.
- Torque lock nut to: **0.86-1.44 ft-lbs (12-20kg-cm)**

Carburetor air screw adjustment

Adjust the respective air screw so that the engine rpm is smoothest with maximum vacuum pressure. The standard adjustment which gives best performance is $3/4$ to $1/4$ turns open from the full close position.

Note:

After the adjustment is completed, make sure that the rubber boots is not pinched or rolled under.

Overcross stop adjustment

Loosen the lock nut and turn the eccentric link pin to provide a clearance of **0.08-0.12 in. (2-3 mm)** between the throttle lever and link pin. (Fig. 20-17, 20-18)

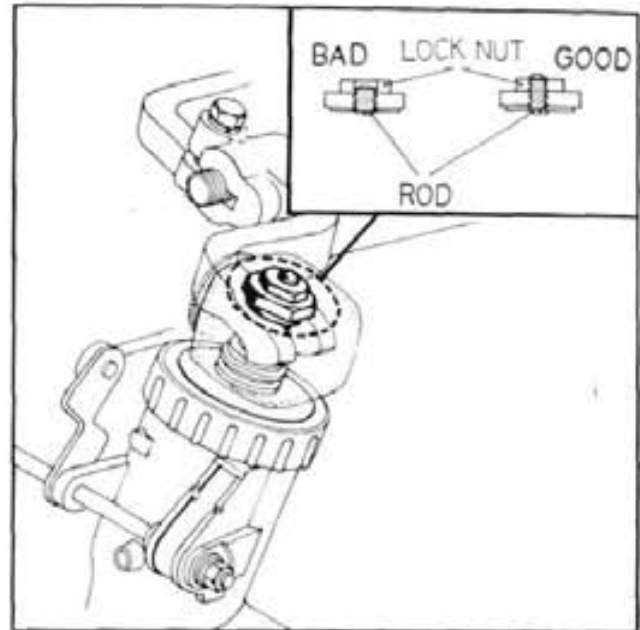


Fig. 20-16 Lock nut

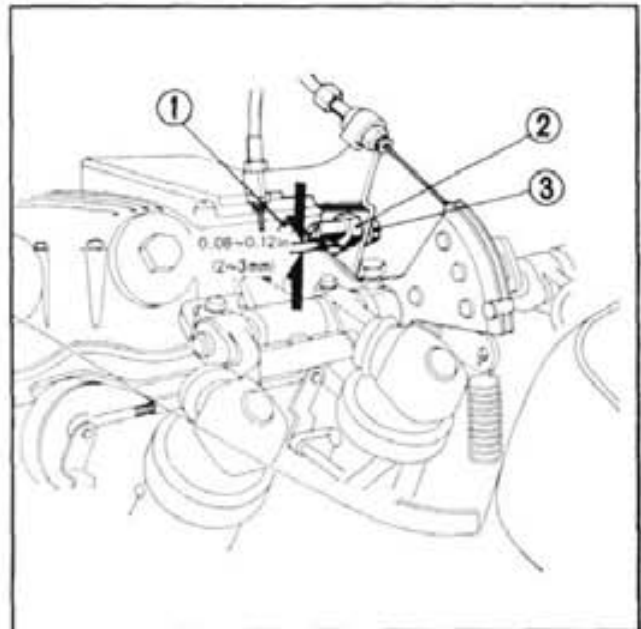


Fig. 20-17 Overcross stop adjustment

- ① Throttle lever ③ Lock nut
② Eccentric link pin

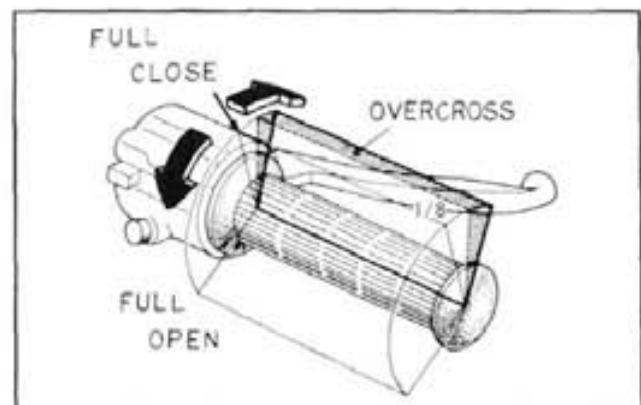


Fig. 20-18 Overcross part

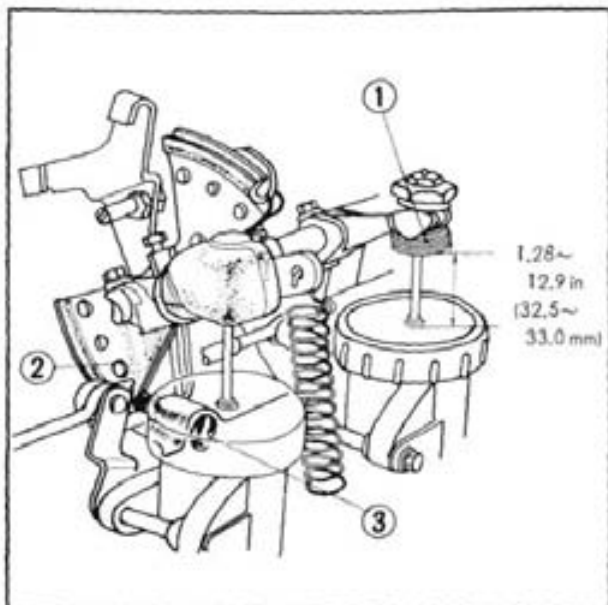


Fig. 20-19 Full open stopper adjustment

- ① Adjuster screw
- ② Throttle lever
- ③ Full open stopper screw



Fig. 20-20 Throttle cable adjustment

- ① Adjust nut
- ② Lock nut

Full open stopper adjustment

Adjust the stopper screw so that there will be a distance of **1.28–1.29 in. (32.5–33.0 mm)** between the top and the adjuster screw with the throttle grip in the full open position. (Fig. 20-19)

Throttle cable adjustment

1. Turn the adjuster counter clockwise on the handle end to increase the play in the cable. To permit fine adjustment with the adjuster screw, leave about a **0.12 in. (3 mm)** play in the cable.
2. Turn the adjuster nut at the carburetor end to provide a **0.12–0.16 in. (3–4 mm)** play at the grip flange. (Fig. 20-20)

Note:

The throttle lever should hit the link pin when the grip is forced to the full close position.

If this does not occur, the throttle cable must be replaced.

STEERING AND FRONT SUSPENSION

FRONT SUSPENSION

The front fork is assembled into a complete unit by the fork bottom bridge, axle and the fork top bridge and their respective mounting bolts. This three-point mounting

design provides a highly rigid unit for good stability. The front suspension is a telescoping oil damper type with an aluminum fork bottom case used for lightness.

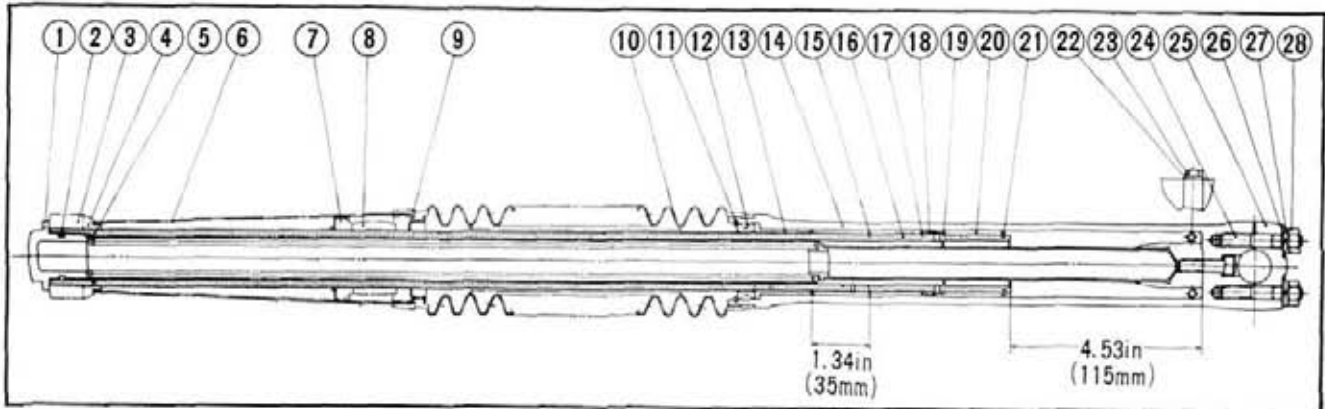


Fig. 20-21

- | | | |
|----------------------------|---------------------------|-------------------------|
| ① Front fork bolt | ⑪ 50 mm circlip | ⑳ Fork piston snap ring |
| ② 23×28 "O" ring | ⑫ 354811 oil seal | ㉑ Drain cock packing |
| ③ Fork top bridge | ⑬ Front fork pipe guide | ㉒ 6 mm hex bolt |
| ④ Fork cover upper cushion | ⑭ Front fork bottom case | ㉓ 8 mm stud bolt |
| ⑤ Front cushion spring | ⑮ Fork pipe stopper ring | ㉔ Front axle holder |
| ⑥ Front fork cover | ⑯ Front fork pipe | ㉕ 8 mm flat washer |
| ⑦ Fork cover lower cushion | ⑰ Fork valve stopper ring | ㉖ 8 mm spring washer |
| ⑧ Steering stem | ⑱ Front damper valve | ㉗ 8 mm hex nut |
| ⑨ Front fork rib | ㉘ Piston stopper ring | |
| ⑩ Front fork boot | ㉙ Front fork piston | |

As the outside diameter of oil seal 354811 is 0.08 in. (2 mm) larger than previous model to prevent the deformation of oil seal and oil leakage, the diameter (50 mm) of circlip is also larger than previous one (47 mm).

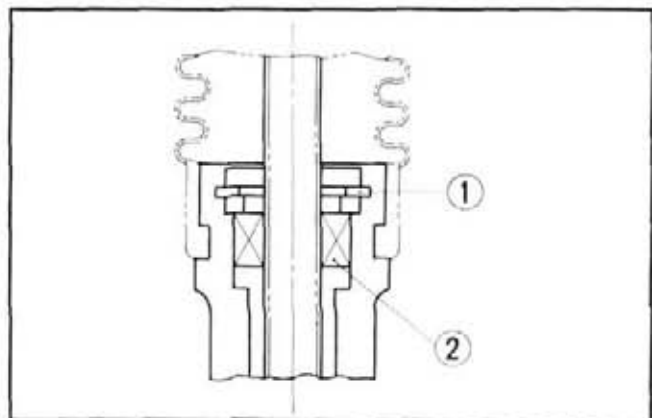


Fig. 20-22 ① 50 mm circlip
② 354811 oil seal

REAR SUSPENSION

REAR SHOCK ABSORBER

A De Carbon type damper containing nitrogen gas under high pressure is contained within the cylinder to maintain a pressure against the oil. This prevents the bubbles from being produced in the oil during compression. It assures positive

damping action. The spring force can be adjusted to the three positions according to carrying load and riding condition. The stroke of the rear shock absorber is 3.4 in. (87 mm).

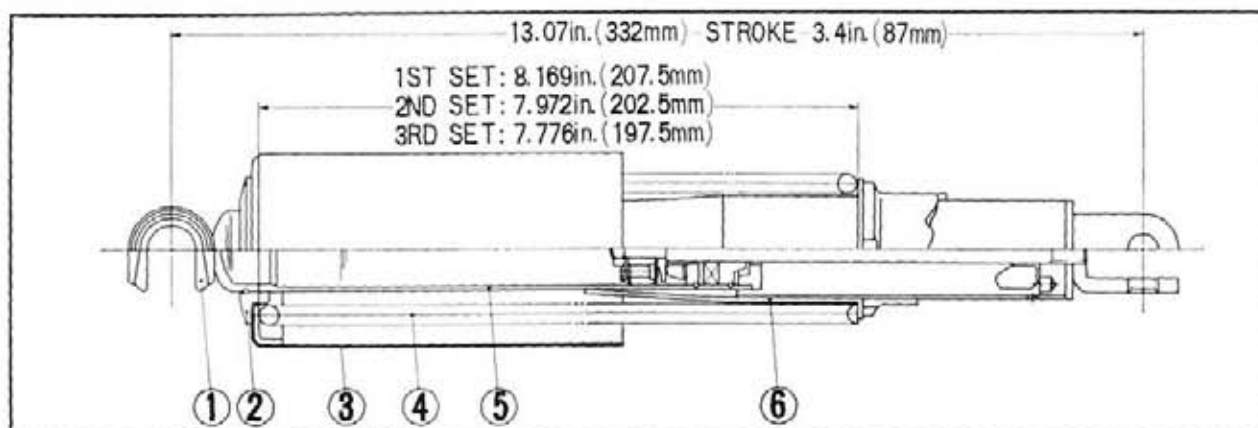


Fig. 20-23 ① Joint rubber ④ Rear cushion spring
 ② Spring seat stopper ⑤ Rear damper assembly
 ③ Rear cushion upper cover ⑥ Rear cushion spring guide

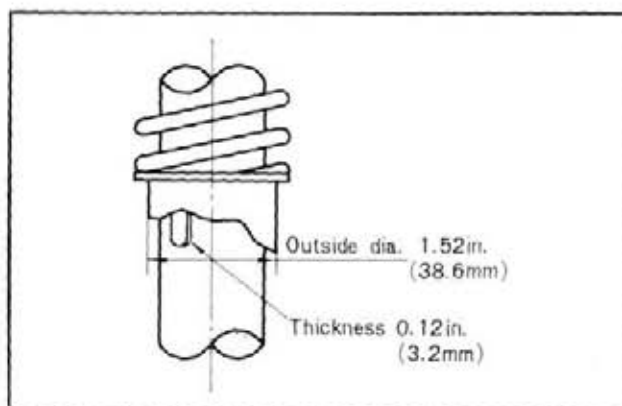


Fig. 20-24

The stopper was changed 0.09 in. (2.3 mm) to 0.12 in. (3.2 mm) thickness and the outside diameter 1.52 in. (38.6 mm) of shock absorber is 0.08 in. (2 mm) larger than previous one. Consequently, the spring diameter is 0.15 in. (4 mm) larger than previous model. The modifications described above provide a highly rigid.

Inspection

Damping force cannot be measured, therefore, the test is performed by compressing the shock absorber unit by hand. Normal operating condition is indicated by a greater resistance on the extension stroke than on the compression stroke.

When replacing the shock absorber spring, make sure that the new and previous spring are not interchangeable.

| Item | Standard value | Serviceable limit |
|-----------------------|------------------------------------|--------------------|
| Shock absorber spring | | |
| Spring inner diameter | 1.56~1.86 in. (39.7~40.3 mm) | — |
| Free length | 8.58 in. 218 mm | 8.346 in. (212 mm) |
| Coil diameter | (0.276 in. 7 mm) | — |
| Installation load | 7.98 in./66.6 lbs (202.9mm/30.2kg) | — |
| Tilt | within 1.5° | Over 2.5° |

WHEELS, TIRES AND FINAL DRIVE

FRONT WHEEL HUB AND MOUNTING BOLTS

As the width of the front wheel hub was made 0.157 in. (4 mm) narrow in width, the length of the mounting bolts was changed from 4.17 to 4.02 in. (106 to 102 mm) shortened by 0.157 in. (4 mm).

Whenever replacing these parts, make sure that the proper length bolts are used. Using the old longer bolts on the new hub will cause the disc plate to loosen during riding. When the front hub is replaced, the associated parts corresponding to this hub must be replaced in set. Old and new parts are not interchangeable.

REAR WHEEL DAMPER

The shape of both side wheel dampers which was changed as shown in figure, absorb the shock when the rear wheel was turned by the drive chain and it makes the the drive chain to prolong the service life.

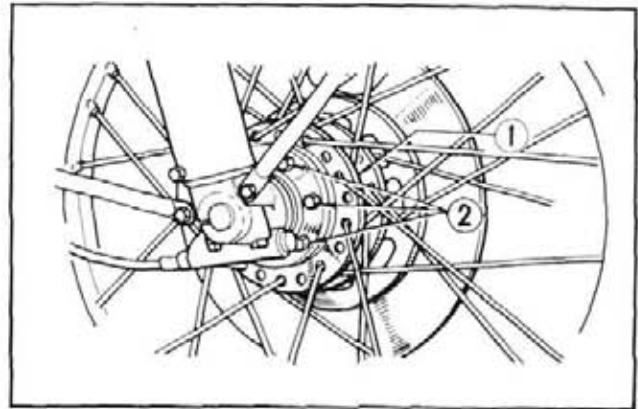


Fig. 20-25 ① Front wheel hub
② Disc plate mounting bolts

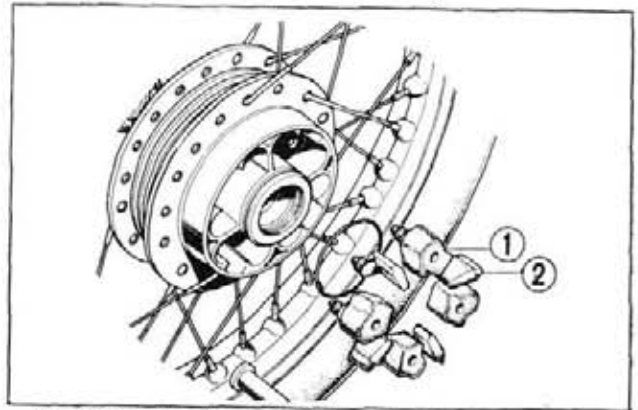


Fig. 20-26 ① R. rear wheel damper
② L. rear wheel damper

BODY, OIL TANK, AIR CLEANER AND EXHAUST SYSTEM

OIL TANK AND OIL COVER

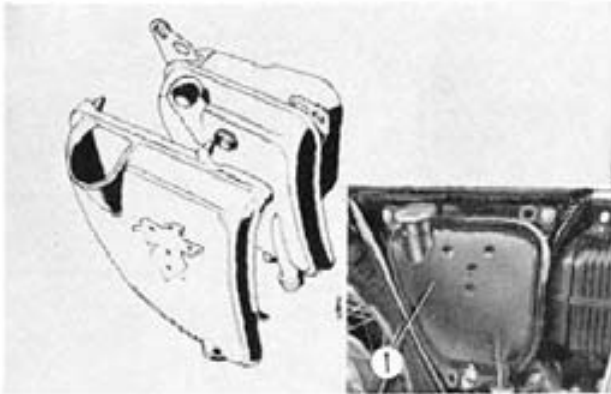


Fig. 20-27 ① Oil tank

The oil tank mounted on the right side center of the motorcycle is connected to the engine with two oil hoses. Since the oil tank was made narrow in width, the oil tank cover was designed sporty shape and narrow in width.

Note:
Both new and old are not interchangeable.

AIR CLEANER COVER, SEPARATOR CASE AND CLEANER CASE

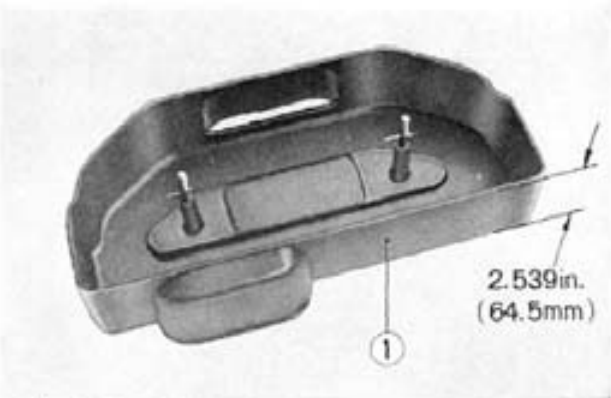


Fig. 20-28 ① Air cleaner cover

The air cleaner mounted at the center of the motorcycle under the fuel tank which was made narrow in width and the material was improved against chemical reaction and vibration shock when travelling on rough roads. The air cleaner cover was designed 0.08 in. (2 mm) narrow in width with concave parts on both side of it. The height of knobs on separator case was made 0.13 in. (3.5 mm) higher and the air cleaner case was designed as shown in Fig. 20-29.

Note:
If the air cleaner cover, separator case, cleaner cover and battery cover are replaced in set, new and old are interchangeable.

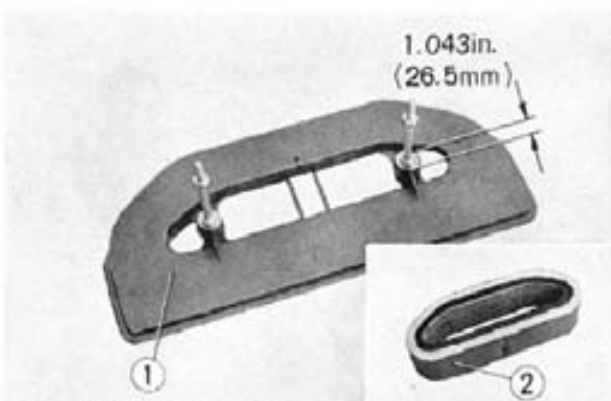


Fig. 20-29 ① Air cleaner separator case
② Air cleaner element

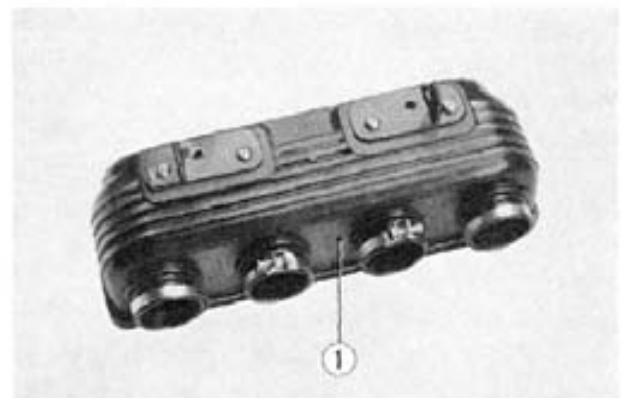


Fig. 20-30 ① Air cleaner case

BATTERY COVER

The battery cover was narrowed in width and its shape was designed sporty looking with alluring emblems. Therefore, there are not interchangeability.

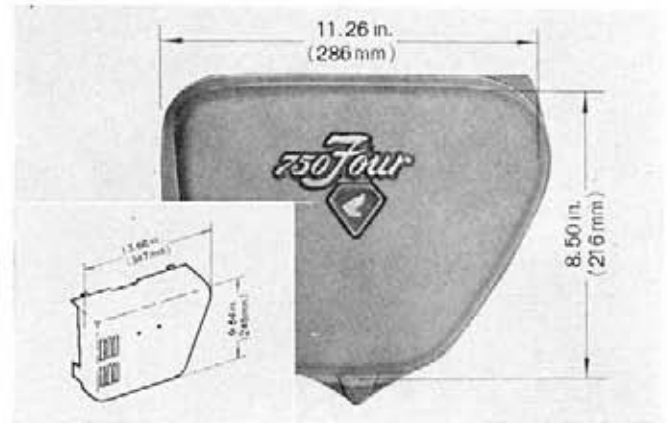


Fig. 20-31

SEAT AND SEAT LATCH

The front part of the seat was made narrow and the seat was designed into the double seat type covered with vinyl leather.

A seat latch of flip motion type was equipped to simply lock or unlock the seat.

Note:

If the seat latch, hook and seat are replaced at the same time, new and old are interchangeable.

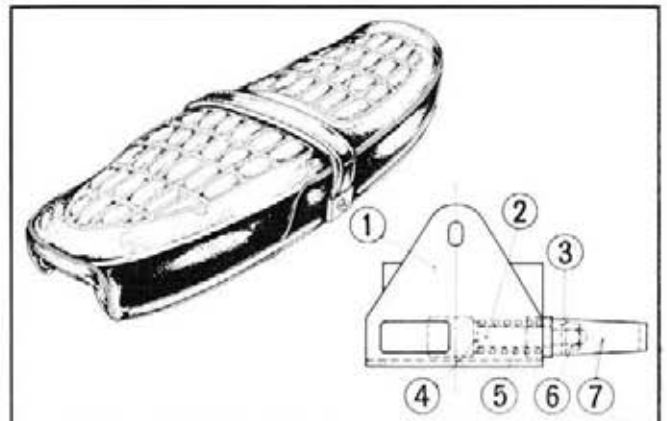


Fig. 20-32 ① Seat catch plate
② Seat catch slider
③ 6 mm, washer
④ 8 mm, washer
⑤ Seat catch spring
⑥ 6 mm nut
⑦ Seat catch lever

MAIN STAND

The welded metal sheet shown in Fig. 51 was made 0.4 in. (10 mm) wider for providing the stability when the main stand was operated.

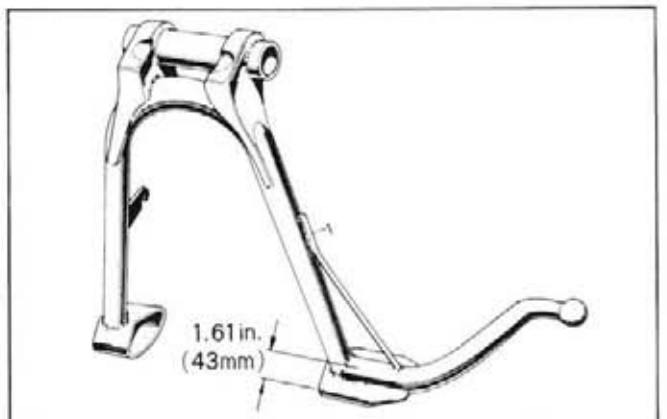


Fig. 20-33

BODY ELECTRICAL AND INSTRUMENTS

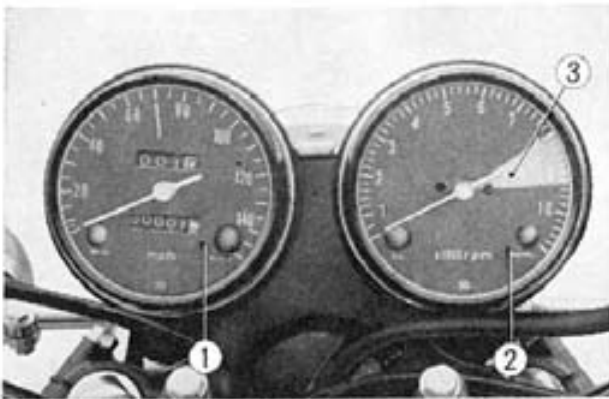


Fig. 20-34 ① Speedometer
② Tachometer
③ Red zone

SPEEDO/TACHOMETER

The speedometer and tachometer cases were painted flat black to prevent annoying reflection. Further, to provide the superior quality against the brake fluid reaction, the material of both windows was changed to the glass from the acrylic resin, and the tachometer red zone is 8,000~9,500 rpm.

DRIVE CHAIN CONNECTOR AND DISCONNECTOR OPERATION

On the models CB 750, it is necessary to cut the endless chains. To cut the chains, proceed as follows:

A. Disconnection of Drive Chain

1. Position chain link pin to be cut on chain holder in place as shown in Fig. 20-35. Screw in pressure bolt until pressure holder holds chain in position. Back off adjuster bolt so that it does not interfere with chain.
2. By use of handlebar, screw in pressure bolt B until before joint pin is just pushed off joint plate.
3. Position adjacent chain link pin on chain holder and repeat step 1 and 2. screw in pressure bolt B until joint pin is completely pushed off joint plate.
4. Reposition original chain link pin on chain holder and disconnect chain by pushing off joint pin in the same way as in step 3.

B. Press-in Connection of Drive Chain

Newly improved chain joints and plates are of a pressfitted type. Only press-fitted type chain joint and plate require this procedure.

1. Join new drive chain by inserting joint pin from side toward enter of motorcycle.

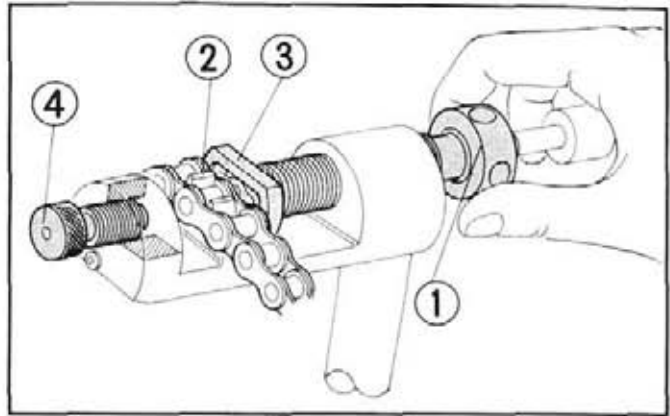


Fig. 20-35 ① Pressure bolt ③ Pressure holder
② Chain holder ④ Adjuster bolt

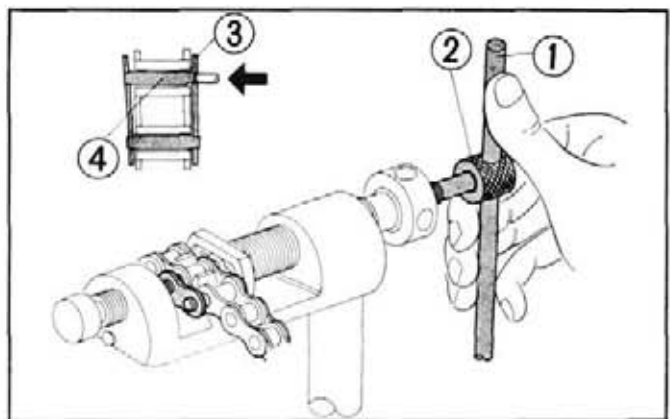


Fig. 20-36 ① Handlebar ③ Joint plate
② Pressure bolt B ④ Joint pin

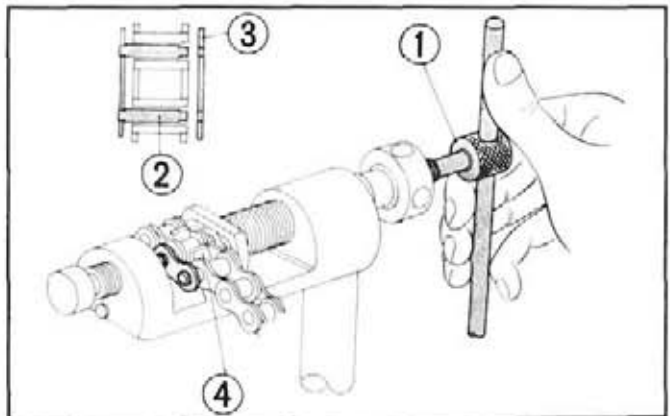


Fig. 20-37 ① Pressure bolt B ③ Joint plate
② Joint pin ④ Chain holder

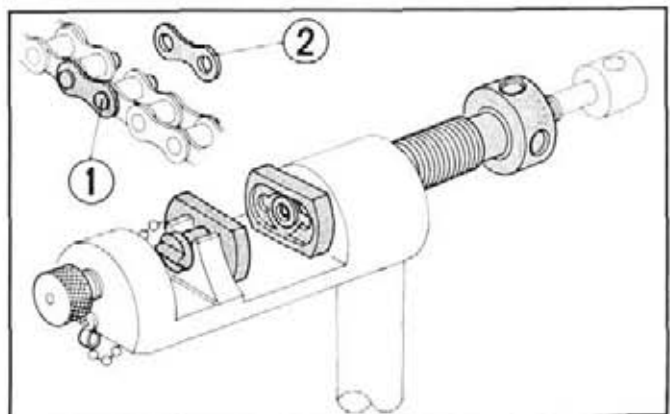


Fig. 20-38 ① Joint pin
② Joint plate

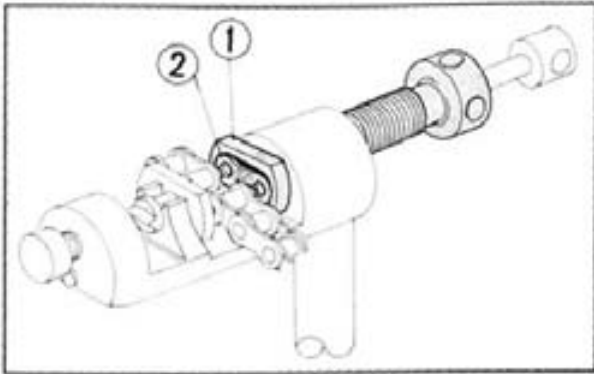


Fig. 20-39 ① Pressure holder
② Joint plate

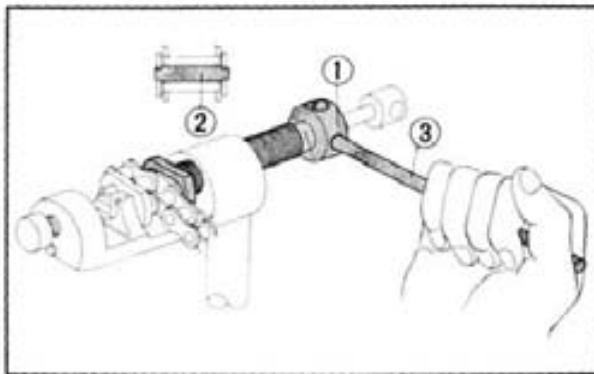


Fig. 20-40 ① Pressure bolt A
② Joint pin ③ Handle bar

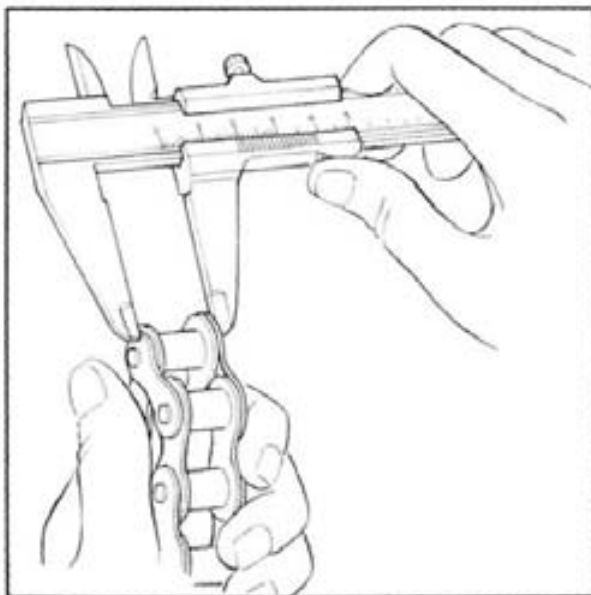


Fig. 20-41

2. Apply a thin coat of grease in recess of pressure holder. Set joint plate in recess of pressure holder with chamfered side (side with chain code stamped on it) inward, exercising care not to drop it.

3. Position chain portion to be connected between chain holder and pressure holder. Hold chain in position by screwing in pressure bolt A. After making sure that two pins of joint pin align with corresponding two holes in joint plate. By turning in pressure bolt A with handlebar, press-fit until it goes no longer because of steps on pins.

4. Measure distance between two joint plates to make sure if correctly press-fitted.

Specified distance between two plates:

DID50HDS.....19.7mm

DID50DS19.0mm

If reading exceeds specifications as above, repeat steps.

C. Staking of Drive Chain

1. Position drive chain joint portion to be staked on chain holder in place and also place wedge holder between chain holder and pressure holder as shown in Fig. 20-42. So that tip of wedge is in line with center of joint pin.
By tightening finger-tight, move forward pressure bolt A until it stops.

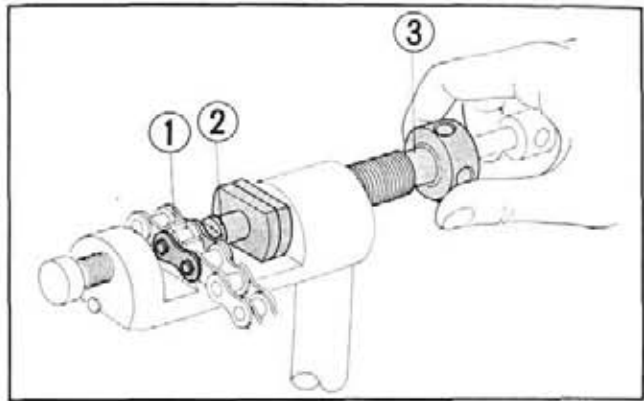


Fig. 20-42 ① Chain holder
② Joint pin
③ Pressure bolt A

2. Screw in adjuster bolt until opposite end of joint pin is forced against it.

NOTE:

Screw in adjuster bolt until finger-tight.

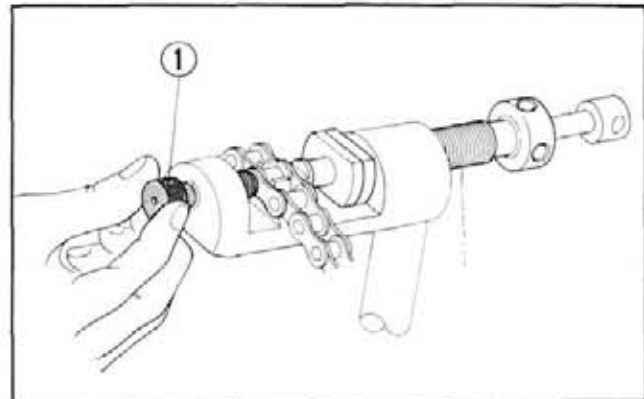


Fig. 20-43 ① Adjuster bolt

3. By use of handlebar, stake end of joint pin by turning pressure bolt B 3/4 turn.

NOTE:

Never exceed 3/4 turn.

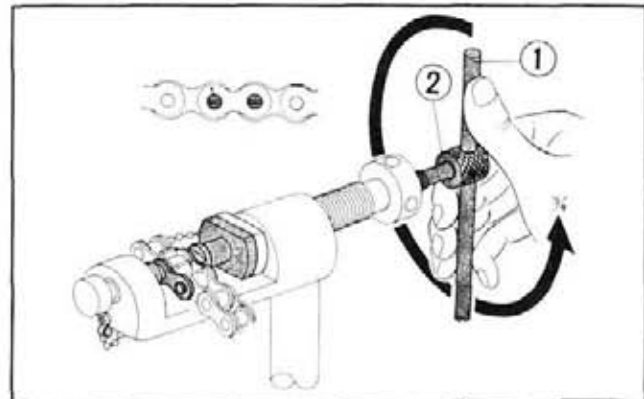


Fig. 20-44 ① Handle bar
② Pressure bolt B

4. After backing off pressure bolt A approx. two turns, back off wedge pin 1/4 turn (90 degrees) and repeat steps 1 thru 3 so that end of joint pin is staked in a cross pattern. Repeat entire steps on opposite end.

NOTE:

Be sure that cross patterned stakings be performed at 90° angles.

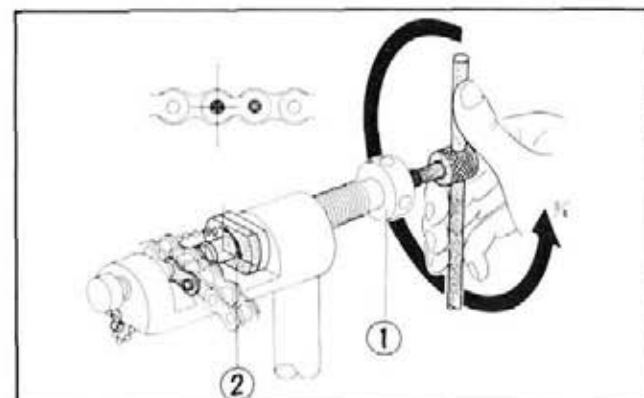


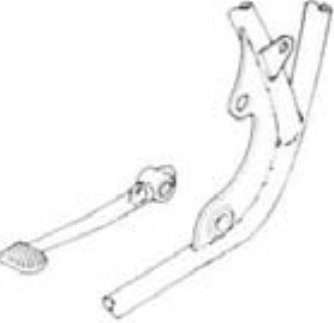
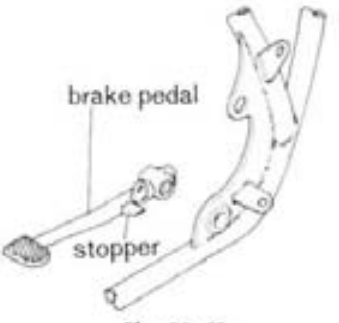
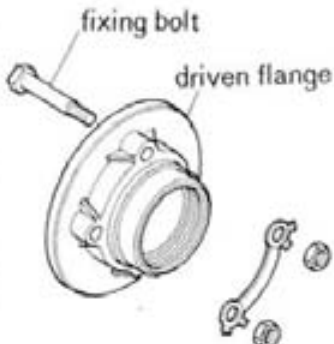
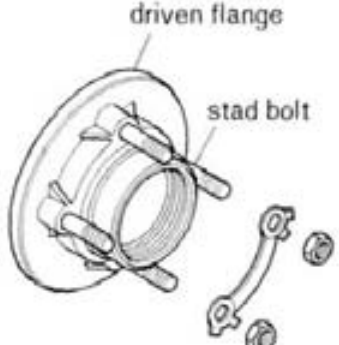


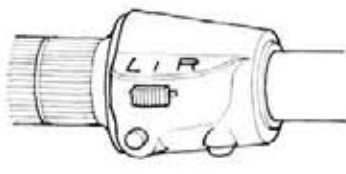
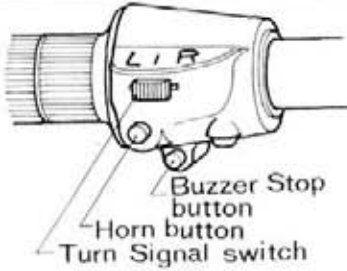
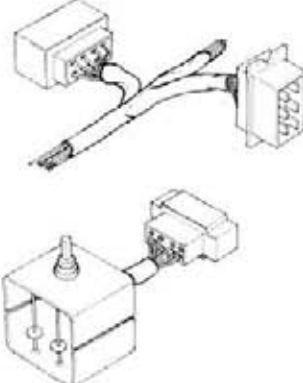
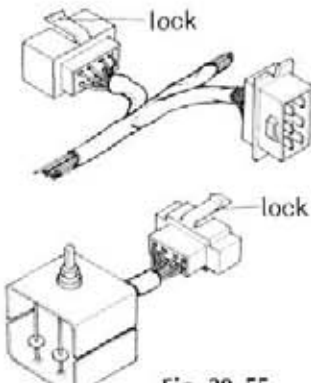
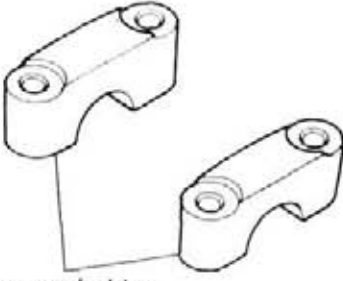
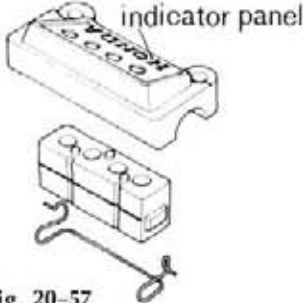
Fig. 20-45 ① Pressure bolt A
② Wedge pin

SUPPLEMENT TO CB750K1~K4

K2

COMPARISON OF CB750K2 TO CB750K1


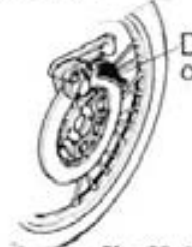
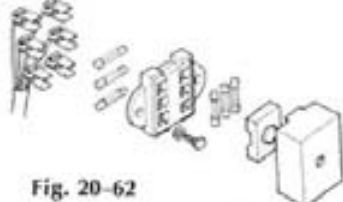
| Part of item | CB 750 K1 | CB 750 K2 | Modified part |
|---------------------------------|---|---|-------------------------|
| seat seat catch seat lock |  <p>Fig. 20-46</p> |  <p>Fig. 20-47</p> <p>The seat was changed in pattern and partially in shape. The seat catch was changed as down.</p> | seat catch seat lock |
| brake pedal |  <p>Fig. 20-48</p> |  <p>Fig. 20-49</p> <p>A stop was added to the brake pedal, returning the pedal properly.</p> | |
| driven flange |  <p>Fig. 20-50</p> |  <p>Fig. 20-51</p> <p>The fixing bolt was changed from the removable type to the press-in type.</p> | |

| Part of Item | CB 750 K1 | CB 750 K2 | Modified part |
|---|---|--|--|
| turn signal Buzzer swich |  <p>Fig. 20-52</p> |  <p>Fig. 20-53</p> <p>A turn signal buzzer was newly installed. Correspondingly a buzzer stop button was provided and the operation is described below.</p> <p>A warning buzzer which starts sounding when the switch is moved to either position is provided to prevent a rider from forgetting to return the switch after completing a turn. When a turn signal has to be kept flashing for any length of time at a crossing or the like, the buzzer can be stopped by pushing the buzzer stop button.</p> | <ul style="list-style-type: none"> • Buzzer stop switch • Turn signal buzzer |
| Wire harness and rectifier coupler lock |  <p>Fig. 20-54</p> |  <p>Fig. 20-55</p> <p>The employment of a coupler lock-assures a complete locking.</p> | |
| Indicator panel |  <p>upper holder</p> <p>Fig. 20-56</p> |  <p>indicator panel</p> <p>Fig. 20-57</p> <p>An indicator panel of the same type used in the model CB 500 was employed, grouping various control lamps for improved serviceability.</p> | |

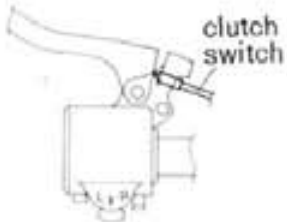
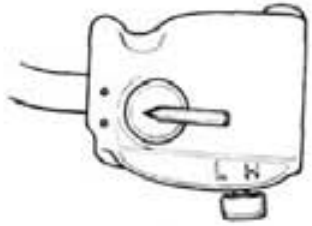
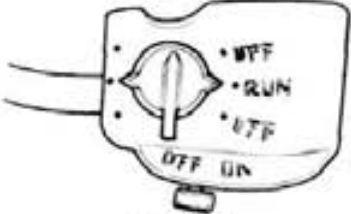
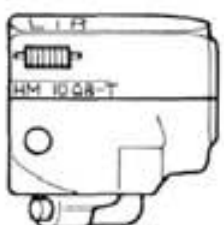
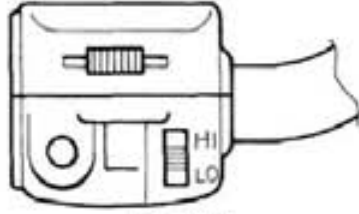
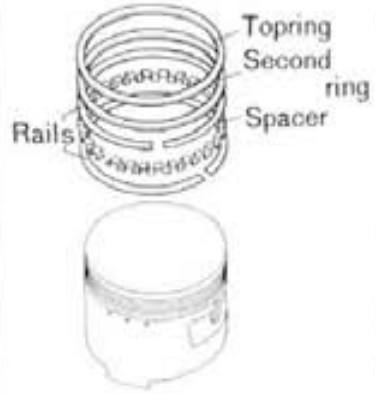


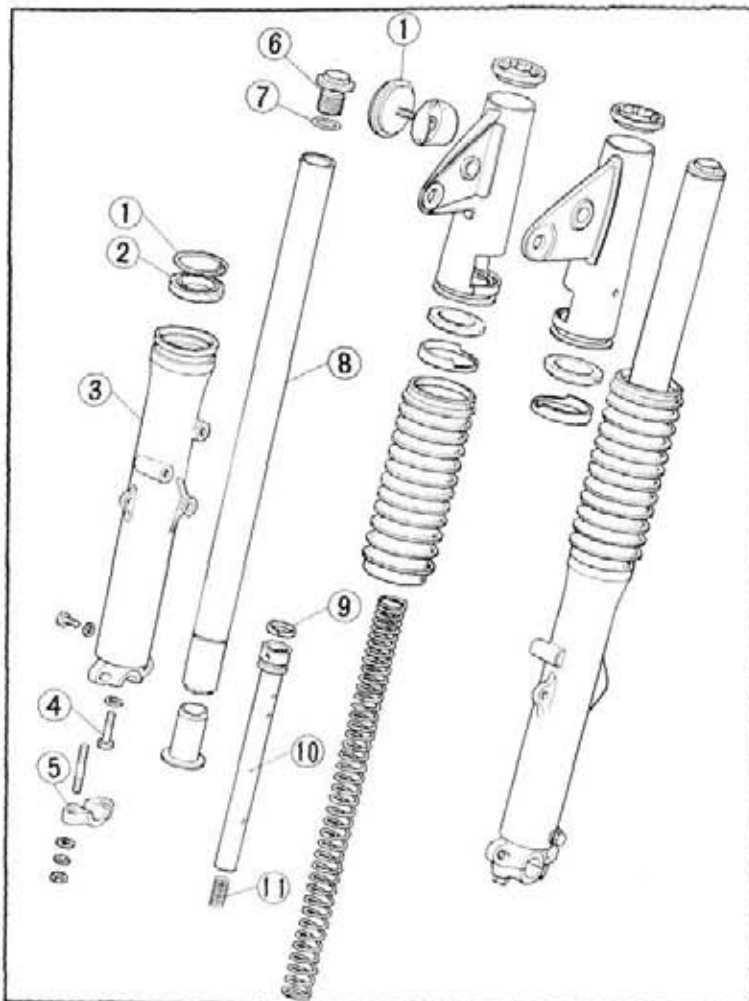
K3

COMPARISON OF CB750 K3 TO CB750 K2

| Part of item | CB 750 K2 | CB 750 K3 | Modified part |
|-----------------------------|--|--|--------------------------|
| <p>Rear shock absorbers</p> | <p>(Cross valves) Number of rear shock absorber adjusting positions increased</p> <p>Shock absorber spring adjusting positions: 3</p> | <p>(One-way valves) Shock absorber spring adjusting positions: 5 The valves were changed from the cross type to the one-way type. For the details see page 213.</p> | <p>• Shape of valves</p> |
| <p>Front forks</p> | <p>Valve in front shock absorber and its specifications changed</p> <p>Piston type valve</p> <p>Damping force: 39.5-40.5 Kg/0.5 m/sec. Stroke: 143 mm Oil capacity: 220-230 cc</p> | <p>Free valve</p> <p>Specifications</p> <p>Damping force: 34-46 Kg/0.5 m/sec. Stroke: 141.5 mm Oil capacity: 155-160 cc The valves were changed from the piston type to the free type. For the construction and function see page 212.</p> | |
| <p>Disc cover</p> | <p>Disc cover newly installed</p>  <p>Fig. 20-60</p> |  <p>Disc cover</p> <p>Fig. 20-61</p> | |
| <p>Fuses</p> | |  <p>Fig. 20-62</p> <p>The fuses were installed separately for lights such as headlight, taillight, etc. for a quick troubleshooting.</p> | |



| Part of item | CB 750 K2 | CB 750 K3 | Modified part |
|------------------------------|--|--|---|
| Safety unit Clutch switch | none |  <p>clutch switch</p> <p>Fig. 20-63</p> <p>A safety unit and a clutch switch were added to prevent the motorcycle from running out as soon as the engine starts. For the operation see page 215.</p> | |
| Lighting kill switch |  <p>Fig. 20-64</p> |  <p>Fig. 20-65</p> <p>The kill switch was changed in operating pattern from the up-down motion to the right-left motion.</p> | |
| Horn switch Dimmer switch |  <p>Fig. 20-66</p> |  <p>Fig. 20-67</p> <p>The switches were changed in shape and installation positions. The turn signal knob is of an automatic return type.</p> | |
| Oil ring |  <p>Topring Second ring Spacer Rails</p> <p>Fig. 20-68</p> | <p>The three-piece type oil ring was changed reg.</p> <ul style="list-style-type: none"> • The key points of assembling procedure are described below. <ol style="list-style-type: none"> When installing the oil ring, first place the spacer the spacer and then the rails in position. The spacer and rail gaps must be staggered above 2~3cm (0.787~1.18in.). <p>Note: The gap of the oil refers to that of the spacer.</p> | <ul style="list-style-type: none"> • Rails • Spacer |



In the model CB750K3 front shock absorbers, the valves were changed to free valves.

As its damping force can be adjusted by changing its stroke to meet a driver's preference of conditions of a road or surfaces, it always provides a comfortable ride even under severe driving conditions.

The disassembly and operation are as follows:

Fig. 20-69

- ① 48 mm Internal circlip
- ② 354811 oil seal
- ③ Front fork bottom case
- ④ 8 mm socket bolt
- ⑤ Front axle holder
- ⑥ Front fork bolt
- ⑦ 23×2.3 O ring
- ⑧ Front fork pipe
- ⑨ Piston ring
- ⑩ Bottom pipe
- ⑪ Front rebound spring

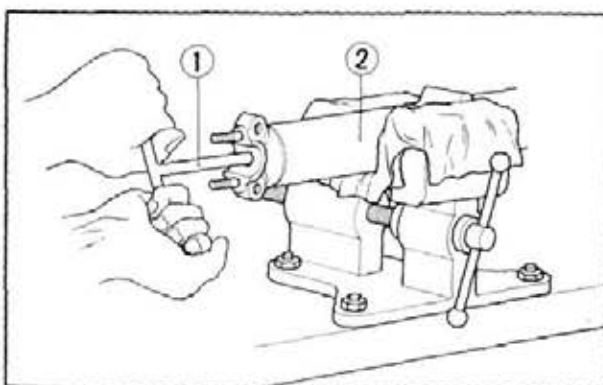


Fig. 20-70

- ① Allen head wrench
- ② Front fork bottom case

Disassembly

To disassemble the front forks, see page 120.

1. Remove the front forks by referring to page 120
2. Remove the front fork bolts and drain front shock absorber oil.
3. With each front fork bottom pipe held in a vice, remove the socket bolt using the Allen head wrench (Tool No. 0717-3230000) and separate the pipe from the bottom base.

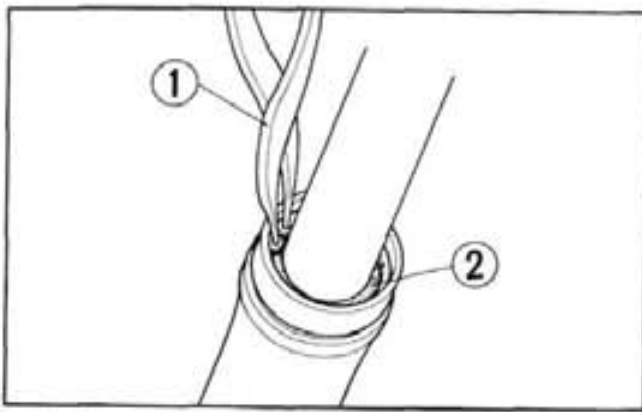


Fig. 20-71 ① 48 mm internal snap ring
② dust seal

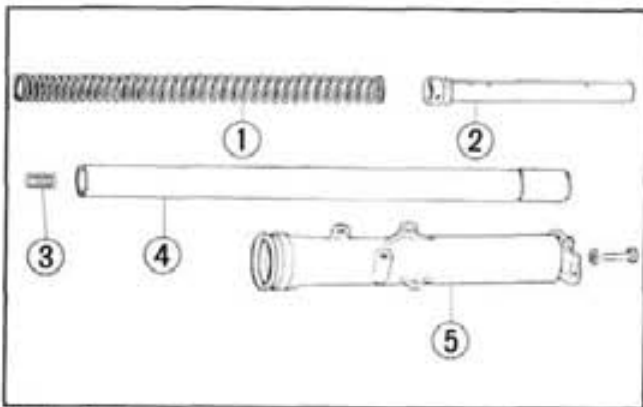


Fig. 20-72 ① Front suspension ② Bottom pipe
③ Front rebound spring
④ Front fork pipe
⑤ Front bottom case

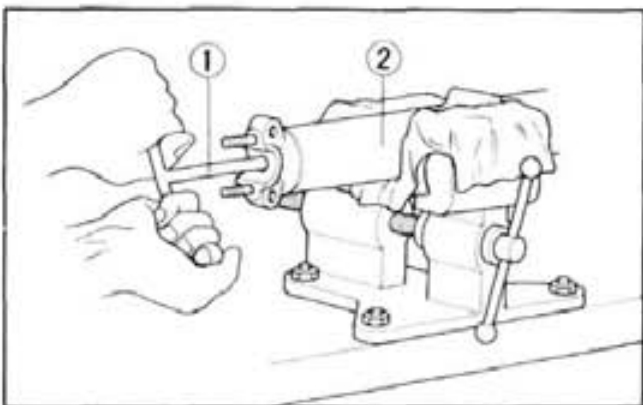


Fig. 20-73 ① Allen head wrench
② Front fork bottom case

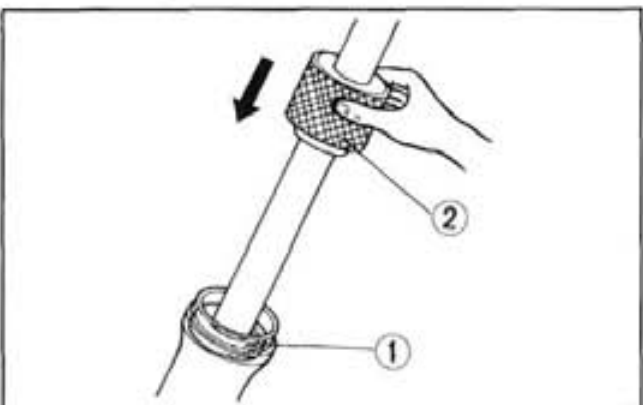


Fig. 20-74 ① Oil seal ② Fork seal driver

4. Remove the front fork dust seal, 48 mm internal circlip and oil seal.

Inspection

1. Measure the front shock absorber spring free length. Check the spring tension.
2. Check the front fork piston rings for wear.
3. Check the front fork pipe-to-bottom case clearance.
4. Check the oil seals for scores, scratches or breakage.
5. Check the sliding surfaces of the front fork pipes for scores or scratches.

Assembly

To assemble, reverse the disassembly procedures, paying attention to the following:

1. Position each fork pipe in the bottom case. Apply a coat of locking sealant to the socket bolt and tighten it with the Allen head wrench used at the time of disassembly.

2. Apply a coat of high quality ATF to the inside and outside circumferences of the oil seal and install it using the fork seal driver (Tool No. 07947-3330000).

Note:

Use a new oil seal.

3. Fill the fork pipes with high quality ATF up to the specified level.
Capacity (each fork pipe):
150~155 cc (5.3~5.5 ozs.) at the time of fork disassembly.

Operation

• When the wheel meets holes or bumps in the road, it moves up and down. This up-and-down movement of the wheel is transmitted to the bottom leg. Since the bottom leg is integrated with a pipe, the pipe also moves up and down. With either action, two springs on the pipe flux and rebound, absorbing the road to the motorcycle.

In this case, oil in the chamber (B) pushes up the free valve and flows into the space (A) freely.

At the same time, oil in the chamber (B) also flows through orifices in the lower end of the spring under seat into the space (C) by the amount by which the pipe is moved up.

• Extension

As the wheel has passed the bump or hole, it moves down. To eliminate excessive up-and-down motion of the spring and wheel, there will be a restraint on the spring and wheel action

In operation, as the wheel moves down, the free valve is closed, introducing high pressure in the space (A). This high pressure then forces the oil out and into the space (C) through the orifices in the spring under seat.

Since the oil encounters a restraint as it passes through the orifices, excessive wheel and spring movement as well as spring oscillation are prevented.

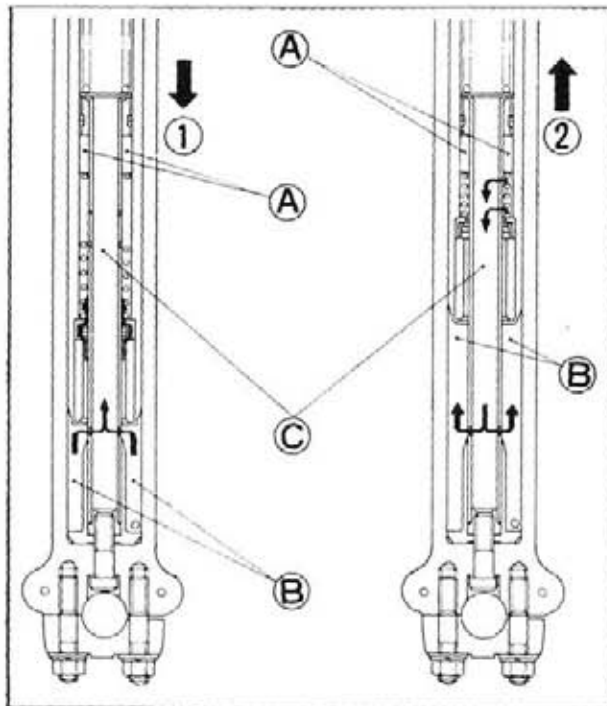


Fig. 20-75 ① Compression ② Extension

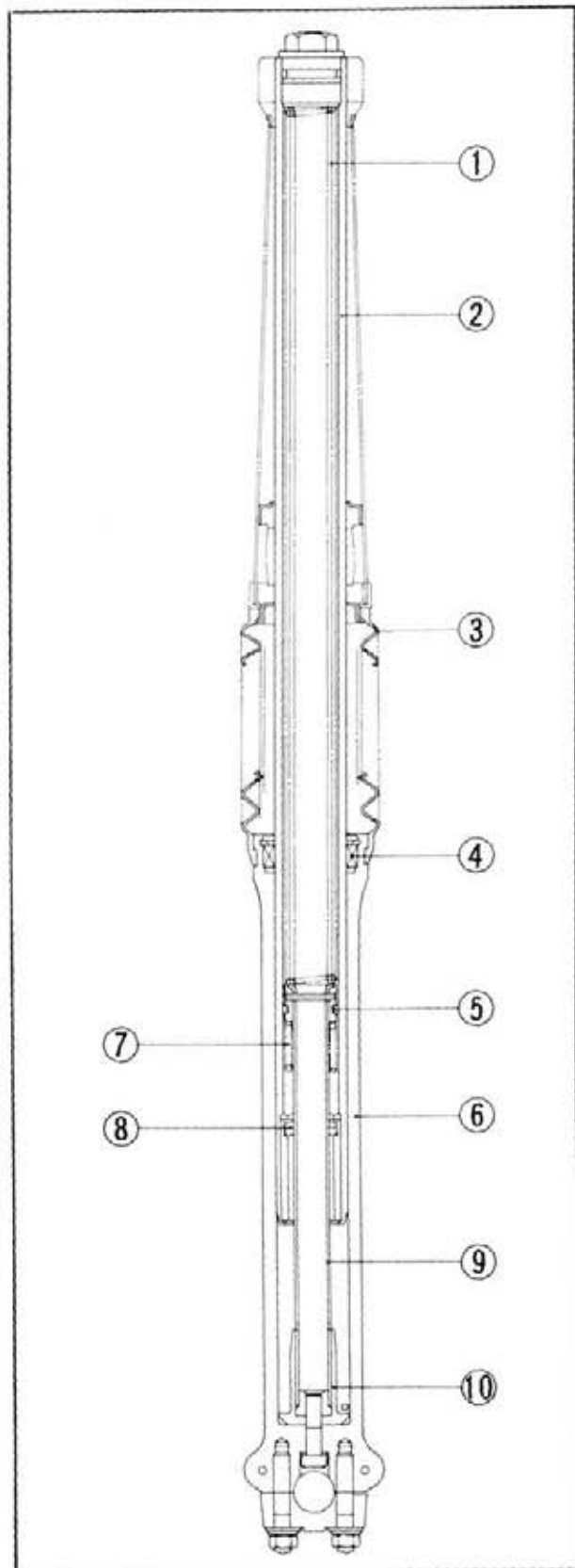


Fig. 20-76 ① Front spring ② Front fork pipe ③ Front fork dust seal ④ Oil seal ⑤ Piston ring ⑥ Front fork bottom leg ⑦ Front rebound spring ⑧ Free valve seal ⑨ Bottom pipe ⑩ Oil lock piece

Rear Shock Absorbers (cross valve)

Each rear shock absorber uses a double-cylinder, cross type oil damper a bottom valve, preventing occurrence of air bubbles to provide a constant damping force. On both the extension and compression sides, the characteristic of damping force is excellent and the damping efficiency is higher.

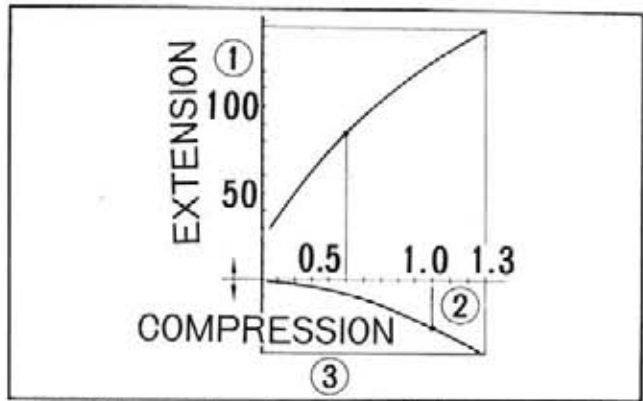


Fig. 20-77 ① Damping force (kg)
② Piston speed (m/s)
③ Characteristic of damping force

Operation

Each oil damper is equipped with piston valves A and B and a bottom valve. The damping force is provided by means of the valve A on the extension side, and the resistances on the bottom valve side and in the passage II on the compression side.

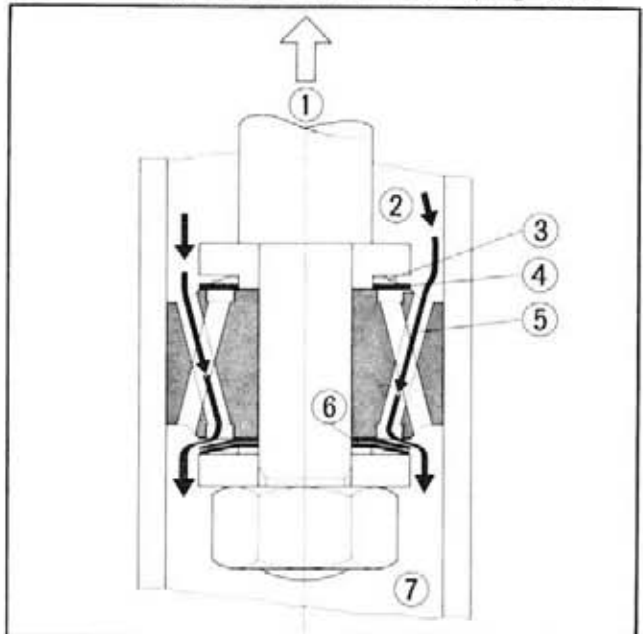


Fig. 20-78 ① Extension side ⑤ Passage I
② Chamber "a" ⑥ Valve B
③ Valve spring ⑦ Chamber "b"
④ Valve B

• Extension side

When oil attempts to flow from the chamber "a" to the chamber "b", the valve B is closed. Then the oil passes through the passage I to force the valve A to open, and the damping force is provided by the resistance of the valve. (Fig. 20-79) At this time the bottom valve is open, and the oil passes through the chamber "c" and passage III to lift up the bottom valve spring and flows into the chamber "b" from the bottom of the valve. (Fig. 20-81)

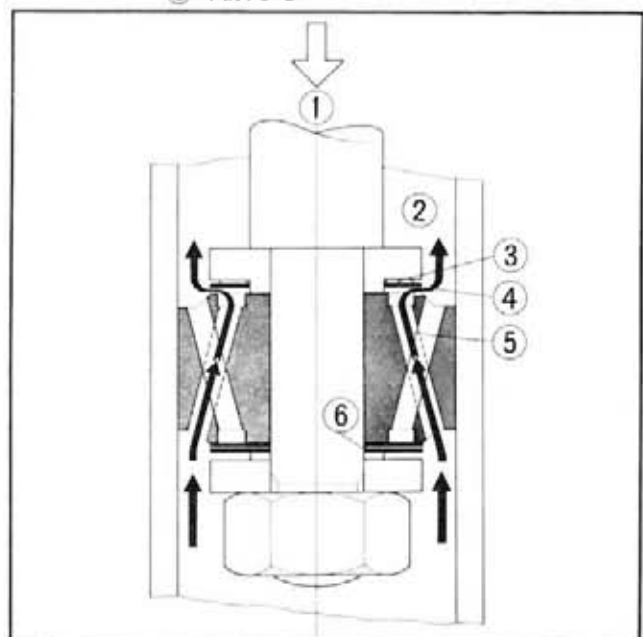


Fig. 20-79 ① Compression side ④ Valve B
② Chamber "a" ⑤ Passage II
③ Valve spring ⑥ Valve A

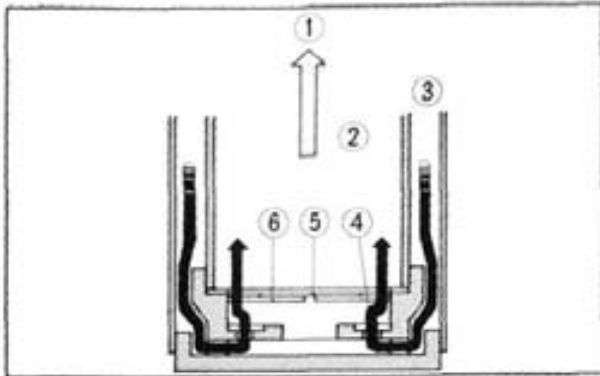


Fig. 20-80 ① Extension side ⑤ Bottom valve spring
 ② Chamber "b" ⑥ Bottom valve
 ③ Chamber "c" ④ Passage III

• Compression side

When oil attempts to flow from the chamber "b" to the chamber "a", the valve A is closed. Then the oil passes through the passage II to cause the valve B to lift up the valve spring and flows into the chamber "a" from the bottom of the valve. (Fig. 20-80)

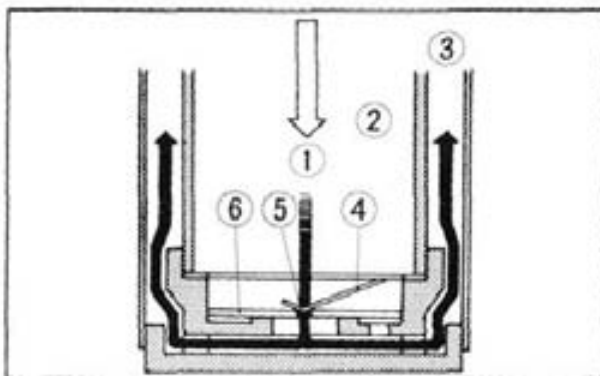


Fig. 20-81 ① Compression side ④ Bottom valve spring
 ② Chamber "b" ⑤ Orifice
 ③ Chamber "c" ⑥ Bottom valve

A small quantity of damping force may be provided by the resistance of the valve spring, but a large quantity of the force can be provided by the resistance on the bottom valve side. The oil in the chamber "b" flows by the amount corresponding to the volume of rod into the chamber "c" through the orifice I and the damping force is provided by the resistance at this time. (Fig. 20-81)

2. STARTING MOTOR SAFETY UNIT

• Description

The starting motor safety unit operates in the way that the starting motor functions only when the transmission is in neutral or while the clutch lever is being squeezed in any gear position, assuring rider safety and preventing damage of the motor and transmission gears.

• Circuits and operations

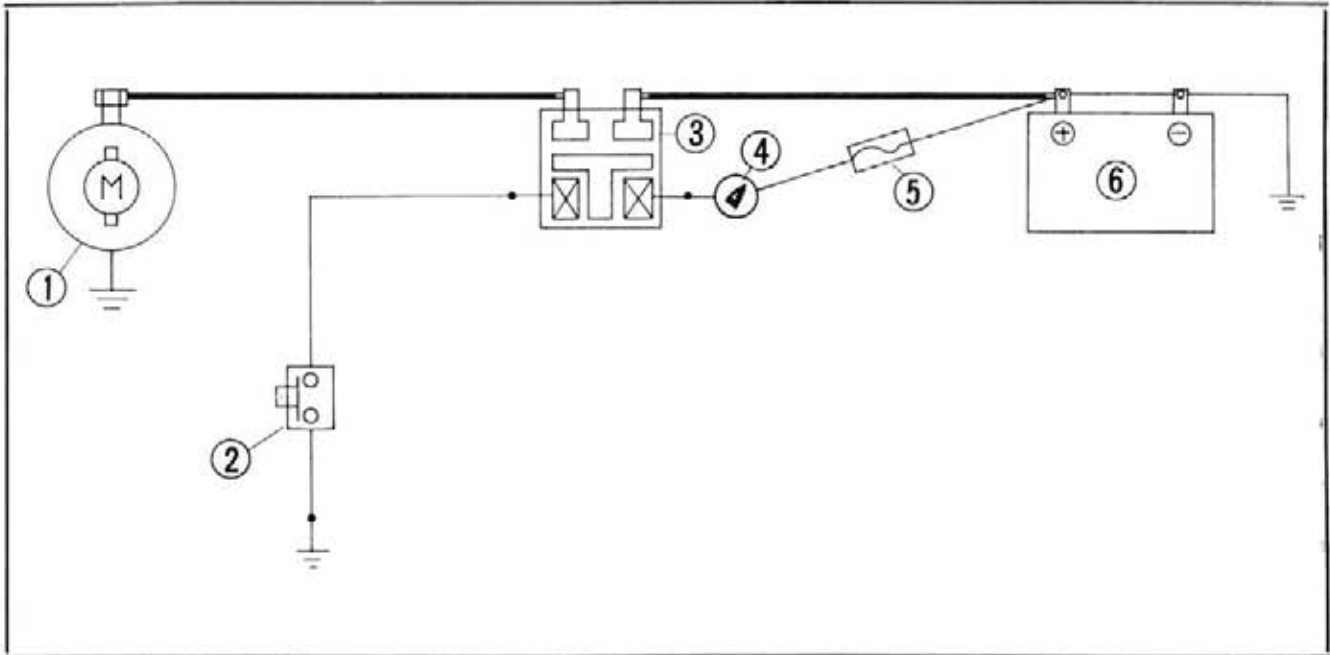


Fig. 20-82 Circuit of models without safety unit

- | | |
|---------------------------|---------------|
| ① Starting motor | ④ Main switch |
| ② Starter button switch | ⑤ Fuse |
| ③ Starter magnetic switch | ⑥ Battery |

When the engine switch is turned on, some amount of electricity is usually applied to the starter magnetic switch coil. If the starter button switch is then turned on, the starter magnetic switch will operate to cause the starting motor to turn. In other words, the motorcycle begins to move when the main switch and starter button switch are turned on with the transmission in gear.

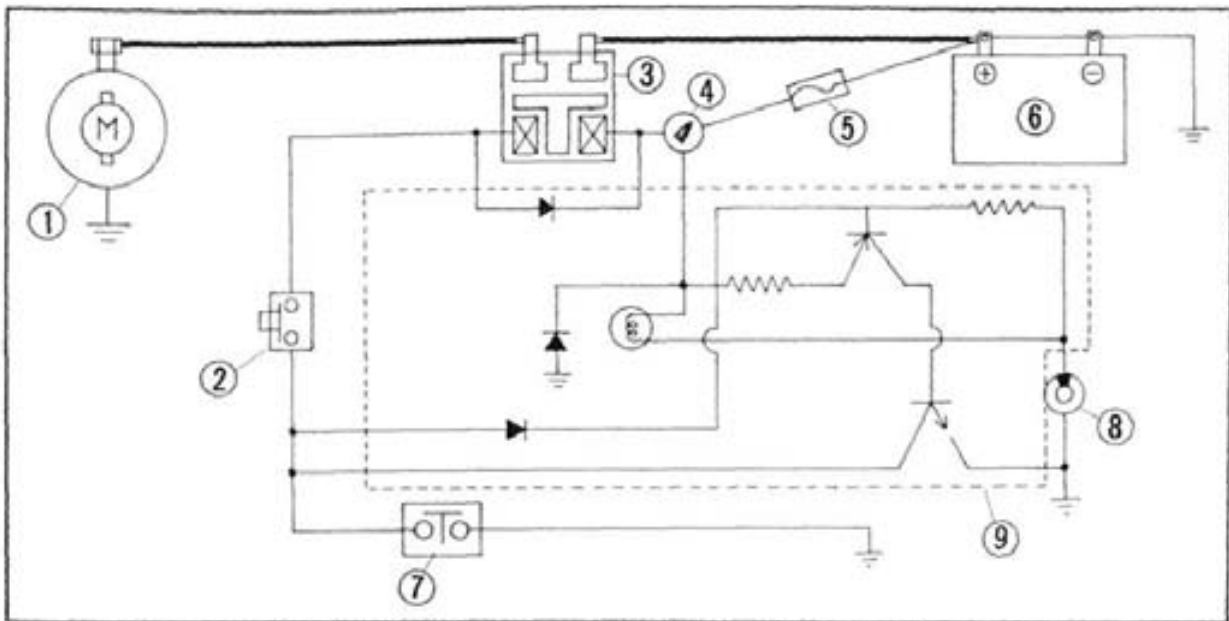


Fig. 20-83 Circuit of model (CB 750) with safety unit

- | | |
|---------------------------|-----------------------|
| ① Starting motor | ⑥ Battery |
| ② Starter button Switch | ⑦ Clutch lever switch |
| ③ Starter magnetic switch | ⑧ Neutral switch |
| ④ Main switch | ⑨ Safety unit |
| ⑤ Fuse | |

The ground side of the starter button switch is connected to the body through the clutch lever switch and neutral switch. When the clutch lever switch or the neutral switch is turned on the starter magnetic switch will operate to cause the starting motor to turn.

(1) Clutch lever switch

The clutch lever switch is designed to be turned on when the clutch lever is squeezed to cause the clutch to be disengaged only. (This switch has the same construction and function as those of the front stop switch.)

3. 3-CIRCUIT FUSES

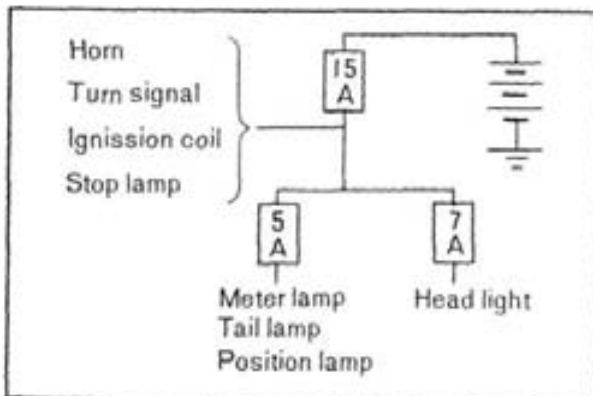


Fig. 20-84

In a conventional 1-circuit fuse, if it burns out, the engine cannot be started.

The 3-circuit fuses contain a 15A main fuse and two 7A and 5A sub-fuses, one for the headlight and the other for the position lamp, taillight and meter lamp. Even if the 7A fuse or 5A fuse or both burn out, the horn, turn signals, ignition switch and stop-light operate properly. However, it is wise to locate the cause of trouble and replace a damaged fuse with new one as soon as possible. The fuses are set in the fuse box which is taken out by opening the seat.

4. BRAKE LINING WEAR INDICATOR

Discription

The brake lining wear indicator is provided to check the wear condition of the brake linings visually from outside. As shown in the figure below, the indicator plate is attached to the brake cam. As the brake lining has worn, brake cam moves excessively. Such a movement of the cam is checked by the arrow on the periphery of the indicator. Further the brake panel cam boss is provided with the "wear limit" mark to make it possible to check the service limit (replacement time) of the lining easily with the brake panel installed.

Descriptive illustration

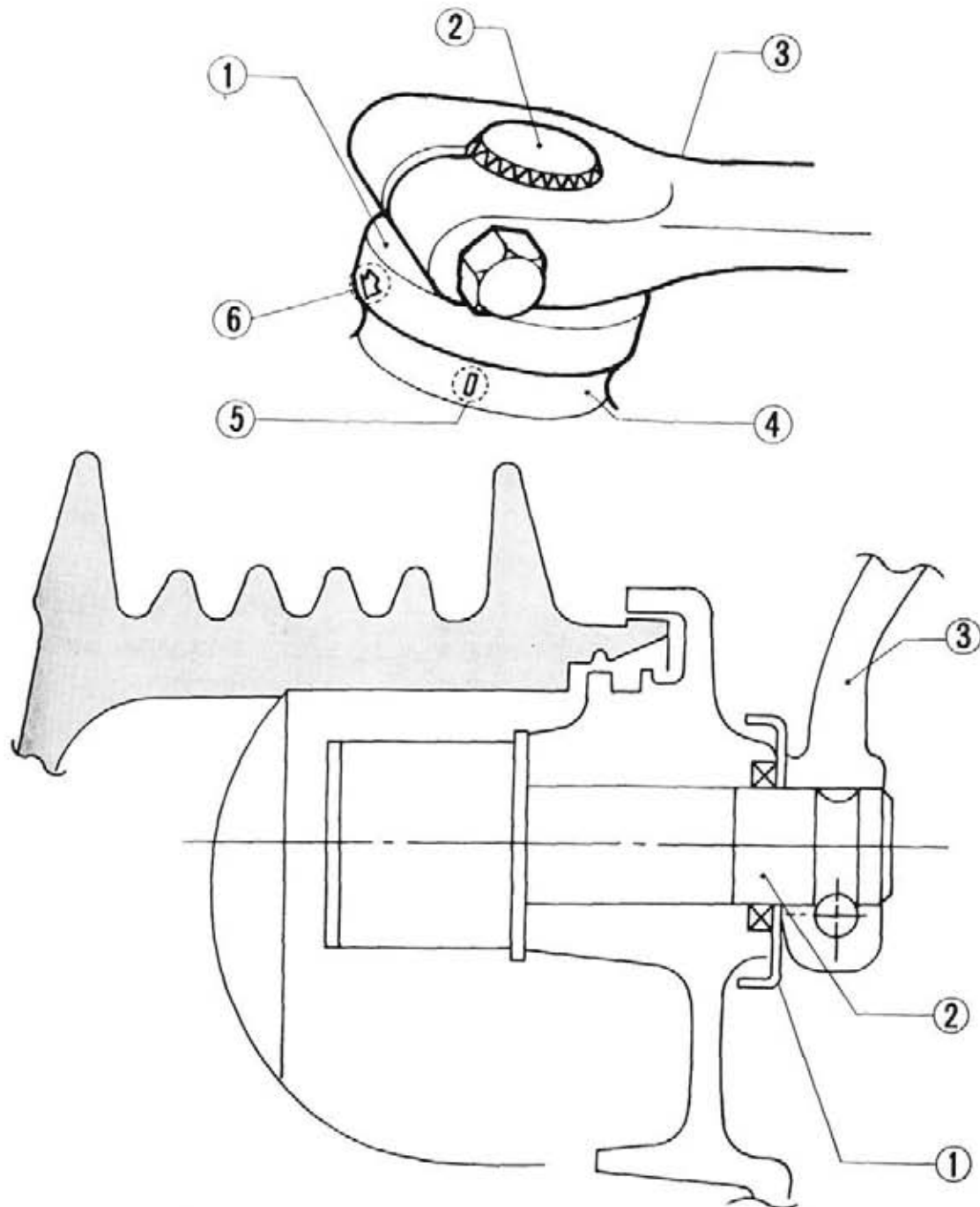


Fig. 20-85 ① Indicator plate
 ② Brake cam
 ③ Brake arm
 ④ Brake panel cam boss
 ⑤ "Wear limit" mark
 ⑥ Arrow

5. REAR SHOCK ABSORBER ASSEMBLIES

(K4 to K2 model)

The rear shock absorber assemblies feature the telescopic type oil dampers with bottom valve to give an optimum damping performance under all bumping and rebounditions. The damping performance on the extension side is well matched with that on the compression side, providing maximum damping.

Stroke of rear shock absorber: 86.3 mm (3.39 in.)

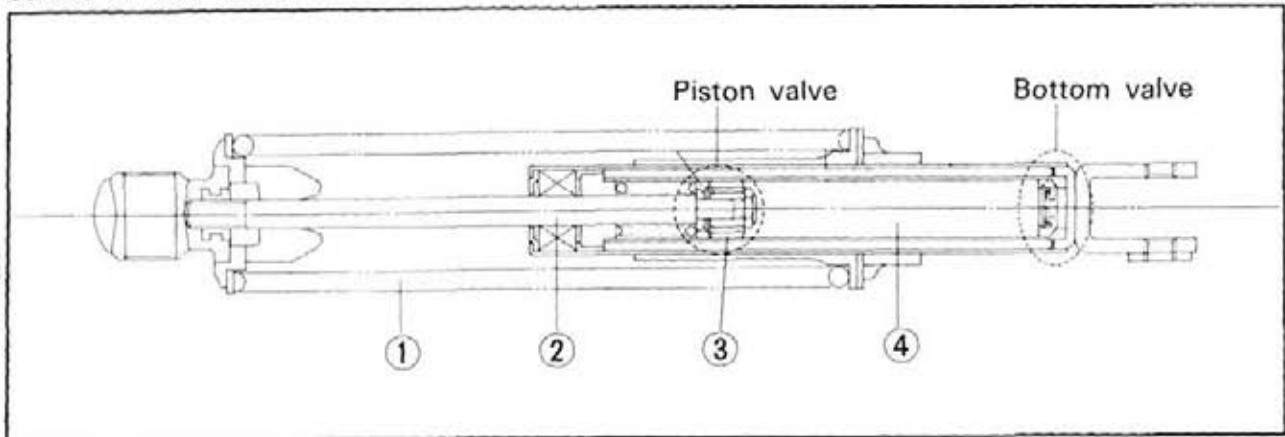


Fig. 20-86 ① Rear shock absorber spring ② Damper rod
③ Damper piston ④ Damper cylinder

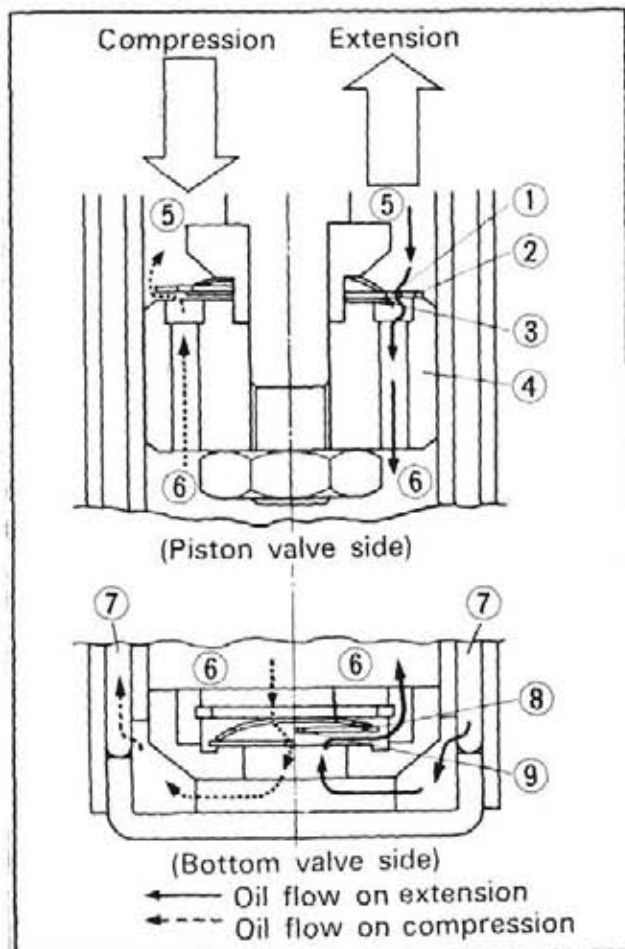


Fig. 20-87 ① Orifice (I) ② Valve "A"
③ Valve "B" ④ Piston
⑤ Chamber "a" ⑥ Chamber "b"
⑦ Chamber "c" ⑧ Bottom valve
⑨ Orifice (II)

Operation

Each oil damper is equipped with the piston valves A and B and bottom valve. On the extension side,, the damping action is provided by means of the piston valves. While, on the compression side, the damping action is provided by means of the bottom valve.

On extension side:

The oil in the chamber [a] flows into the chamber [b] through the orifice (I) in the valve A (sheet metal). By the resisting force of this oil, the damping action is provided. The valve A is overlapped with the valve B (leaf spring) which covers the half of the orifice. The damping action is regulated by the deflection of the valve B. Under such a condition, the bottom valve is opened and the oil in the chamber [c] flows into the chamber [b] smoothly to prevent air bubbles from being produced.

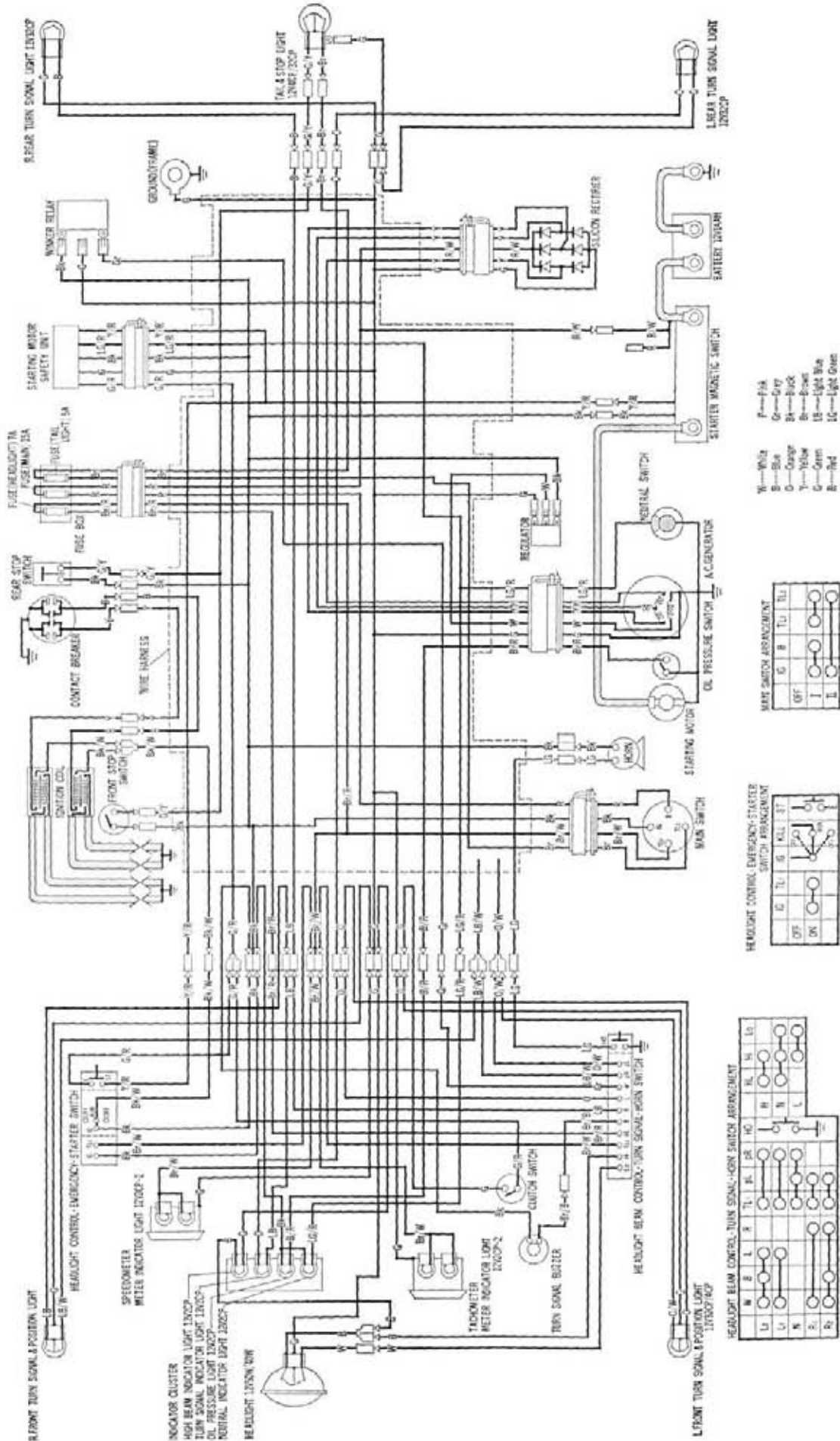
On compression side:

The oil in the chamber [b] flows by amount of oil equivalent to the volume of damper rod into the chamber [c] through the orifice in the bottom valve. By the resisting force of this oil, the damping action is provided. At this time the piston valves are opened and the oil flows from the chamber [b] into the chamber [a] smoothly.

K4**COMPARISON OF CB750 K3 TO CB750 K4**

| Part of item | CB 750 K3 | CB 750 K4 | Modified part |
|--------------|-----------|---|---------------|
| | | The stripes on the fuel tank are changed. | |

CB 750 K4 WIRING DIAGRAM



1. FUEL COCK

The fuel cock is new for the revised model. Concurrent with this change, the indication marks and their positions on fuel cock was changed. It was also relocated from the right to the left side of the fuel tank.

Inspection and cleaning

1. Place the fuel lever in the "OFF" position; disconnect the fuel tube. Take out the fuel tank.
2. Drain the fuel tank thoroughly.
3. Loosen the fuel cock fixing nut and then remove the fuel cock and fuel filter from the fuel tank.
4. Check the gasket to see if it is not damaged. Replace with a new one, if found to be damaged too badly beyond use.
5. Wash the fuel filter in solvent and dry with compressed air. Any slightest damage cannot be tolerated here. Also replace the filter with a new one if found to be clogged.
6. Install the fuel filter to the fuel cock with the fixing nut. Do not forget to install the gasket into the groove of the fixing nut.
7. Install the fuel cock to the fuel tank with the fixing nut.
8. Install the fuel tank in place on the frame; connect tube and secure with the clip.
9. Fill the tank with fuel. With the fuel cock lever in the "ON" position, check for any leakage past the tube joints or connections.

2. THROTTLE GRIP

The throttle grip adjuster, Fig. K5-3, hitherto offered, was discontinued.

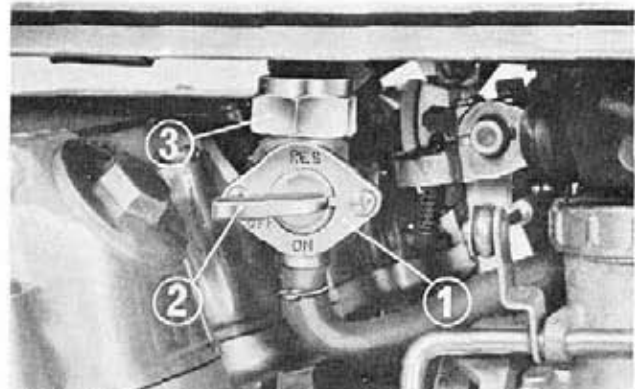


Fig. K5-1 ① Fuel cock ② Lever ③ Fuel cock fixing nut

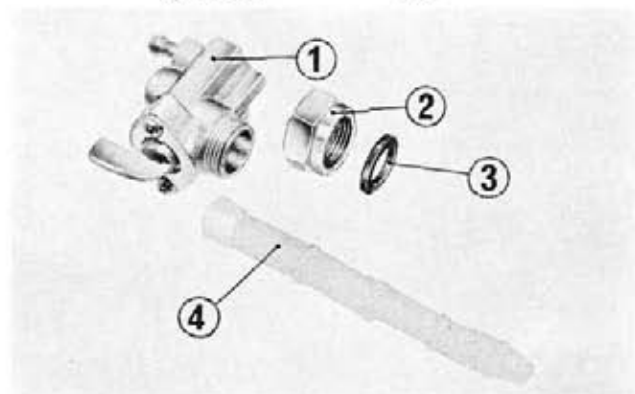


Fig. K5-2 ① Fuel cock ② Fixing nut ③ Gasket ④ Fuel filter

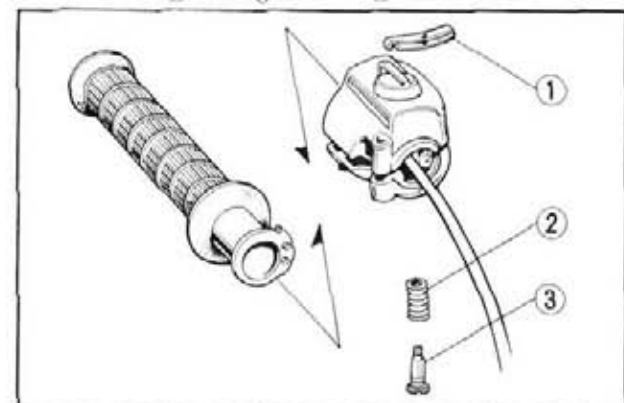


Fig. K5-3 ① Throttle grip adjuster ② Spring ③ Adjusting bolt

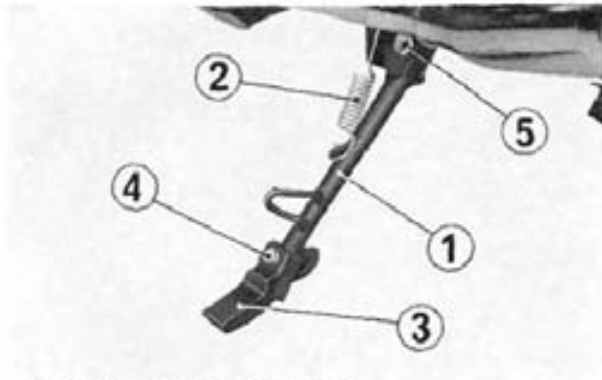


Fig. K5-4 ① Side stand bar
② Spring
③ Rubber pad
④ 6mm bolt
⑤ Side stand pivot bolt

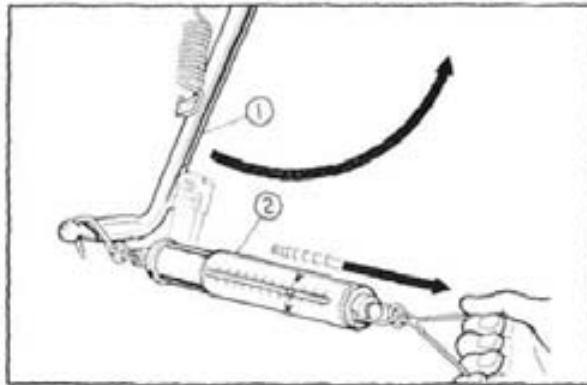


Fig. K5-5 ① Side stand bar
② Spring scale

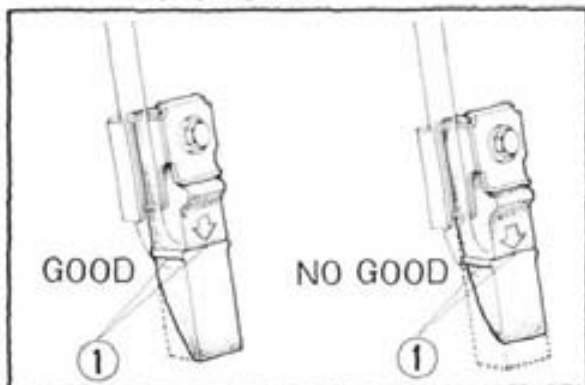


Fig. K5-6 ① Wear line

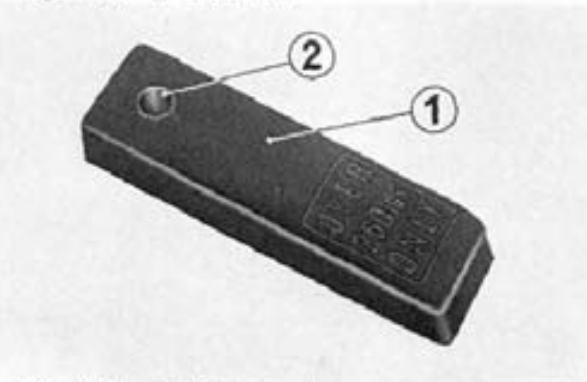


Fig. K5-7 ① Rubber pad
② Collar

3. SIDE STAND

The side stand was changed to a new type with a shock absorbing rubber pad. The stand *must* be inspected periodically to determine that it is in good condition.

Inspection

1. Check the entire stand assembly (side stand bar, bracket and rubber pad) for installation, deformation or otherwise excessive damage.
2. Check the spring for freedom from damage or other defects.
3. Check the side stand for proper return operation:
 - a. With the side stand applied, raise the stand off the ground by using the main stand.
 - b. Attach a spring scale to the lower end of the stand and measure the force with which the stand is returned to its original position.
 - c. The stand condition is correct if the measurement falls within 2-3 kg (4.4-6.6 lbs.).

If the stand requires force exceeding the above limit, this might be due to neglected lubrication, overtightened side stand pivot bolt, worn stand bar or bracket, or otherwise excessive tension. Repair as necessary.

4. Check the rubber pad for deterioration or wear.

When the rubber pad wear is excessive so that it is worn down to the wear line, replace it with a new one.

Rubber pad replacement

1. Remove the 6mm bolt; separate the rubber pad from the bracket at the side stand.
2. After making sure the collar is installed, put a new rubber pad in place in the bracket with the arrow mark out.

NOTE: Use rubber pad having the mark "OVER 260 lbs. ONLY".

3. Secure the rubber pad with the 6mm bolt.

4. TURN SIGNAL LIGHT

The front and rear turn signal lights were changed to new, larger types See Figs. K5-8 and K5-9.

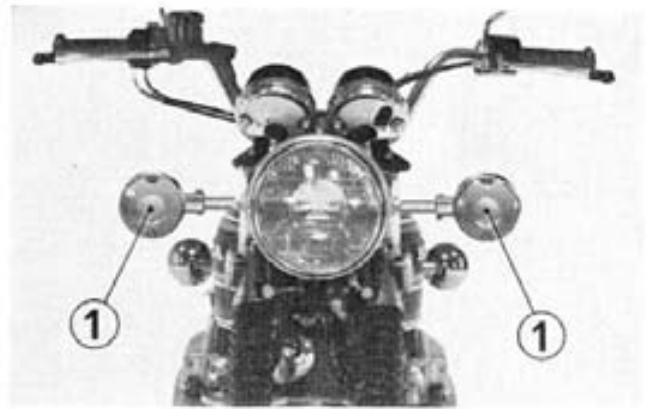


Fig. K5-8 ① Front turn signal light

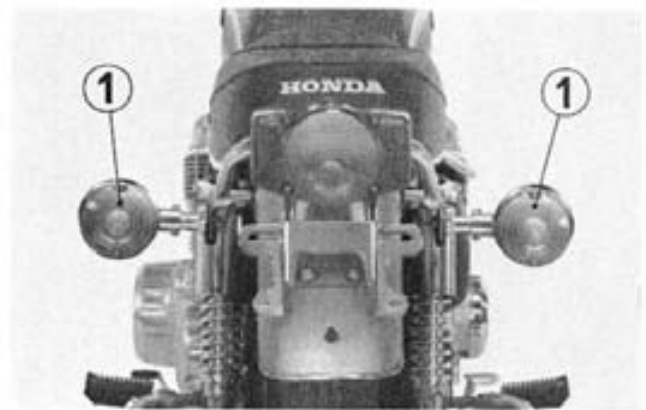


Fig. K5-9 ① Rear turn signal light

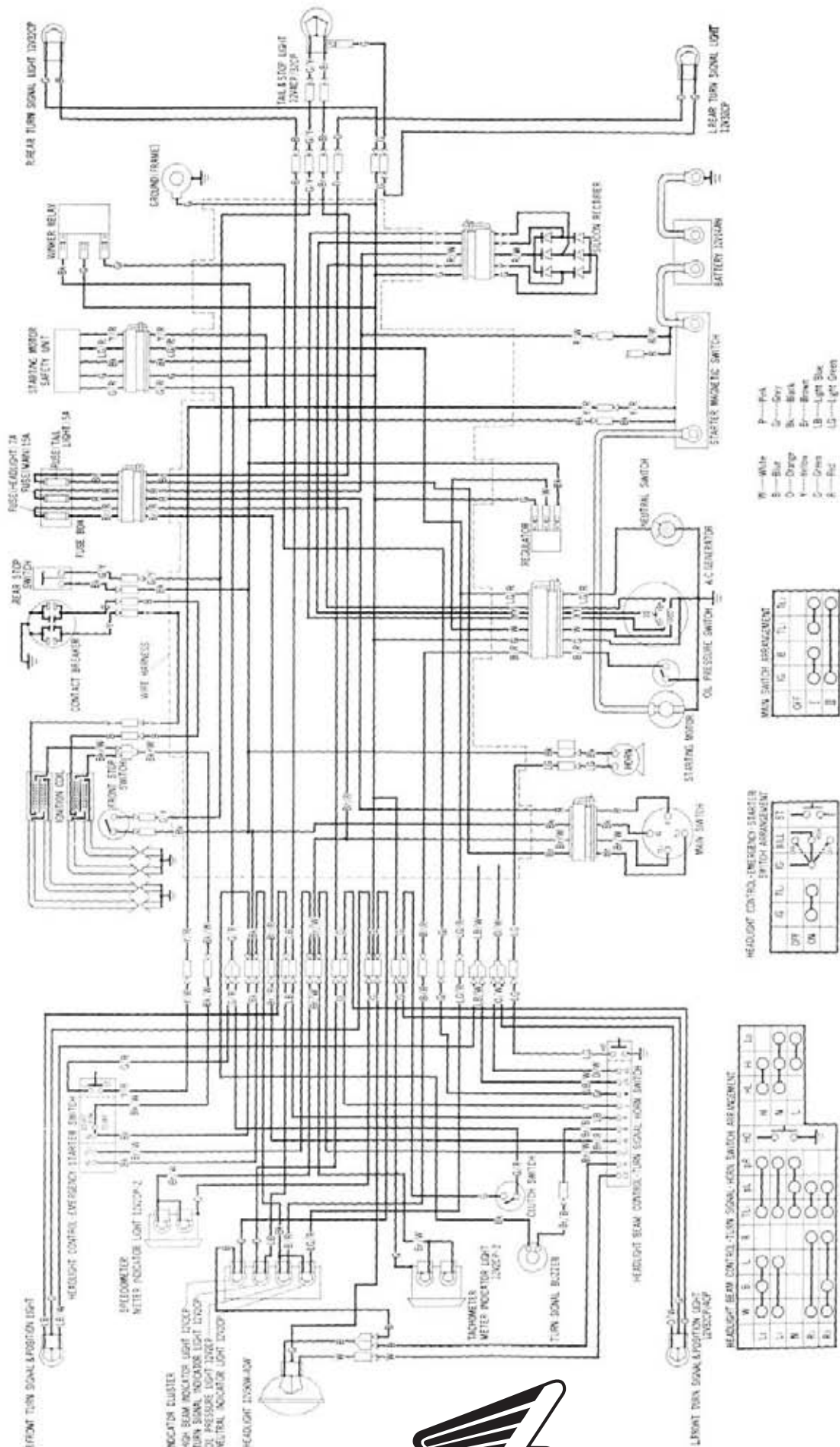
5. MAINTENANCE SCHEDULE

Some additions occurred in the MAINTENANCE SCHEDULE, of which details are as shown immediately below:

| MAINTENANCE SCHEDULE This maintenance schedule is based upon average riding conditions. Machines subjected to severe use, or ridden in unusually dusty areas, require more frequent servicing. | INITIAL SERVICE PERIOD | REGULAR SERVICE PERIOD Perform at every indicated month or mileage interval, whichever occurs first. | | | |
|---|------------------------|---|-------------|-------------|-------------|
| | | 1 month | 3 months | 6 months | 12 months |
| | 500 miles | 500 miles | 1,500 miles | 3,000 miles | 6,000 miles |
| *SIDE STAND—Check installation, operation, deformation, damage and wear. | | | | ○ | |

Items marked * should be serviced by an authorized Honda dealer, unless the owner has proper tools and is mechanically proficient. Other maintenance items are simple to perform and may be serviced by the owner.

6. WIRING DIAGRAM



1. Carburetor Setting:

| Item | CB750F |
|--------------------|--------------|
| Setting mark | CB750F |
| Venturi dia. | 28 ϕ mm |
| Main jet | 105 |
| Air jet | 120 |
| Slow jet | 40 |
| Air screw opening | 1 \pm 3/8 |
| Cutaway | 2.5 |
| Valve seat dia. | 2.0mm |
| Fuel level | 26mm |
| Jet needle setting | Third notch |

MUFFLER

Disassembly

1. Remove the two bolts ① securing the muffler in position.
2. Remove the eight joint nuts and take out the exhaust pipe joint, joint collar and muffler as an assembled unit.
3. Loosen off the muffler band clamp bolt; remove the two exhaust pipes and sealing gaskets off the muffler.

Inspection

1. Check the muffler for damage or other defects.
2. Check the exhaust pipe gasket for condition.
3. Examine if the muffler sealing gasket is in good condition and is not damaged or broken.

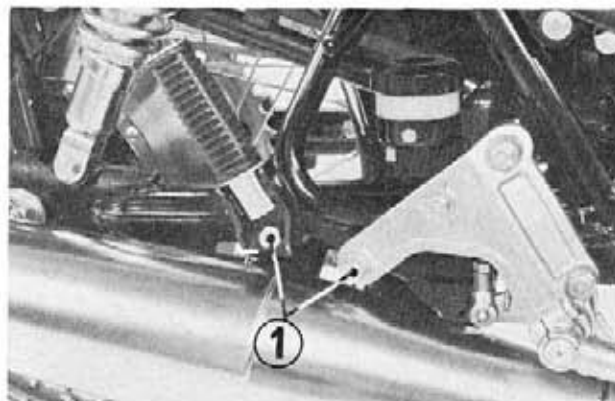


Fig. 1 ①

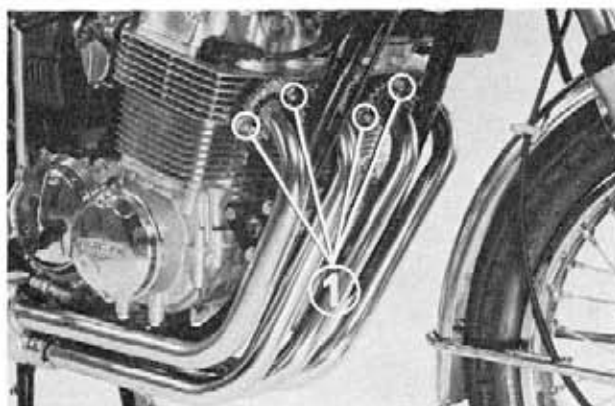


Fig. 2 ① Joint nuts

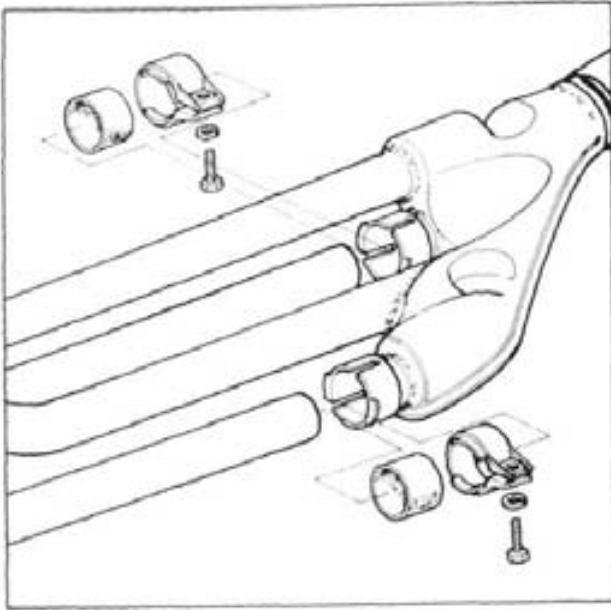


Fig. 3 ①

Assembly

1. Install the muffer before attaching the two exhaust pipes.
2. Put the sealing gasket on the exhaust pipe, and then assemble the pipe to the muffer.
3. Fasten the exhaust pipe to the cylinder with the joint and joint collar in between.
4. Install the muffer band so that the band clamping bolt is exactly down on the muffer.

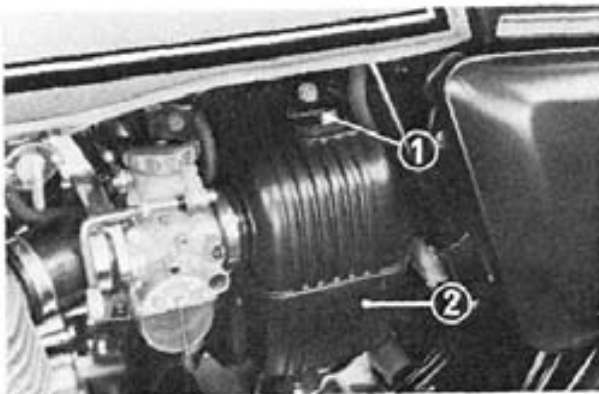


Fig. 4 ① Air cleaning mounting bolt
② Air cleaner lower case

Air Cleaner Maintenance

1. Remove the two air cleaner mounting bolts ① and remove the air cleaner lower case ②.

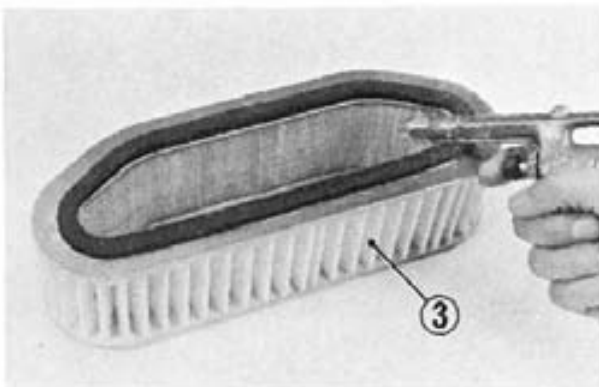


Fig. 5 ③ Air cleaner element

2. Clean the air cleaner element by tapping it lightly to loosen dust. The remaining dust can be brushed from the outer element surface or blown away by applying compressed air from the inside of the element.

3. Remove the 6mm breather element case mounting bolt (4) and remove the breather element.
4. Remove the two screws (6) and pull out the breather element (7) from the breather element case.
5. Wash the breather element (7) in clean solvent.
Squeeze out excess solvent and then dry the element thoroughly.

WARNING: Gasoline or low flash point solvents are highly flammable and must not be used to clean the breather element.

6. To reinstall the air cleaner, reverse the removal procedure.

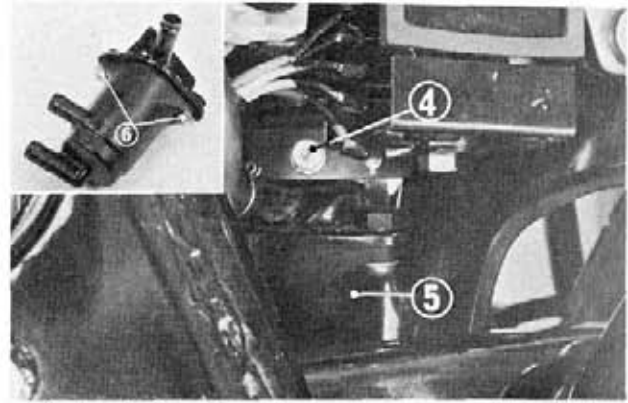


Fig. 6 (4) Breather element case mounting bolt (5) Breather element case (6) Screws

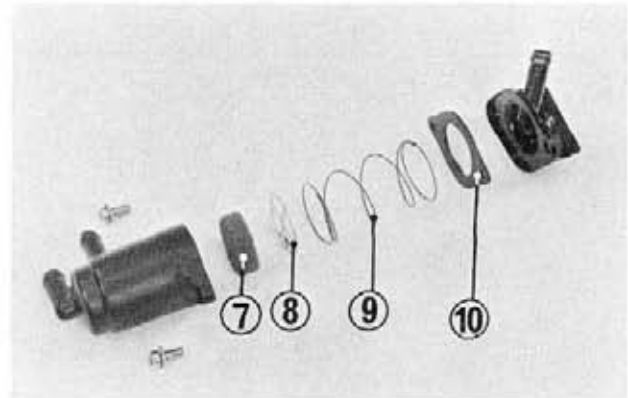


Fig. 7 (7) Breather element (8) Element retaining plate (9) Spring (10) Cover gasket

FRONT BRAKE

Disassembly

Caliper

1. Remove the caliper as an assembled unit.
2. To separate the calipers A and B, remove the caliper setting bolts.
To service the calipers mounted on the motorcycle, remove the oil pipe from the caliper beforehand.

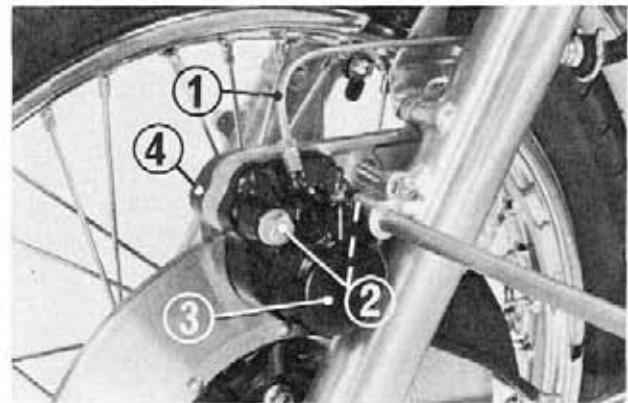


Fig. 8 (1) Oil pipe (2) Caliper setting (3) Caliper A (4) Caliper B

With the wheel bearing in place insert the axle shaft through the bearing. Place the axle shaft on V blocks, holding the wheel vertical. Check carefully for runout while rotating the wheel by hand.

| | Standard value | Service limit |
|----------------|----------------|---------------|
| Surface runout | 0.5mm max. | 2.0mm min. |
| Radial runout | 0.5mm max. | 2.0mm min. |

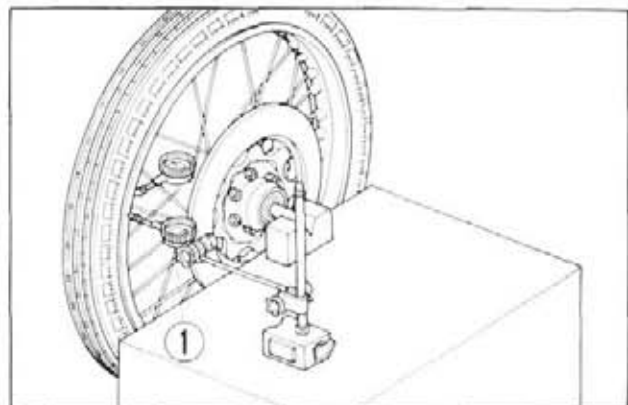


Fig. 9 (1) Dial gauge

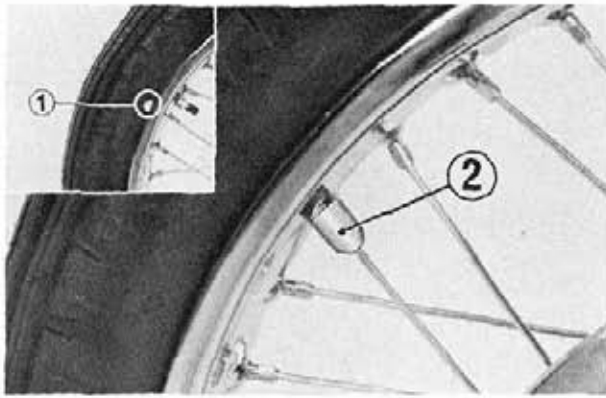


Fig. 10 ① Balancing mark
② Balancing weight

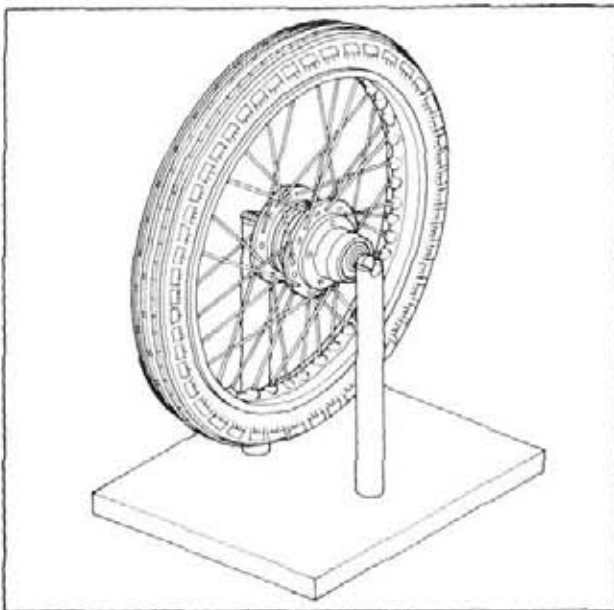


Fig. 11

Balancing the Front Wheel

1. Remove the front wheel.
2. Remove the speedometer gear box.
3. Remove the front wheel collars.
4. Remove the front brake disc.
5. Insert the axle shaft through the wheel and place the shaft on V blocks.
6. Make three chalk marks on the wheel and spin by hand, allowing the heavy part to roll to the bottom.
7. Attach compensating weights to the top section, and again spin the wheel to check the result.
8. The weights should be installed to the spoke. The following four weights are available: 5g, 10g, 15g and 20g.

REAR FORK

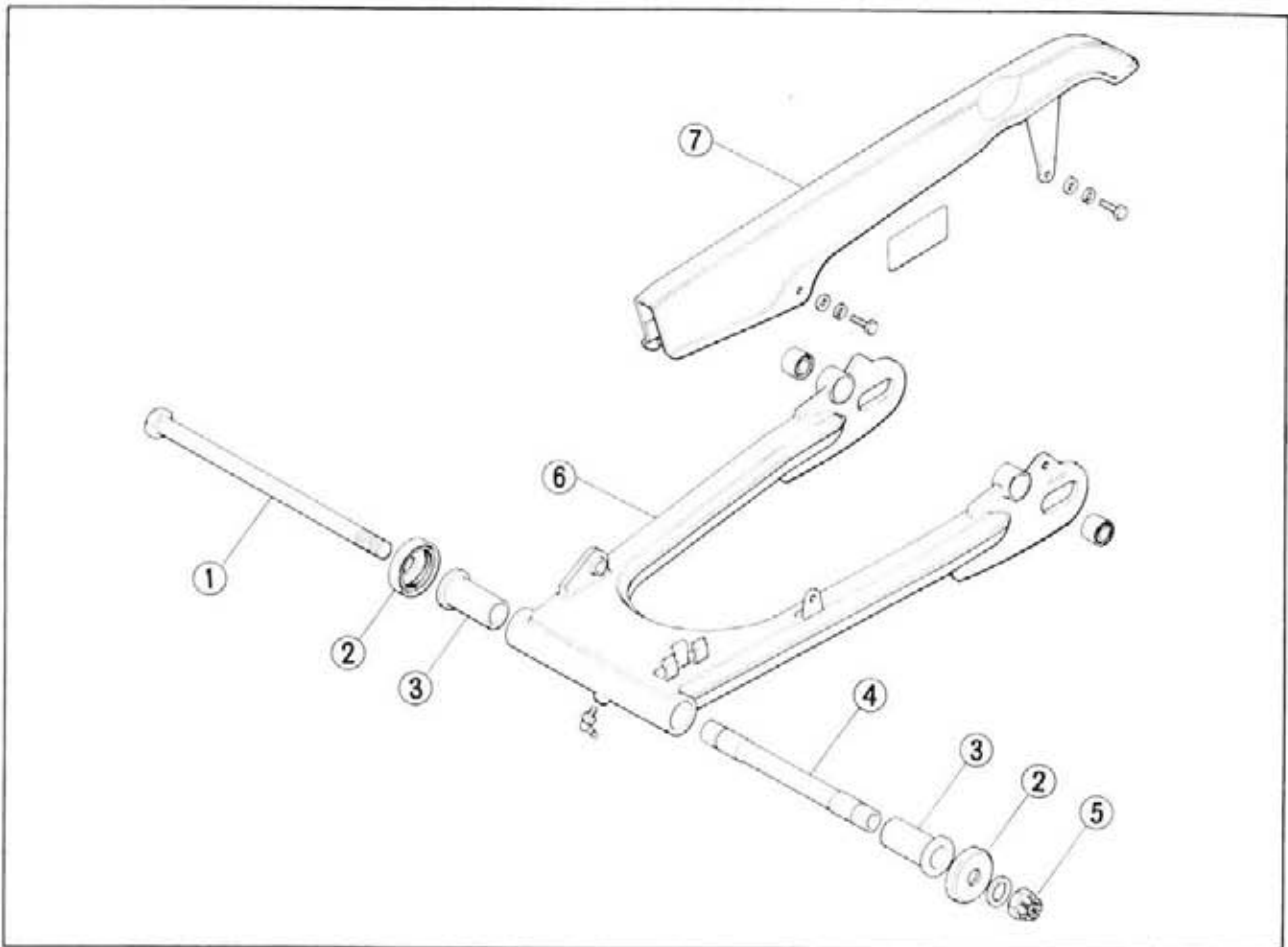


Fig. 12 ① Rear fork pivot bolt ③ Rear fork pivot bushing ⑤ 14 mm self-locking nut ⑦ Chain case
② Dust seal cap ④ Rear fork center collar ⑥ Rear fork

Disassembly

1. Remove the rear shock absorber mounting nut ②.
2. Remove the bolt ④ to remove the rear shock absorber.
3. Remove the torque link from the rear brake.

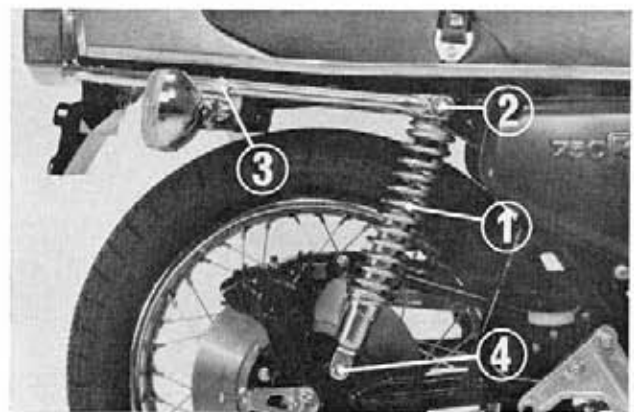


Fig. 13 ① Rear shock absorber
② Rear shock absorber mounting nut

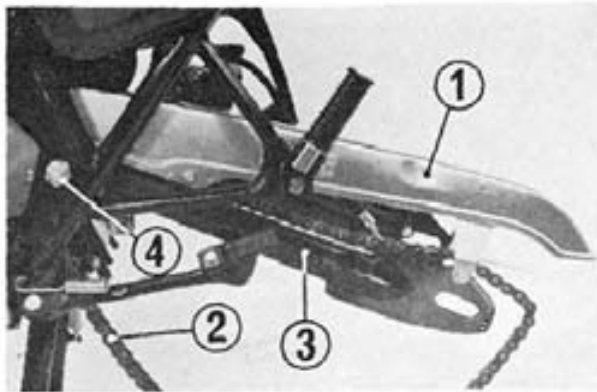


Fig. 14 ① Drive chain case ③ Self-locking nut
② Drive chain



Fig. 15 ① Rear fork pivot bolt

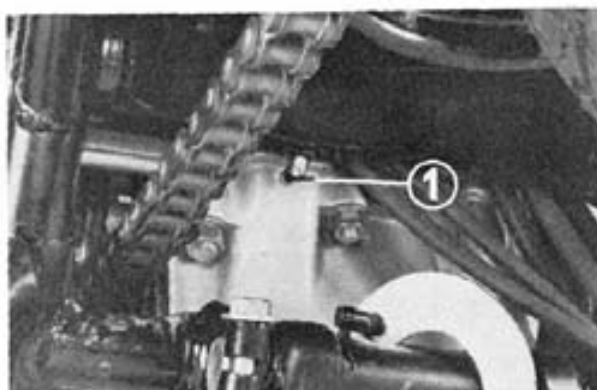


Fig. 16 ① Grease nipple

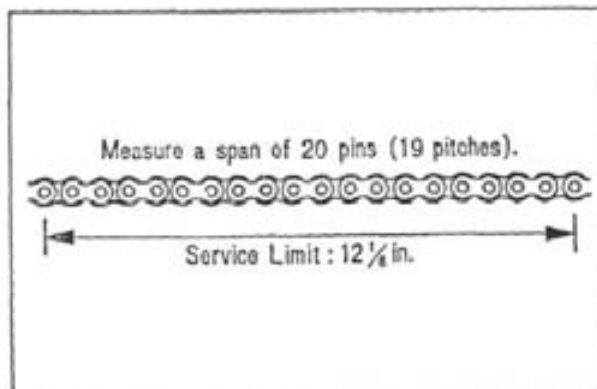


Fig. 17

4. Remove the chain case.
5. Remove the self-locking nut, pull off the rear fork pivot bolt and take the rear fork off the frame.
6. Remove the dust seal cap, pivot bushing and center collar from the rear fork.

Inspection

1. Check the rear fork for deformation, damage or other defects.
2. Check the rear fork center collar and bushing for excessive looseness.
3. Check the pivot shaft for bending along its entire length.
4. Check the axle holes in the rear fork ends for alignment.

Assembly

Assembly is the reverse order of the disassembly.

1. Apply a coating of grease to the rear fork center collar before installing the rear fork to the frame.
2. Coat the sealing lip of the dust seal with grease when assembling the dust seal cap.
3. Insert the rear fork pivot bolt from the right side with the end through the fork; install the self-locking nut on the end and tightening torque.
4. Pump grease through the grease fitting at the rear fork.

Measuring drive chain wears

Measure a section of drive chain to determine whether the chain is worn beyond its service limit. Put the transmission in gear, then turn the rear wheel forward until the lower section of the chain is pulled taut. With the chain held taut and any stiff joints straightened measure the distance between a span of 20 pins, from pin center to pin center. It will measure 11 ⁷/₈ in. (each pitch = ⁵/₈ in.) If the distance exceeds 12 ¹/₈ in. the chain is worn out and must be replaced. After the chain is measured, shift the transmission into neutral again before proceeding with inspection and service.

Engine oil change

Fill the oil tank with approximately 2.6 quarts of premium quality, SE, SEA 10W-40 oil. Start the engine and operate for a few minutes. Stop the engine, refill the tank with approximately 1.1 quarts of oil and check the oil level with the filler cap dipstick.

Fuel tank over flow tube inspection

1. Inspect the fuel tank over flow tube for defects.
2. Squeeze lower end of the over flow tube, and remove any oil or water which may have accumulated.

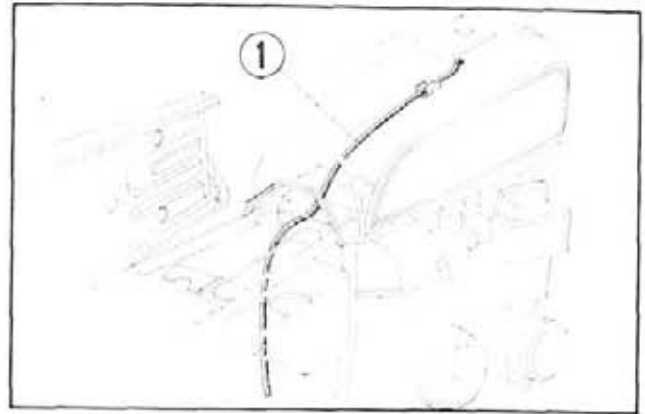


Fig. 18 ① Over flow tube

FRONT SUSPENSION

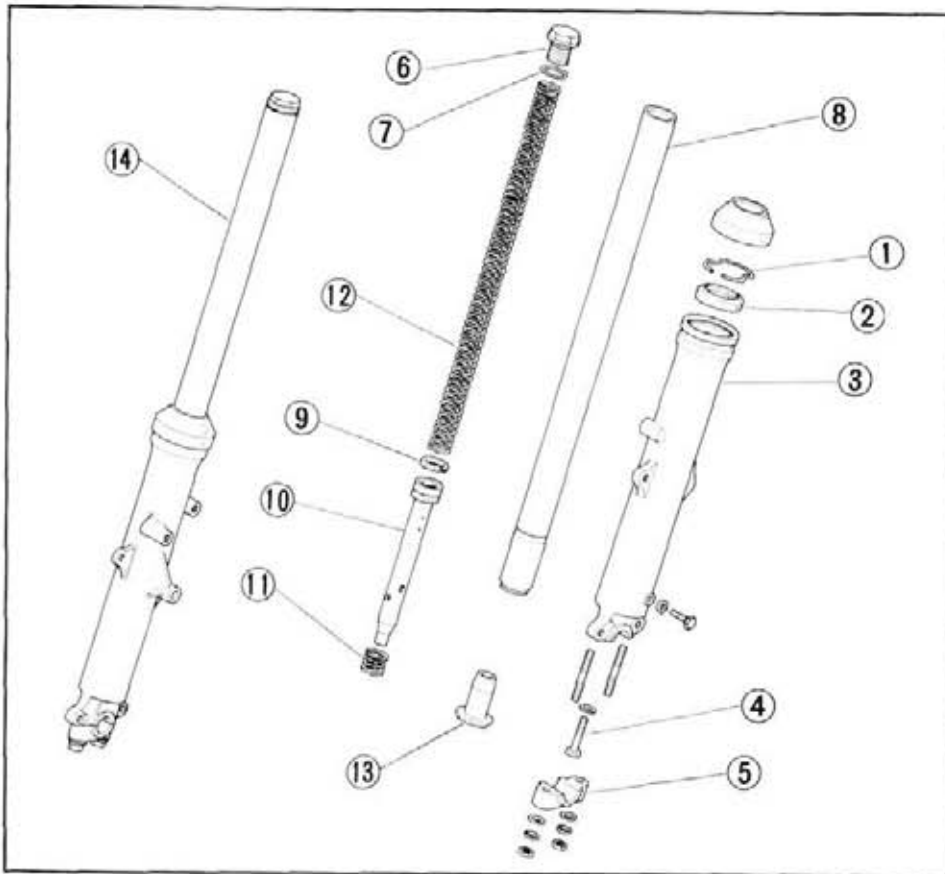


Fig. 19

| | | |
|---------------------|-------------------|---------------------------------|
| ① Oil seal stop | ⑥ Fork bolt | ⑪ Rebound spring |
| ② Oil seal | ⑦ O-ring | ⑫ Front shock absorber spring |
| ③ Bottom case | ⑧ Front fork pipe | ⑬ Oil lock piece |
| ④ Socket bolt | ⑨ Piston ring | ⑭ Front shock absorber assembly |
| ⑤ Front axle holder | ⑩ Bottom pipe | |

REAR SUSPENSION

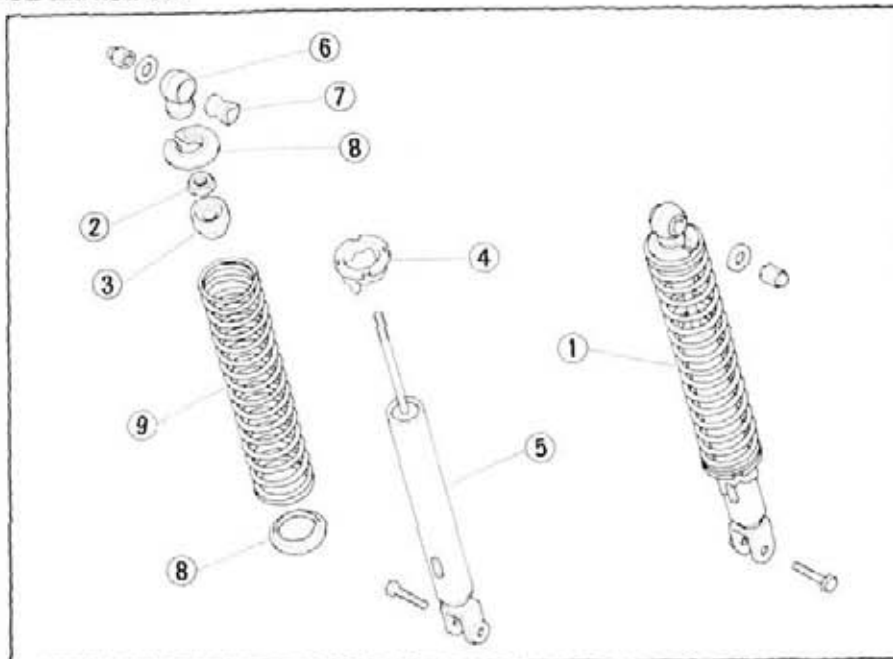


Fig. 20 ① Rear shock absorber assembly ④ Spring adjuster ⑦ Joint rubber
 ② Lock nut (10mm) ⑤ Rear damper ⑧ Spring seat stop
 ③ Stop rubber ⑥ Upper joint ⑨ Rear shock absorber spring

REAR BRAKE

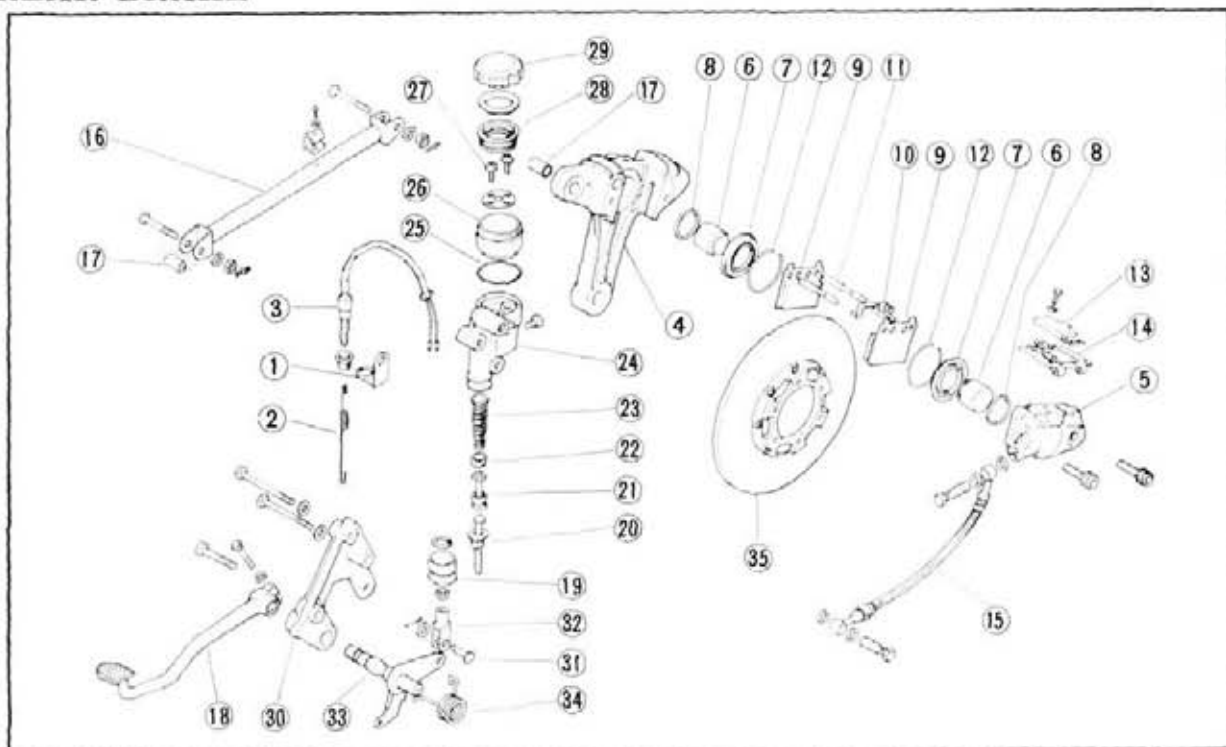


Fig. 21 ① Stop switch bracket ⑩ Spring pad set ⑲ Master cylinder, boot ⑳ Diaphragm
 ② Stop switch spring ⑪ Pad pin ⑳ Push rod ㉑ Oil cup, cap
 ③ Stop light switch ⑫ Dust cover, clip ㉑ Piston ㉒ Rear master cylinder holder
 ④ Caliper A ⑬ Indicator cover ㉒ Primary cup ㉓ Brake rod pin
 ⑤ Caliper B ⑭ Pad cover ㉓ Spring ㉔ Brake rod joint
 ⑥ Piston ⑮ Rear brake hose ㉔ Rear master cylinder ㉕ Brake pedal spring
 ⑦ Dust cover ⑯ Torque link ㉕ O-ring ㉖ Rear brake shaft
 ⑧ Piston seal ⑰ Link collar ㉖ Oil cup ㉗ Brake pedal spring
 ⑨ Pad ⑱ Rear brake pedal ㉗ Oil cup screw ㉘ Rear brake disk

Removal of Caliper

1. Drain the brake system by loosening the caliper bleeder valve.
2. Remove the bolts (3) from the caliper and take out the torque link.

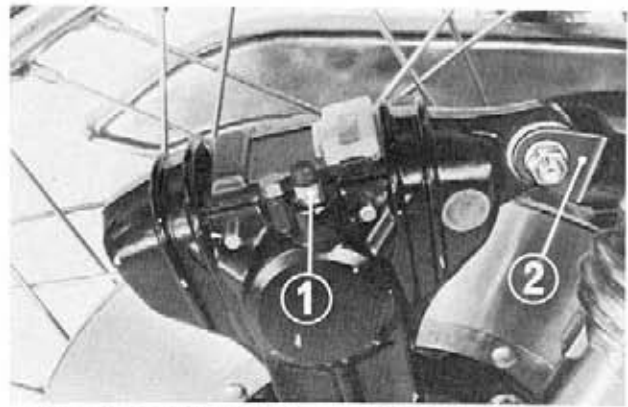


Fig. 22 ① Bleeder valve ② Torque link

3. Pry off the cotter pin, loosen off the axle nut, and remove the axle shaft.

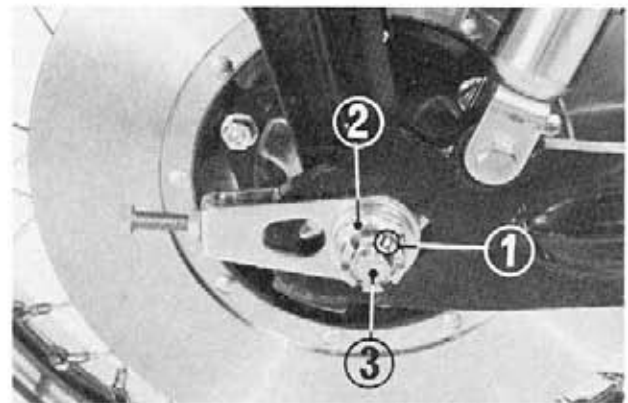


Fig. 23 ① Cotter pin ② Axle nut
③ Axle shaft

4. Remove the oil bolt and pull off the brake hose. Take out the caliper as an assembled unit.

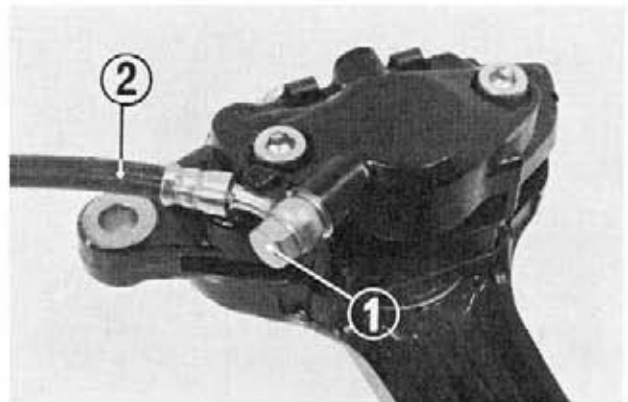


Fig. 24 ① Oil bolt ② Brake hose

Removal of Master Cylinder

1. Remove the rear brake hose off the caliper. Drain the brake system by pumping the brake pedal.
2. Using a suitable pair of pliers, pull off the cotter pin and then remove the brake rod pin.

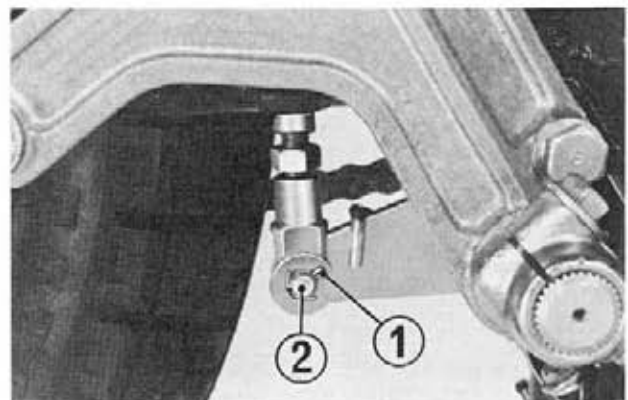


Fig. 25 ① Cotter pin ② Brake rod

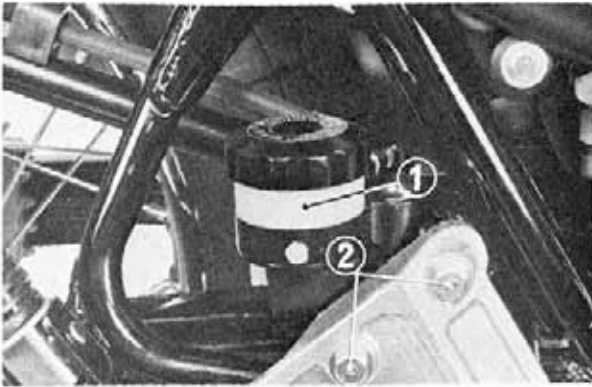


Fig. 26 ① Master cylinder

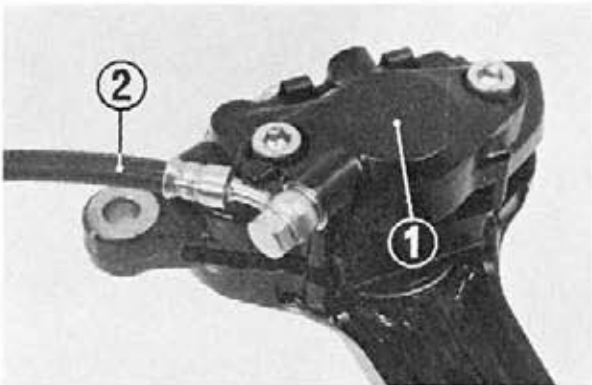


Fig. 27 ① Caliper ② Brake hose

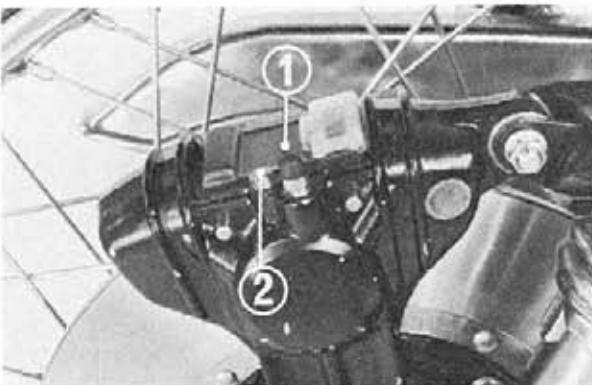


Fig. 28 ① Pad cover ② 5 mm bolt

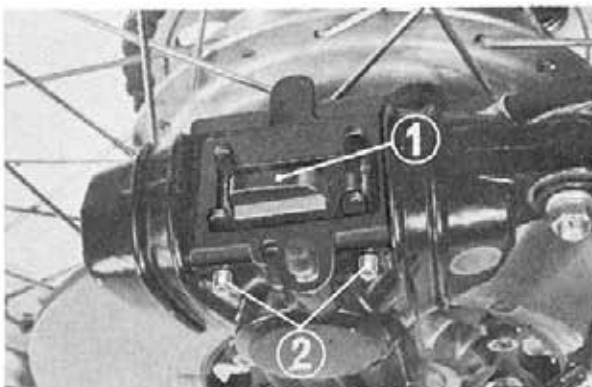


Fig. 29 ① Brake pad set spring
② Brake pad pin

3. The rear brake master cylinder will be taken out easily by removing the bolt ②.

NOTE:

- Handle the master cylinder with care to avoid damaging the brake hose.
- Avoid getting grease on the friction surfaces of the pad and disc since a trace of oil or grease on the friction surface may cause erratic braking performance.
- Do not spill brake oil onto the tire.

Caliper

1. Disconnect the brake pipe from the master cylinder as per the instruction given in preceding paragraph.
2. Remove the caliper off the rear fork following the procedure under Removal of rear fork.
3. Disconnect the brake hose from the caliper.

Replacement of brake pad (rear)

1. Remove the 5mm bolts securing the pad cover to the caliper.
2. Press down on the brake pad set spring; without disturbing the above setup, withdraw the upper pin from the pad.

3. Assembly is the reverse order of the disassembly. The pad pin has a step. Hook the pad set spring over the pin at a point where the diameter is reduced.

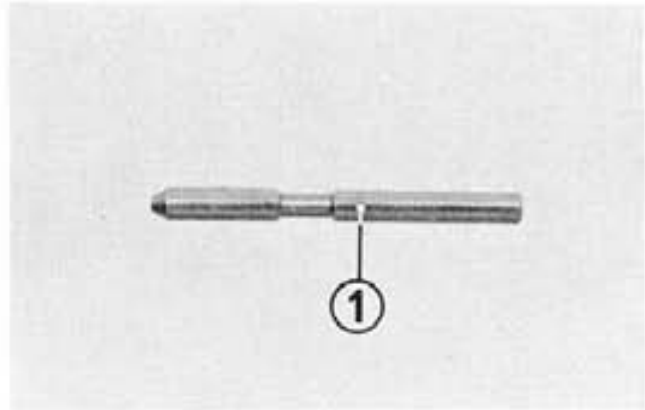


Fig. 30 ① Pad pin

Disassembly

Master cylinder

1. Disconnect the brake rod joint from the push rod by loosening the 8mm nut.
2. Remove the 8mm nut and take out the boot.

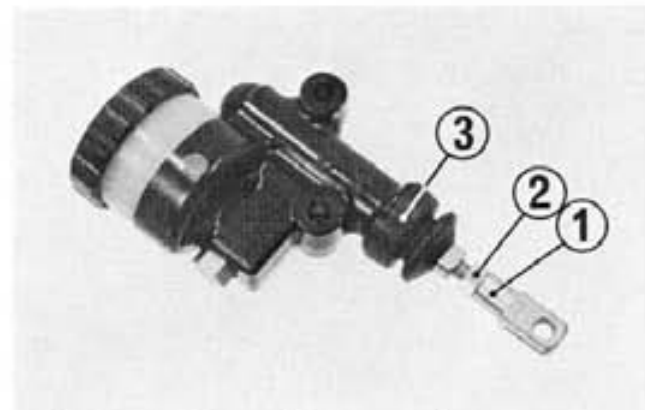


Fig. 31 ① Brake rod joint ② 8mm nut ③ Boot

3. Using tool "Snap Ring Pliers" (Tool No. 07914-3230000), remove the internal snap ring. The push rod can then be taken out.

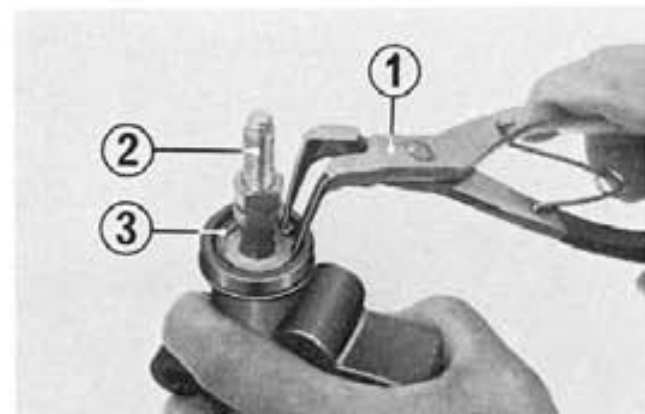


Fig. 32 ① Snap ring pliers ② Push rod ③ Snap ring

4. Remove the piston together with the secondary cup.
5. Remove the primary cup.
6. Remove the spring.
7. Remove the check valve.
8. Remove the oil cup cap diaphragm in the order listed.

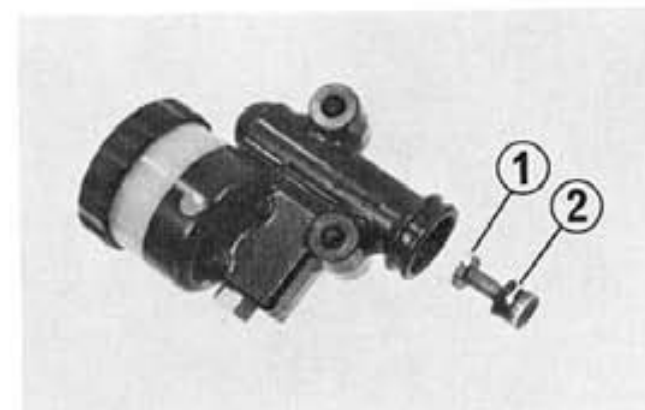


Fig. 33 ① Piston ② Secondary cup

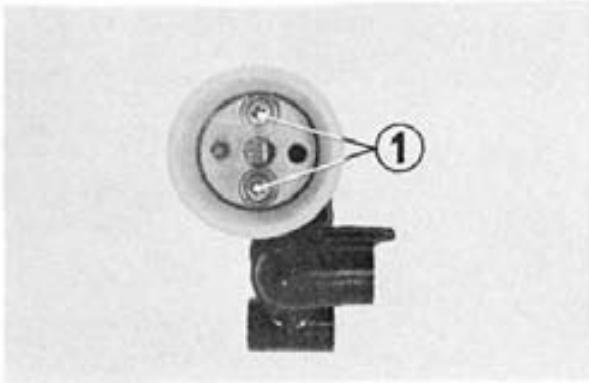


Fig. 34 ① Oil cup screw

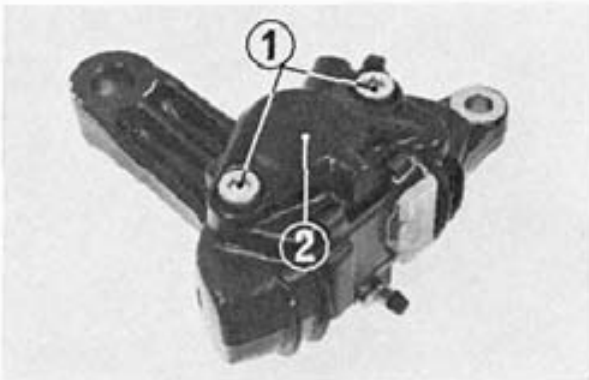


Fig. 35 ① Caliper set bolt ② Caliper B

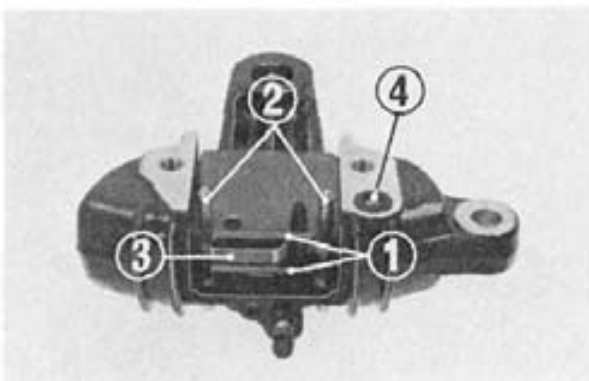
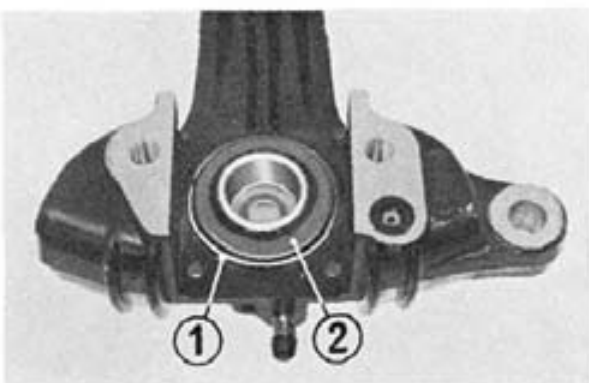
Fig. 36 ① Pad ③ Pad set spring
② Pad pin ④ Joint seal

Fig. 37 ① Dust seal clip ② Dust seal

9. Remove the oil cup screw and take out the oil cup plate.

10. Pull the oil cup off the master cylinder body.

11. Remove the O-ring.

Note: Above steps No. 9 thru. 11 describe the disassembly procedures for separate type master cylinder oil cup (up to Frame No. CB750F-1010686). For machines on and after 1010687, the oil cup is integrated with the master cylinder body.

Caliper

1. Remove the 5mm bolt securing the pad cover to the caliper. The wear indicator cover will then be removed together with the pad cover.

2. With help of a 8mm Allen wrench, unscrew the caliper set bolt. Separate the calipers A and B.

3. Remove the pads, pad pins and pad springs.

4. Remove the joint seal.

5. Remove the dust seal clip to remove the dust seal.

6. Force the piston out of the bore in the caliper by applying compressed air in the oil hole.
7. Take out the piston seal.

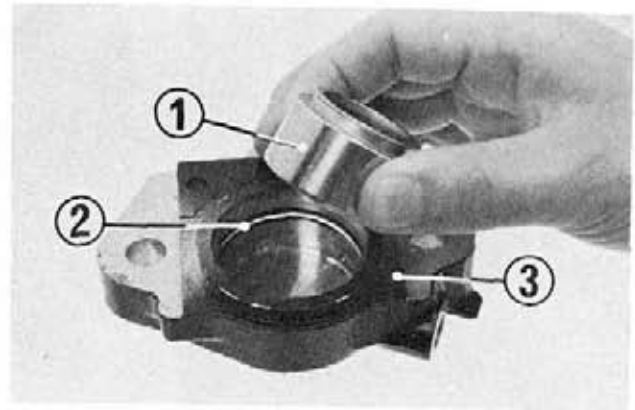


Fig. 38 ① Piston ② Piston seal ③ Caliper B

Inspection

Master Cylinder

1. Measure the ID of the master cylinder to see if it is held within the specified limits. Replace the old cylinder with a new one if it is worn excessively so that the service limit is exceeded. Use a cylinder gauge to measure the cylinder bore.

| | |
|------------------|---------------|
| Standard value | Service limit |
| 14.000~14.043 mm | 14.055 mm |

2. With the use of a micrometer, measure the OD of the piston. If wear is too great, replace with a new one.

| | |
|------------------|---------------|
| Standard value | Service limit |
| 13.957~13.980 mm | 13.940 mm |

3. Check to make sure that the primary and secondary cups are in good condition and are not scored or scratched on their sliding surfaces. Replace the cups with new ones if found to be scored or scratched too badly beyond use.
4. Check the oil for freedom from dust, dirt or any other foreign particles. If necessary, drain oil thoroughly and refill with clean oil up to the correct level.

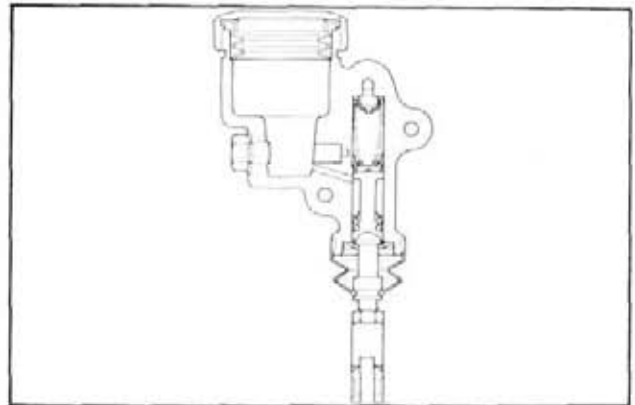


Fig. 39 ① Master cylinder

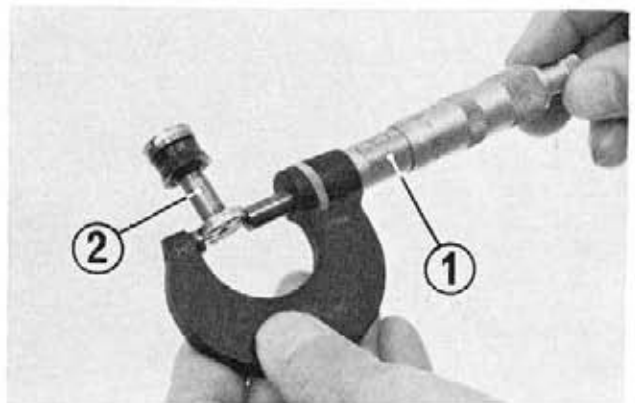


Fig. 40 ① Micrometer ② Piston

Caliper

1. Measure the bore in the caliper using a cylinder gauge. Where wear is too great, replacement is necessary.

| | |
|----------------|---------------|
| Standard value | Service limit |
| 38.18~38.28 mm | 38.245 mm |

2. Measure the OD of the piston with a micrometer. If the service limit is exceeded, the piston should be replaced with a new one.

| | |
|------------------|---------------|
| Standard value | Service limit |
| 3.1115~38.148 mm | 38.105 mm |

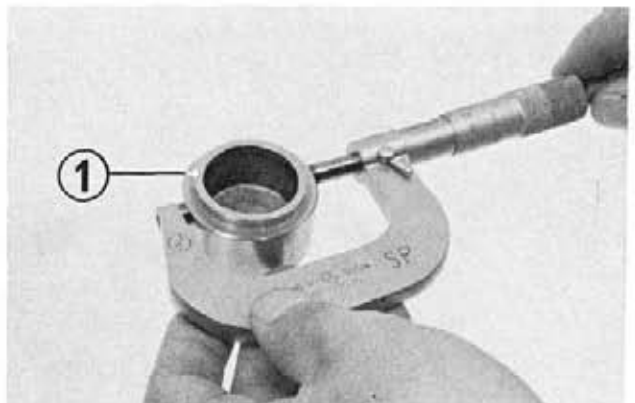


Fig. 41 ① Piston

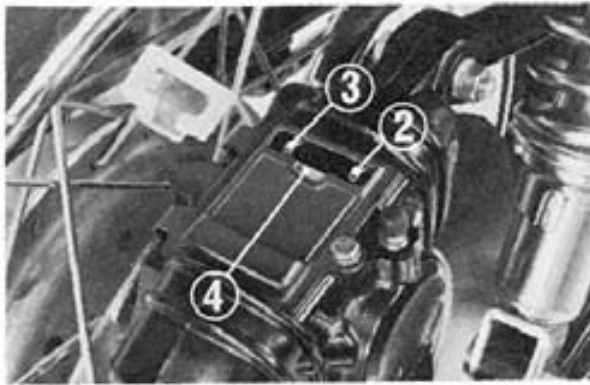


Fig. 42 ① Right brake pad ③ Red mark
② Left brake pad

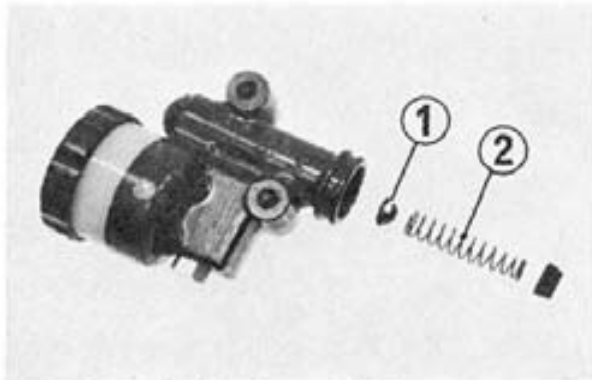


Fig. 43 ① Check valve ② Spring

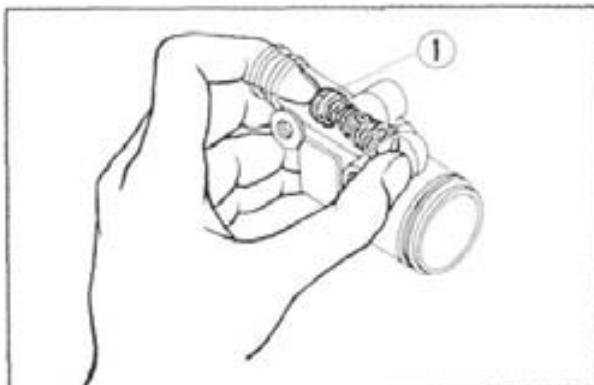


Fig. 44 ① Primary cup

3. Check the piston seal for deterioration or other defects and replace if necessary.
4. Brake pad wear should be checked with the caliper mounted on the frame.
5. Replace both brake pads when the right ② or left ③ pad is worn to the red mark ④ on the caliper.

Brake Hose

1. Check the brake hose for damage, breakage or other defects.
2. Examine if the brake fluid is free from dust, dirt or any other foreign materials. If necessary, drain oil thoroughly and refill with clean oil up to the proper level.

Assembly

Master Cylinder

1. Dip the cylinder, piston and primary and secondary cups in clean brake fluid before they can be assembled.
2. When the check valve is to be installed in the master cylinder, assemble the valve with the valve spring first so that they can be inserted into place in the cylinder easily. Be careful not to install the valve in the reverse direction.
3. Install the primary cup so that the cupped side is toward the spring. Make sure it is square in the bore in the cylinder and is not tilted.
4. After installing the 18 mm internal snap ring, check to make sure that it is seated in the groove properly.

Caliper

1. Check to make sure that the piston seal is seated in the groove in the caliper properly.
2. Apply a thin coating of silicon grease to the inner wall of the cylinder and piston seal.
3. Tighten the caliper set bolt to the following torque:
Specified tightening torque:
250~300 kg-cm

Rear Brake

1. After air has been bled out thoroughly, raise the rear wheel off the ground and make sure that the wheel does not drag by rotating it by hand. Slight dragging can be tolerated here.
2. Before installing the brake pedal, apply grease to the pivot portion.

Brake pedal height adjustment

1. Hold the hex nut ② with a wrench and loosen the lock nut ③.
2. Remove the cotter pin ⑤ and pull out the rear brake pedal pin ⑦.
3. Turning the brake rod ④ in direction ① will decrease the pedal height and turning it in direction ② will increase the pedal height.

Clearance between the brake pedal arm and the footrest should be not less than 0.9 inches (5 mm). After adjusting, secure the brake rod to the pedal with the pedal pin ⑦ plain washer ⑥ and cotter pin ⑤. Always use a new cotter pin and bend the ends of the pin.

Bleeding the Brake System

When the entire system has been overhauled, when the pedal is soft or spongy or when there is any reason to believe that air has been drawn into the system, the system must be bled thoroughly. Also note that the master cylinder does not function if the fluid level is too low, and this will also introduce air into the system and the air bleeding must be carried out.

To bleed air from the brake system, proceed as follows:

1. Fill the master cylinder reservoir with brake fluid. Install the diaphragm to prevent fluid from spilling out of the reservoir.
2. Slip a bleeder pipe on the caliper bleeder valve. Place the lower end of the pipe into a clean glass jar.
3. Depress the brake pedal a full stroke until resistance is felt, and then allow it to return slowly. Repeat this procedure several times, finally holding the pedal fully depressed. Loosen the bleeder valve, and then tighten it immediately after the pedal is depressed to the frame body.
4. Repeat the step 3 several times until the fluid flows from the bleeder pipe without bubbles. Close the bleeder valve.
5. Fill the master cylinder reservoir with brake fluid up to the correct level.

NOTE: Allowing the master cylinder reservoir to empty will cause air to be drawn into the system. During the step 3 above, check the master cylinder frequently to make sure that it contains enough fluid.

6. Bleeder valve tightening torque Specified torque: 70~90 kg-cm

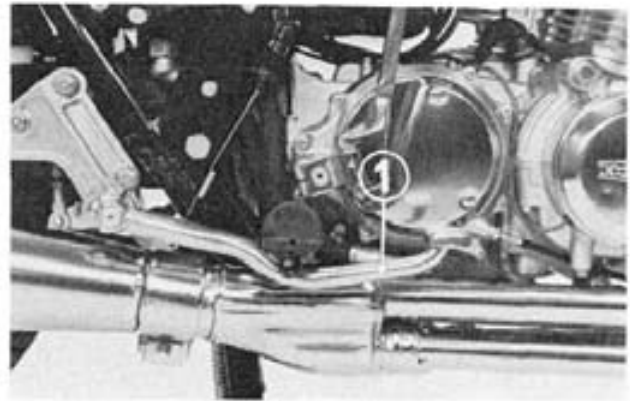


Fig. 45 ① Rear brake pedal

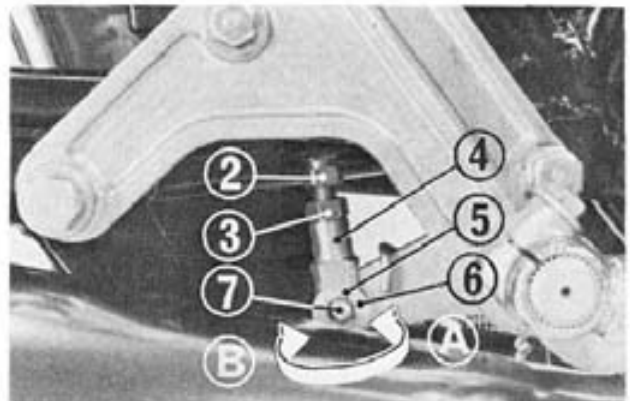


Fig. 46 ② Hex nut ⑤ Cotter pin
③ Lock nut ⑥ Plain washer
④ Brake rod ⑦ Pedal pin



Fig. 47 ① Master cylinder ② Diaphragm

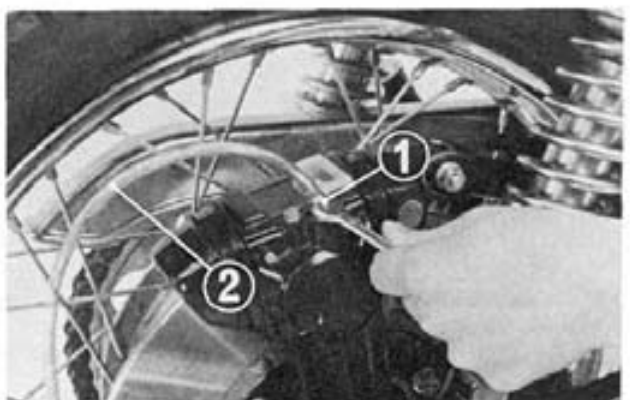


Fig. 48 ① Bleeder valve ② Pipe

REAR WHEEL

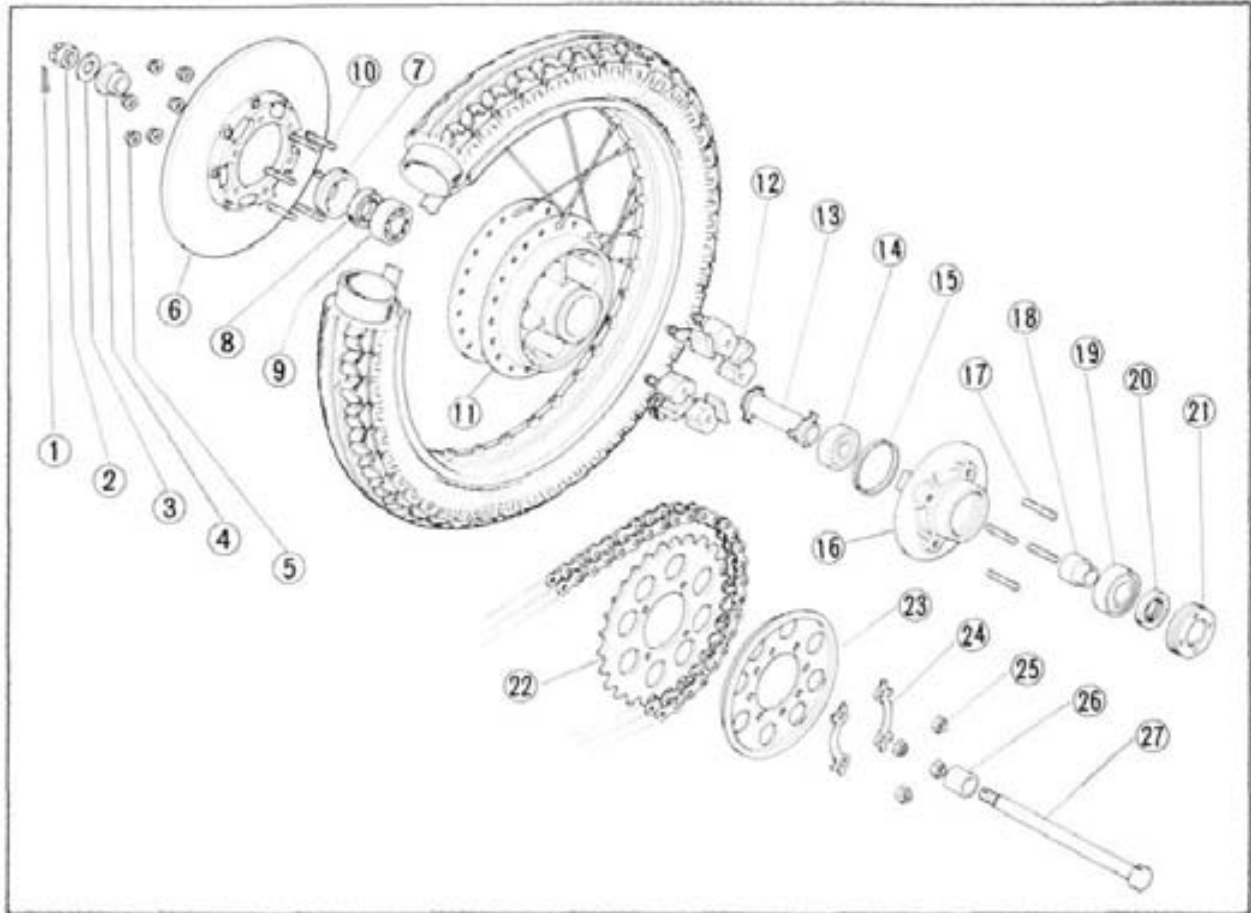


Fig. 49

- | | | | |
|--------------------|---------------------|----------------------|-----------------------|
| ① Cotter pin | ⑧ Oil seal | ⑮ O-ring | Ⓜ Drive sprocket |
| ② Rear axle nut | ⑨ 6304 bearing | ⑯ Final drive flange | Ⓨ Plate sprocket side |
| ③ 18.5×34 washer | ⑩ Stud bolt | ⑰ Stud bolt | Ⓩ Lock washer |
| ④ Side collar | ⑪ Rear wheel hub | ⑱ Axle sleeve | ⓐ Hex Nut |
| ⑤ Disc nut | ⑫ Rear wheel damper | ⑲ 6305 bearing | ⓑ Side collar |
| ⑥ Disc | ⑬ Distance collar | ⑳ Oil seal | ⓓ Rear wheel axle |
| ⑦ Bearing retainer | ⑭ 6304 bearing | ㉑ Bearing retainer | |

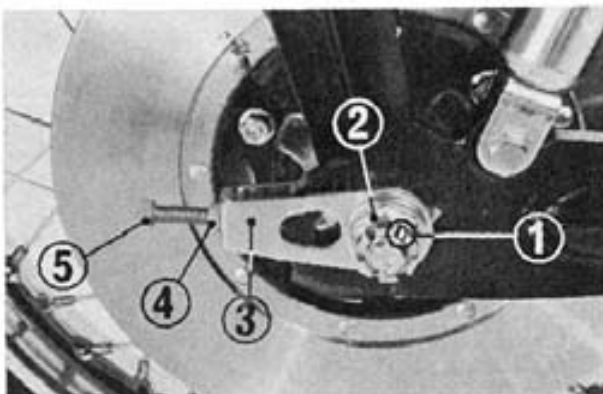


Fig. 50 ① Cotter pin ④ Lock nut
 ② Axle nut ⑤ Chain adjusting bolt
 ③ Drive chain adjuster

Disassembly

1. Loosen the drive chain adjusting bolt and lock nut. Pry the cotter pin off the axle shaft and turn off the axle nut.



2. Remove the drive chain from the final driven sprocket; take out the wheel.
3. Remove the disc nuts and remove the disc from the wheel.

Inspection

1. Wear of disc

Inspect the brake disc for wear. This can be made with a dial gauge and by placing it on a surfaceplate as shown. If the dial gauge reading exceeds the service limit, replace the disc.

| Standard value | Service limit |
|----------------|---------------|
| 0~0.1 mm | 0.3 mm |

2. Surface runout of disc

With the brake disc in place on the wheel, check carefully for runout by placing the axle shaft in V blocks. Replace the disc if the runout is excessive.

| Standard value | Service limit |
|----------------|---------------|
| 0~0.1 mm | 0.3 mm |

3. Thickness of disc

Measure the thickness of the brake disc to make sure that it is held within the specified limits. Discs that are worn excessively beyond the service limit must be replaced.

| Standard value | Service limit |
|----------------|---------------|
| 0.05 mm | 0.3 mm |

4. Wear on rear wheel hub

Visually check the rear wheel hub rubber dampers for excessive wear or deterioration.

5. Surface and axial runouts of rear wheel rim

With the wheel bearing in place, insert the wheel axle shaft. Place the shaft on V blocks, holding the wheel vertical. Measure the rim for runout while rotating it by hand carefully. Replace the rim if found to be damaged excessively beyond use.

| Standard value | Service limit |
|----------------|---------------|
| Surface runout | |
| 0.5 mm max. | 2.0 mm min. |
| Axial runout | |
| 0.5 mm max. | 2.0 mm min. |

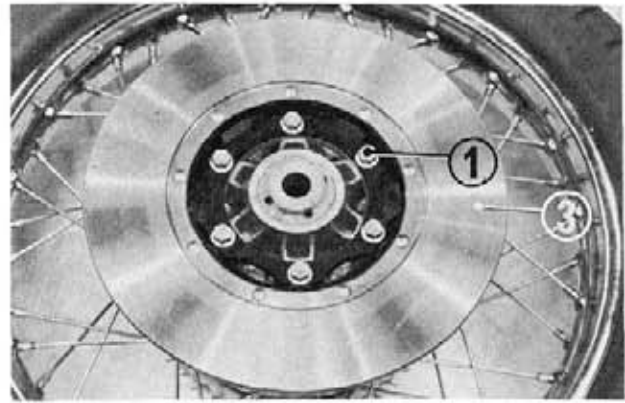


Fig. 51 ① Disc nut
② Disc



Fig. 52 ① Brake disc
② Dial gauge

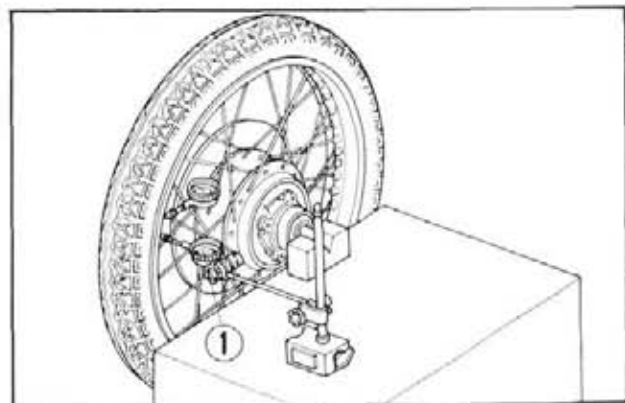


Fig. 53

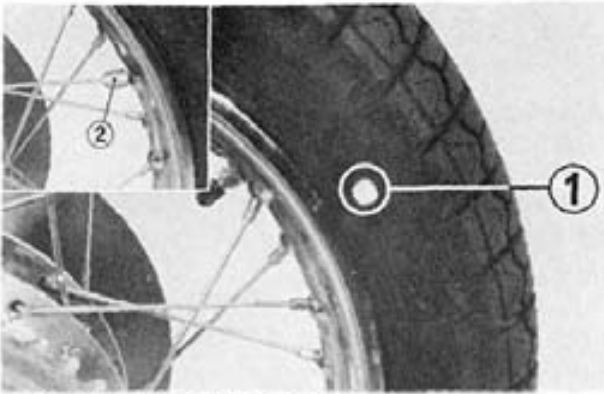


Fig. 54 ① Balancing mark
② Balancing weight

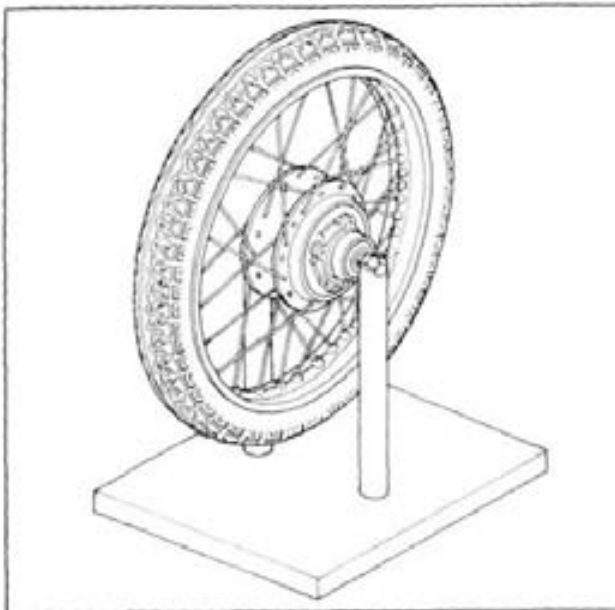


Fig. 55

6. Balancing the Rear Wheel

- a. Remove the rear wheel.
- b. Remove the side collars from both sides of the wheel.
- c. Remove the rear brake disc.
- d. Insert the axle shaft through the rear wheel and place the shaft V blocks, holding the wheel vertical.
- e. Make three chalk marks on the wheel and spin by hand, allowing the heavy part to roll to the bottom.
- f. Attach compensating weights to the top section, and again spin the wheel to check the result.
- g. The weights should be installed to the spoke. The following four weights are available: 5 g, 10 g, 15 g and 20 g.

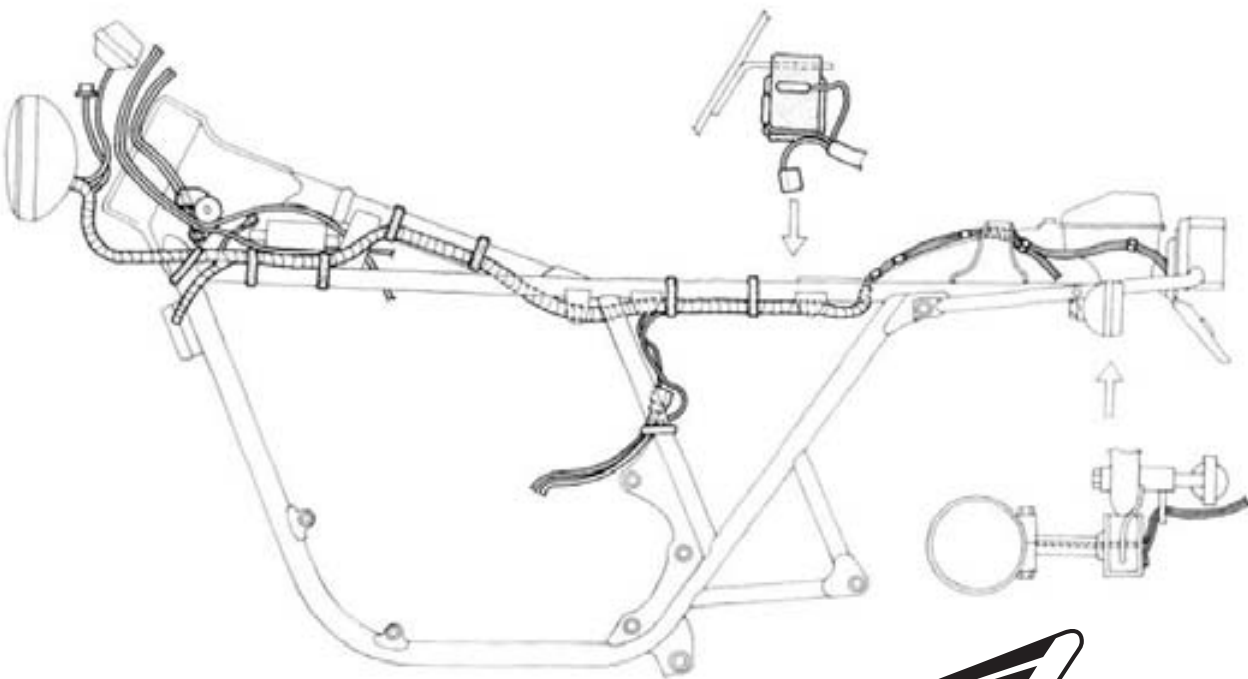
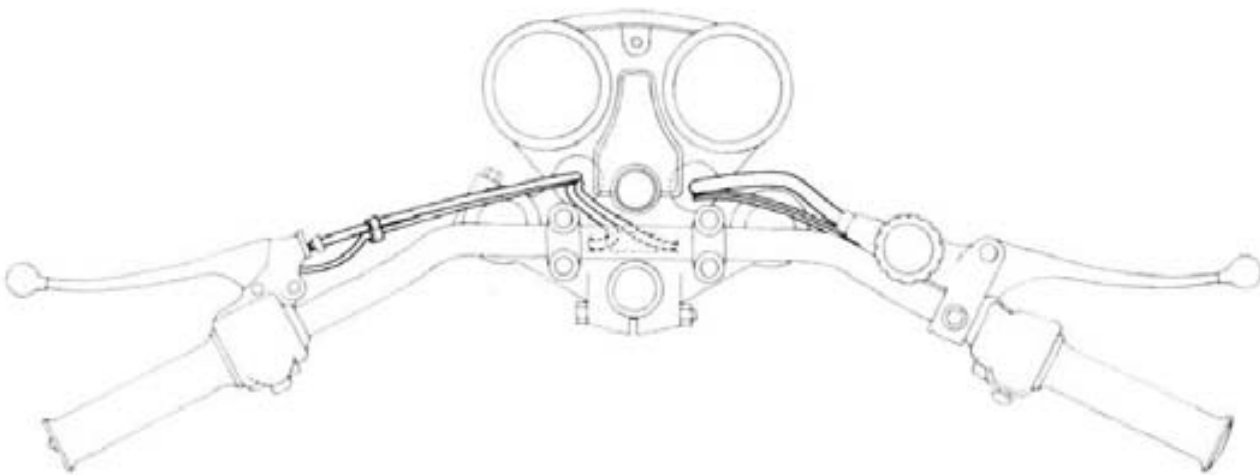
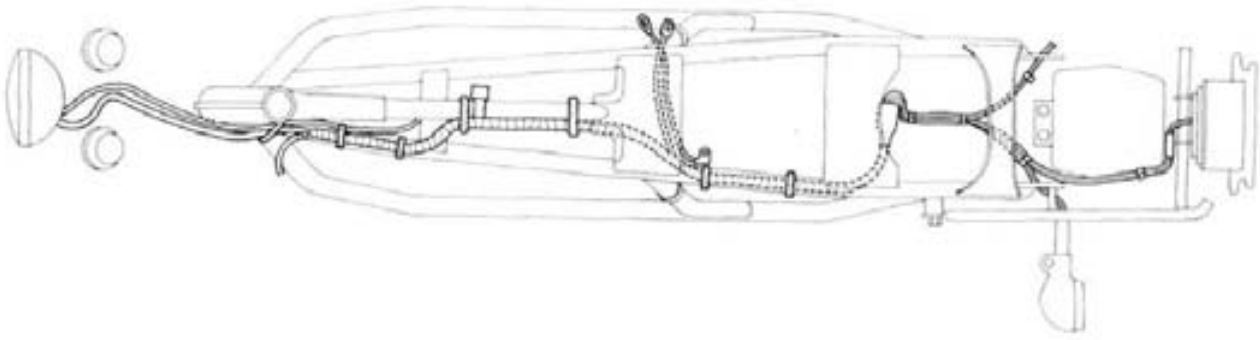
Assembly

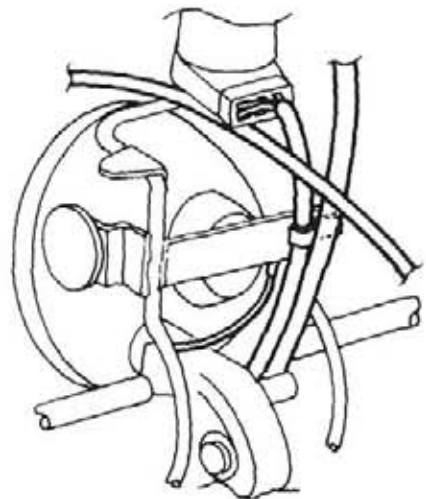
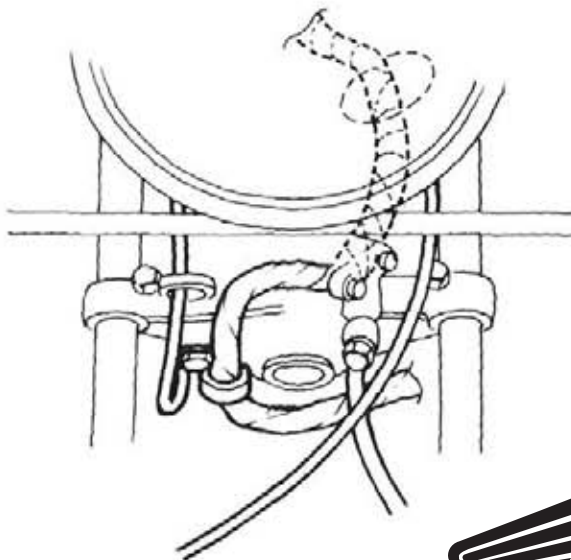
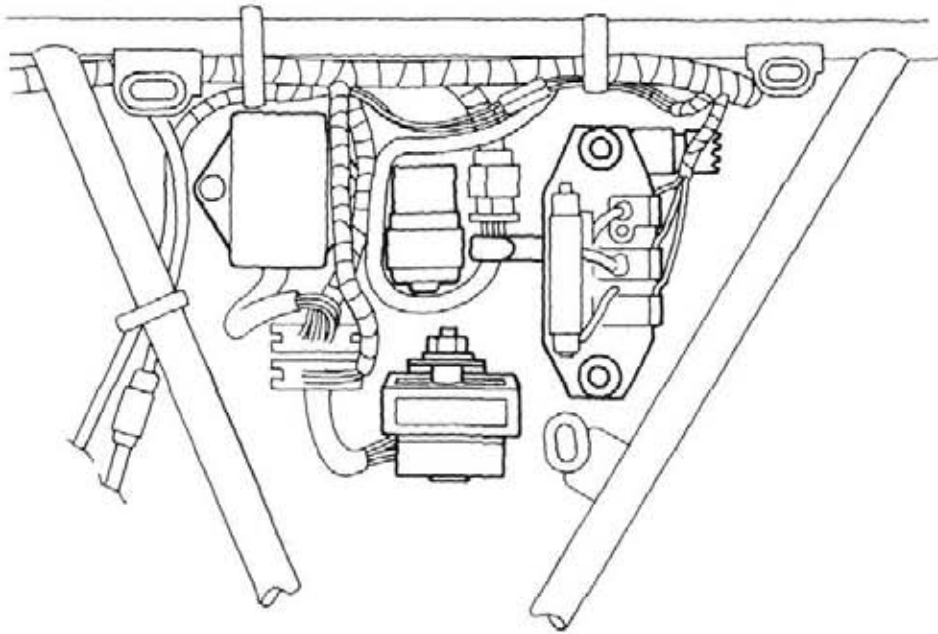
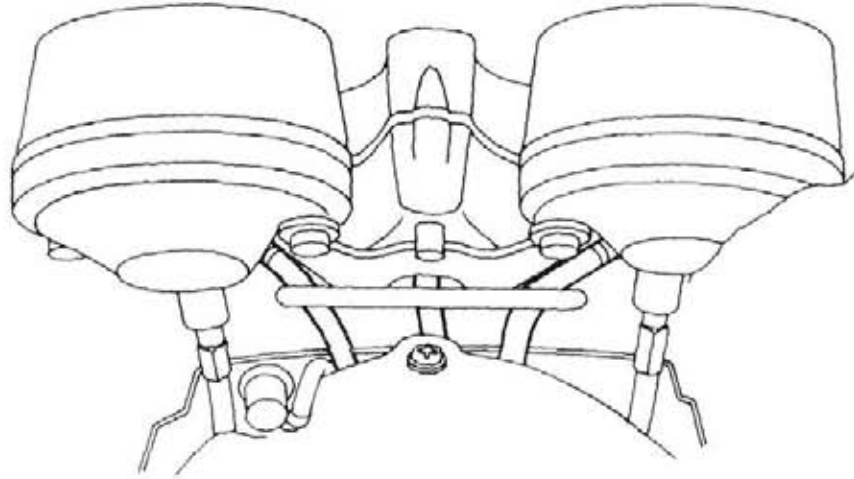
1. Assembly is the reverse order of the removal.

NOTE: Make sure your hands and tools are free of dust and abrasives as they may ruin the bearing if allowed in side.

2. Install the wheel axle shaft from the left side.
3. After assembling, check the tension of the drive chain and the operation of the brake and adjust as necessary.

WIRING





TIGHTENING TORQUE STANDARD

| No. | Tightening point | Torque values | |
|-----|-------------------------------|---------------|-------------|
| | | kg-m | lbs-ft |
| 1 | Tappet adjusting nut | 1.5 ~ 1.8 | 10.8 ~ 13.0 |
| 2 | Cam sprocket knock bolt, 7×12 | 1.6 ~ 2.0 | 11.6 ~ 14.5 |
| 3 | Cylinder head nut, 8 mm | 2.0 ~ 2.5 | 14.5 ~ 18.1 |
| 4 | A.C. generator rotor set bolt | 8.0 ~ 9.0 | 57.9 ~ 65.2 |
| 5 | Starting clutch screw 6×18 | 2.0 ~ 2.5 | 14.5 ~ 18.1 |
| 6 | Connecting rod nut | 1.8 ~ 2.2 | 10.8 ~ 15.9 |
| 7 | Oil pressure switch | 1.4 ~ 1.8 | 10.1 ~ 10.8 |
| 8 | Oil filter center bolt | 2.8 ~ 3.2 | 16.6 ~ 23.1 |
| 9 | Spark plug | 1.2 ~ 1.6 | 8.6 ~ 11.6 |
| 10 | Oil drain bolt | 3.5 ~ 4.0 | 25.3 ~ 28.9 |
| 11 | Tappet hole cap | 1.0 ~ 1.4 | 7.2 ~ 10.1 |
| 12 | Oil path cap | 1.0 ~ 1.4 | 7.2 ~ 10.2 |
| 13 | Drive sproket | 1.1 ~ 1.5 | 5.1 ~ 10.8 |

| No. | Tightening point | Torque values | |
|-----|-----------------------|---------------|-------------|
| | | kg-m | lbs-ft |
| 1 | Foot peg nut | 4.5 ~ 5.5 | 32.5 ~ 39.8 |
| 2 | Rear fork pivot nut | 5.5 ~ 7.0 | 32.5 ~ 50.6 |
| 3 | Oil bolt | 3.0 ~ 4.0 | 21.7 ~ 28.9 |
| 4 | Front fork bolt | 4.5 ~ 5.5 | 32.5 ~ 39.8 |
| 5 | Steering stem nut | 8.0 ~ 12.0 | 57.9 ~ 86.8 |
| 6 | Rear wheel axle nut | 8.0 ~ 10.0 | 57.8 ~ 72.3 |
| 7 | Front wheel axle nut | 5.5 ~ 6.5 | 39.8 ~ 47.0 |
| 8 | Final driven sprocket | 4.5 ~ 5.5 | 32.5 ~ 39.8 |
| 9 | Front stop switch | 3.0 ~ 4.0 | 21.7 ~ 28.9 |

Standard parts

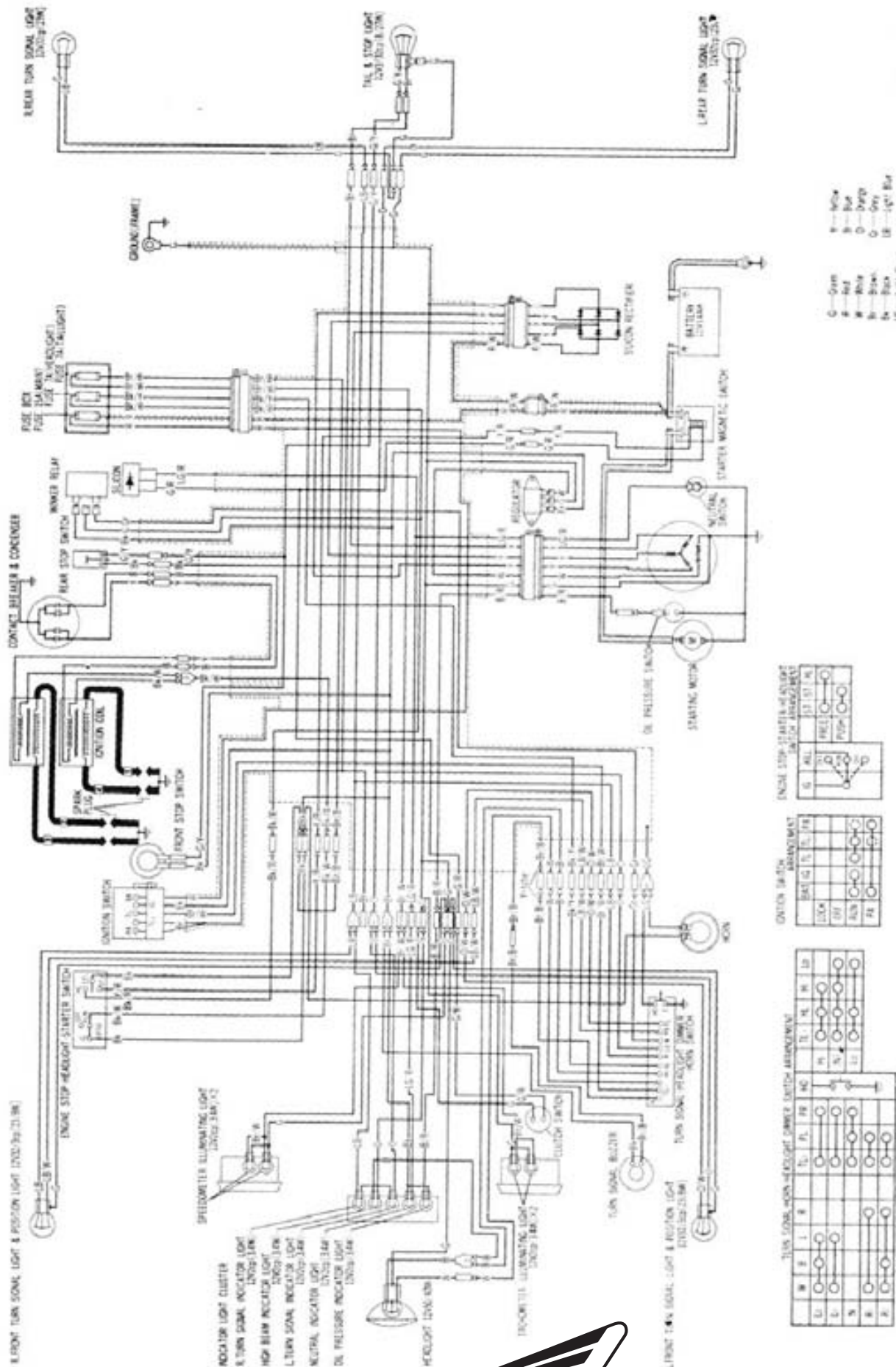
| | Torque values | | | Torque values | |
|------------------------|---------------|-----------|-------------------------|---------------|-----------|
| | kg-m | lbs-ft | | kg-m | lbs-ft |
| SCREW pan 5 mm | 0.35~ 0.5 | 2.5~ 3.6 | BOLT hex. NUT hex 10 mm | 3.0~ 4.0 | 21.7~28.9 |
| SCREW pan 6 mm | 0.7 ~ 1.1 | 5.1~ 8.0 | BOLT hex. NUT hex 12 mm | 5.0~ 6.0 | 36.2~43.4 |
| BOLT hex. NUT hex 5 mm | 0.45~ 0.6 | 3.2~ 4.4 | BOLT flange 6 mm | 1.0~ 1.4 | 7.2~10.1 |
| BOLT hex. NUT hex 6 mm | 0.8 ~ 1.2 | 5.8~ 8.7 | BOLT flange 8 mm | 2.4~ 3.0 | 17.2~21.7 |
| BOLT hex. NUT hex 8 mm | 1.8 ~ 2.5 | 10.1~18.1 | BOLT flange 10 mm | 3.0~ 4.0 | 21.7~28.9 |

SPECIFICATIONS CB 750 F

| | Item | Metric | English | |
|-----------|------------------------------------|---|------------------------------------|--|
| Dimension | Overall length | 2,200 mm | 86.6 in | |
| | Overall width | 860 mm | 33.9 in | |
| | Overall height | 1,160 mm | 45.7 in | |
| | Wheel base | 1,470 mm | 57.9 in | |
| | Seat height | 810 mm | 31.9 in | |
| | Foot peg height | 320 mm | 12.6 in | |
| | Ground clearance | 135 mm | 5.3 in | |
| | Dry weight | 227 kg | 499 lb | |
| Frame | Type | Double crable | | |
| | F. suspension, travel | Telescopic fork, travel 141.5 mm 5.6 in | | |
| | R. suspension, travel | Swing arm , travel 86.3 mm 4.0 in | | |
| | F. tire size, pressure | 3.25 H-19-4PR Rib pattern, tire air pressure 2.25 kg/cm ² 32 psi | | |
| | R. tire size, pressure | 4.00 H-18-4PR Block pattern, tire air pressure 2.80 kg/cm ² 40 psi | | |
| | F. brake, lining area | Disk Brake, lining swept area 685.2 cm ² 106.2 sq. in | | |
| | R. brake, lining area | Disk Brake, lining swept area 672.3 cm ² 104.2 sq. in | | |
| | Fuel capacity | 18 lit | 4.3 U.S. gal 4.0 Imp. gal | |
| | Fuel reserve capacity | 5 lit | 1.3 U.S. gal 1.1 Imp. gal | |
| | Caster angle | 62° | | |
| | Trail length | 115 mm | 4.5 in | |
| | Front fork oil capacity | 145~155 cc | --- | |
| Engine | Type | Air cooled 4 stroke OHC engine | | |
| | Cylinder arrangement | 4 cylinder in line | | |
| | Bore and stroke | 61.0×63.0 mm | 2.402×2.480 in | |
| | Displacement | 736 cc | 44.91 cu. in | |
| | Compression ratio | 9.2 : 1 | | |
| | Valve train | Chain driven valve type venturi dia 28 mm | | |
| | Oil capacity | 3.5 lit | 3.7 U.S. qt 3.1 Imp. qt | |
| | Lubrication system | Forced pressure and dry sump | | |
| | Cylinder head compression pressure | 12 kg/cm ² (170.7 psi) | | |
| | Intake valve | Open | At 5° (before top dead center) | |
| | | Close | At 35° (after bottom dead center) | |
| | Exhaust valve | Open | At 35° (before bottom dead center) | |
| | | Close | At 5° (after top dead center) | |
| | Valve tappet clearance | IN: 0.05 Ex: 0.08 mm | IN: 0.002 Ex: 0.003 in | |
| | Idle speed | 1000 rpm | | |

| | Item | Metric | English | |
|-------------|-----------------------------|---|----------|------------|
| Carburetor | Type | Piston valve | | |
| | Setting mark | 064 A | | |
| | Main jet | ϕ 105 | | |
| | Slow jet | ϕ 40 | | |
| | Air screw opening | 1 ± 3/8 turns | | |
| | Float height | 26 mm | 0.866 in | |
| Drive train | Clutch | Wet mulit plate type | | |
| | Transmission | 5 speed constant mesh | | |
| | Primary reduction | 1.985 | | |
| | Gear ratio I | 2.500 | | |
| | Gear ratio II | 1.708 | | |
| | Gear ratio III | 1.333 | | |
| | Gear ratio VI | 1.133 | | |
| | Gear ratio V | 0.969 | | |
| | Final reduction | 2.824, drive sprocket 17 T, driven sprocket 48 T | | |
| | Gear shift pattern | left foot operated return system | | |
| Electrical | Ignition | Battery and Ignition coil | | |
| | Starting system | starter motor or kick starter | | |
| | Alternator | Three phase A.C. generator 12 V 0.21 kW 5,000 rpm | | |
| | Battery capacity | 12 V - 14 AH | | |
| | Spark plug | NGK D8ES-L | ND X24ES | |
| | Headlight | Low/High | 12 V | 40/50 watt |
| | Tail/stoplight | Tail/stop | 12 V | 3/32 CP |
| | Turn signal-light | Front/Rere | 12 V | 32/32 Cp |
| | Speedometer light | | 12 V | 2 CP |
| | Techometer light | | 12 V | 2 CP |
| | Neutral indicator light | | 22 V | 2 CP |
| | Turn signal indicator light | | 12 V | 2 CP |
| | High beam indicator | | 12 V | 2 CP |
| | Position Light | | 12 V | 3 Cp |

WIRING DIAGRAM CB750F



00180-790-4009

1. LUBRICATION SYSTEM

The drive chain lubricating mechanism, page 189, was discontinued. Concurrent with this change, the final drive system will incorporate a new, modified driven shaft as shown.

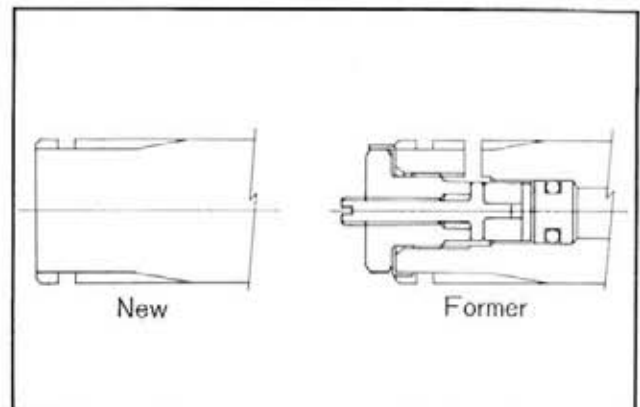


Fig. K6-1 Final driven shaft

2. CLUTCH

Effective with the subject machine serial number, all CB750 will include a 40mm snap ring to retain the clutch outer on the primary driven sprocket.

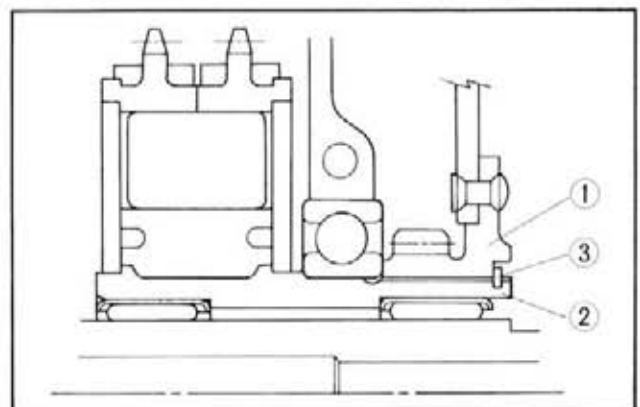


Fig. K6-2 ① Clutch outer ③ 40mm snap ring
② Primary driven sprocket

3. CARBURETOR

The carburetor will be a continuation from the previous type with the exception that the throttle stop screw is relocated from the left to the right side. Specifications of the revised carburetor are as shown immediately below:

| | |
|-------------------|-------------------|
| Setting No. | 086A |
| Main jet | №105 |
| Slow jet | №40 |
| Air screw opening | 1 ± 1/8 |
| Float height | 26 mm (1,024 in.) |

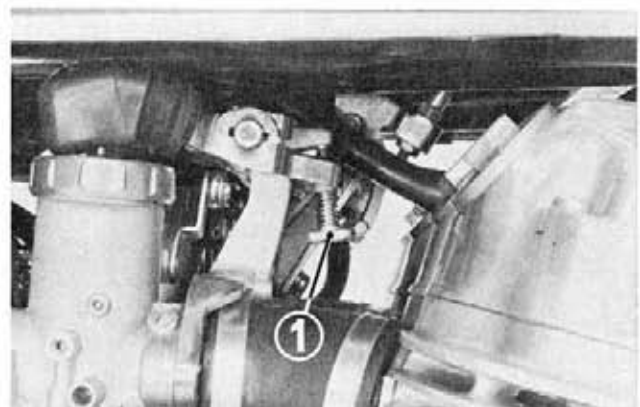


Fig. K6-3 ① Throttle stop screw

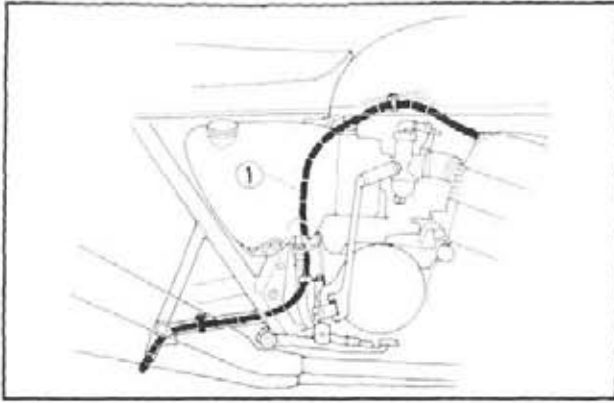


Fig. K6-4 ① Breather tube

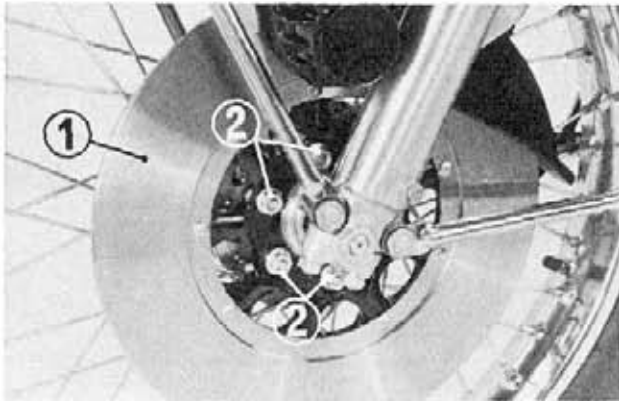
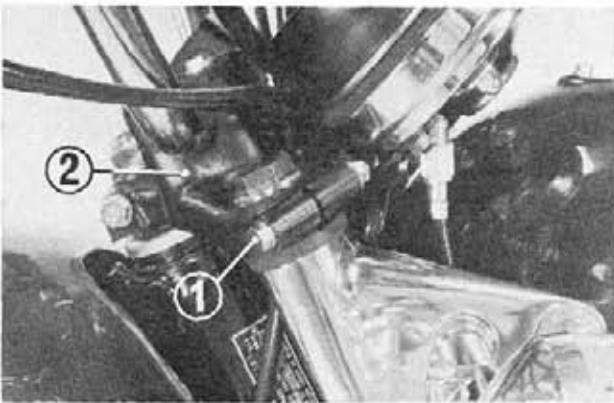
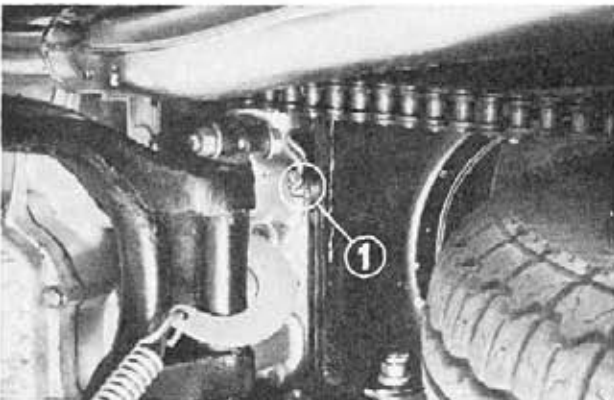
Fig. K6-5 ① Front brake disc
② USB nutFig. K6-6 ① 7mm flange bolt
② Fork top bridge

Fig. K6-7 ① Grease nipple

4. BREATHER TUBE

The breather tube has been rerouted. The tube will extend down along the right rear fork arm as shown. The end of the tube will be kept more than 50mm (2 in.) away from the rear wheel.

5. FRONT WHEEL

The front brake will no longer use the tanged washer and nut arrangement for the attachment of the brake disc to the wheel hub. The disc is now tightened with USB nuts.

Tightening torque: 270-230 kg-cm
(20-24 lbs-ft)

6. FORK TOP BRIDGE

The flanged bolts used for tightening the fork top bridge will be changed in size from 8mm to 7mm.

Tightening torque: 180-250 kg-cm
(13-18 lks-ft)

7. DRIVE CHAIN

CB750 now use a new, improved drive chain in place of the one formerly used. For maintenance service tips, see page 230. Use new Drive Chain Joint Tool Set (Tool No. 07975-3000002) when replacing the drive chain.

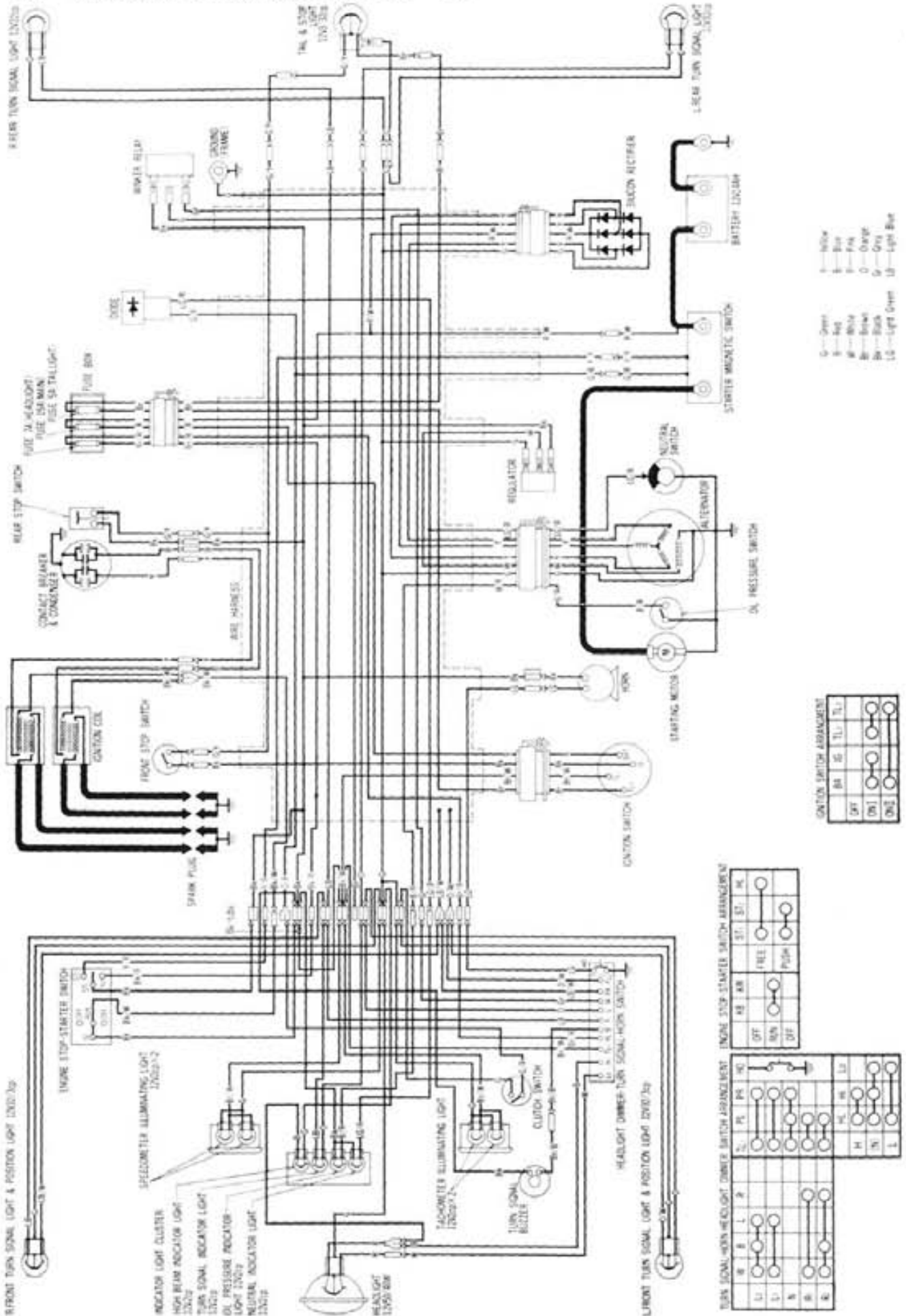
8. REAR FORK

The rear fork pivot pipe now has a grease nipple at its center. The grease nipples formerly located at both ends of the rear fork pivot bolt were discontinued.

9. SPECIFICATIONS (CB750 '76)

| Item | |
|--------------------------|---|
| DIMENSION | |
| Overall Length | 2,175 mm (85.6 in.) |
| Overall Width | 870 mm (34.3 in.) |
| Overall Height | 1,170 mm (46.1 in.) |
| Wheel Base | 1,455 mm (57.3 in.) |
| Seat Height | 810 mm (31.9 in.) |
| Foot Peg Height | 310 mm (12.2 in.) |
| Ground Clearance | 140 mm (5.5 in.) |
| Dry Weight | 218 kg (479 lb.) |
| FRAME | |
| Type | Double Cradle |
| F. Suspension, Travel | Telescopic fork , travel 143 mm (5.6 in.) |
| R. Suspension, Travel | Swing arm , travel 85 mm (3.3 in.) |
| F. Tire Size, Type | 3.25-19-4 PR Rib , tire air pressure 2.0/2.25 kg/cm ² (28/32 psi) |
| R. Tire Size, Type | 4.00-18-4 PR Block , tire air pressure 2.0/2.8 kg/cm ² (28/40 psi) |
| F. Brake | Disk Brake |
| R. Brake | Internal expanding shoe |
| Fuel Capacity | 17 lit. (4.5 U.S. gal. 3.7 Imp. gal.) |
| Fuel Reserve Capacity | 5 lit. (1.3 U.S. gal. 1.1 Imp. gal.) |
| Caster Angle | 63° |
| Trail Length | 95 mm (3.7 in.) |
| Front Fork Oil Capacity | 155~160 cc (5.3-5.4 ozs.) |
| ENGINE | |
| Type | Air cooled 4 stroke O.H.C. engine |
| Cylinder Arrangement | 4 cylinder in line |
| Bore and Stroke | 61.0×63.0 mm (2.402×2.480 in.) |
| Displacement | 736 cc (44.9 cu in.) |
| Compression Ratio | 9.0 : 1 |
| Carburetor, Venturi Dia. | Four piston valve type, venturi dia. 28 mm (1.102 in.) |
| Valve Train | chain driven over head cam shaft |
| Oil Capacity | 3.5 lit. (3.7 U.S. qt 3.1 Imp. qt) |
| Lubrication System | Forced pressure and dry sump |
| Fuel Required | Low-lead gasoline with 91 octane number or higher |
| Air Filtration | Paper filter |
| Valve Tappet Clearance | IN 0.05 EX 0.08 mm (IN: 0.002, EX 0.003 in.) |
| Air Screw Opening | 1 |
| Idle Speed | 950 rpm |
| DRIVE TRAIN | |
| Clutch | wet multi plate type |
| Transmission | 5-speed constant mesh |
| Primary Reduction | 1.708 |
| Gear Ratio I | 2.500 |
| II | 1.708 |
| III | 1.333 |
| IV | 1.097 |
| V | 0.939 |
| Final Reduction | 2.667, drive sprocket 18 T, driven sprocket 48 T |
| Gear Shift Pattern | Left foot operated return system |
| ELECTRICAL | |
| Ignition | Battery and ignition coil |
| Starting System | Starting motor or kick starten |
| Alternator | Three phase AC Generator 0.21 kw/5,000 rpm |
| Battery Capacity | 12 V-14 AH |
| Fuse Capacity | 15 amp. |
| Spark plug | NGK D8ES-L NDX 24ES |

10. WIRING DIAGRAM (CB750 '76)



00003-341-9100

CANTON SWITCH ARRANGEMENT

| | | | | |
|----|----|----|----|----|
| SW | BA | RG | YL | BL |
| ON | ON | ON | ON | ON |

ENGINE STOP/STARTER SWITCH ARRANGEMENT

| | | | | | |
|-----|-----|-----|------|-----|-----|
| OFF | RE | AR | ST | ST | PK |
| ON | ON | ON | FREE | ON | ON |
| OFF | OFF | OFF | PUSH | OFF | OFF |

TURN SIGNAL-HEADLIGHT DIMMER SWITCH ARRANGEMENT

| | | | | | | |
|----|----|----|----|----|----|----|
| W | B | L | P | PL | PK | HC |
| L1 | L1 | N | R | PL | PK | L3 |
| ON | ON | ON | ON | ON | ON | ON |

SUPPLEMENT TO CB750 K7 ('77)

Engine No. CB 750 E—2700001 and
subsequent
Frame No. CB 750—2700002 and
subsequent

GROUP
24

1. CARBURETOR

A. Removal and installation

1. Turn the fuel valve lever to the "OFF" position and disconnect the fuel tube at the fuel valve.
2. Open the seat and remove the fuel tank.
3. Remove the air cleaner lower case by loosening the two mounting bolts. Loosen the air cleaner connecting bands and remove the two air cleaner hanger bolts. Remove the air cleaner upper case from the carburetors.
4. Remove the throttle and choke cables from the cable holder and disconnect them from the shaft levers.
5. Loosen the carburetor insulator bands and take out the carburetor assembly.
6. To install the carburetor assembly, reverse the removal procedure.

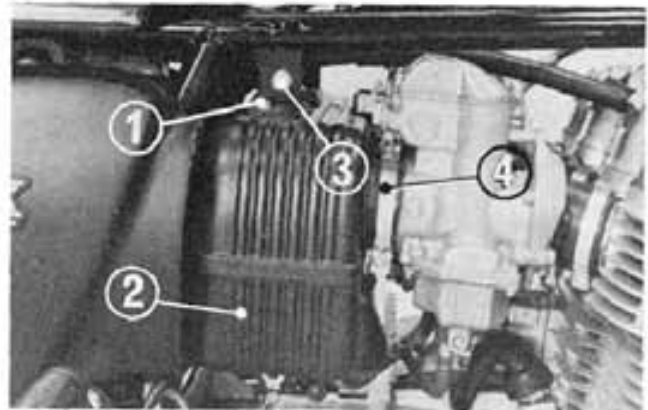


Fig. K7-1 ① Air cleaner mounting bolt
② Lower case
③ Hanger bolt
④ Connecting band

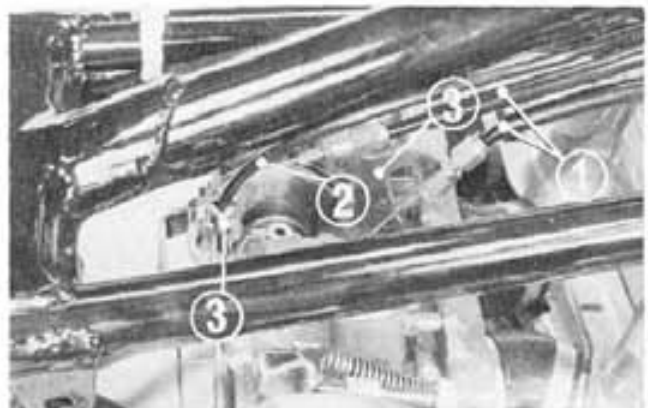


Fig. K7-2 ① Throttle cable
② Choke cable
③ Cable holder

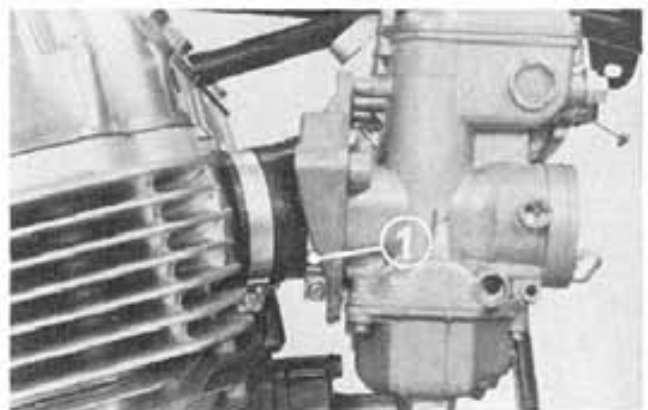


Fig. K7-3 ① Carburetor insulator band

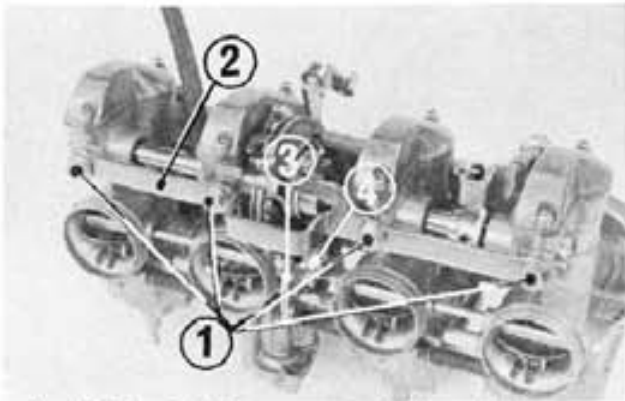


Fig. K7-4 ① Bolt ② Rear stay ③ Choke relief spring ④ Choke lever

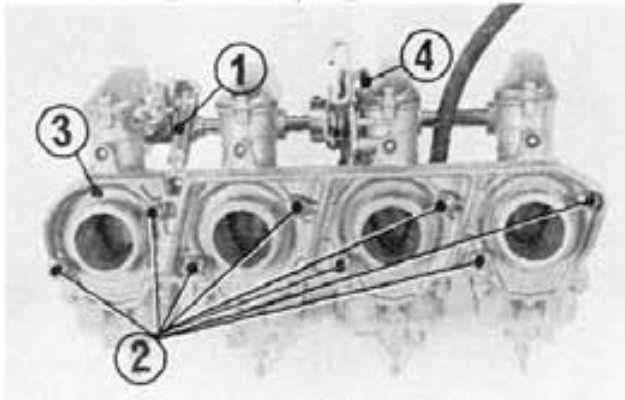


Fig. K7-5 ① Throttle return spring ② Screw ③ Stay plate ④ Accelerator pump spring



Fig. K7-6 ① Link arm fixing screw ② Set screw ③ Lock nut

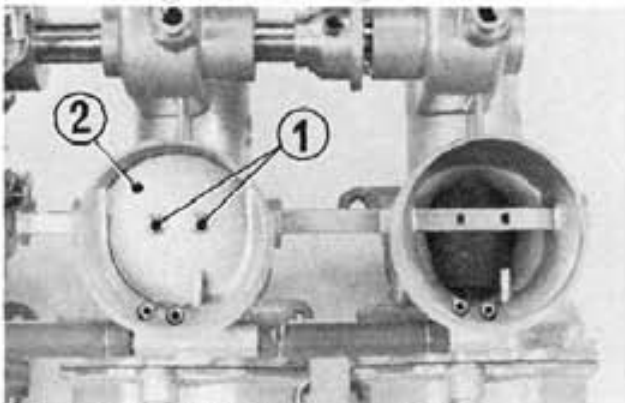


Fig. K7-7 ① Screws ② Choke valve ③ Tube

B. Disassembly

Carburetor, throttle valve and jet needle:

1. Remove the carburetor assembly from the engine.
2. Remove the rear stay from the carburetor assembly by loosening the four bolts.

3. Unhook the throttle return spring from the stopper arm. Remove the stay plate by loosening the eight screws. Remove the accelerator pump spring. Unhook the choke relief spring at the choke lever.

4. Remove the carburetor top by loosening the two screws.
5. Loosen the link arm fixing screw. Loosen the lock nut and remove the throttle lever set screw.

6. Remove the choke valve from the choke shaft by loosening the two screws. Remove the accelerator pump fuel tubes.
7. Separate the carburetors.

8. Remove the link arm assembly from the carburetor.
9. Loosen the two screws and remove the throttle valve and jet needle from the link arm.

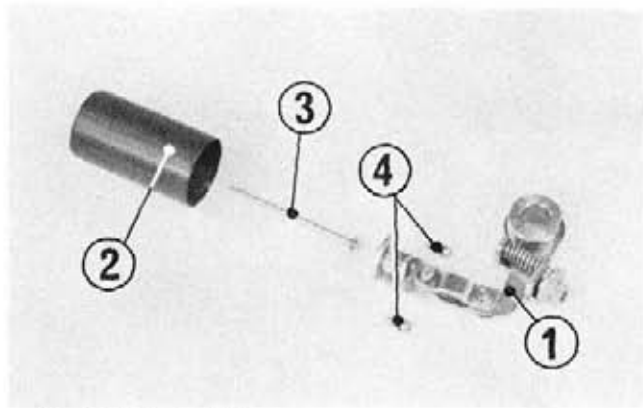


Fig. K7-8 ① Link arm
② Throttle valve
③ Jet needle
④ Screw

Float, main jet, slow jet and accelerator pump:

1. Remove the carburetor assembly from the engine.
2. Remove the float chamber body from the carburetor by loosening the three screws.
3. Pull out the float arm pin and remove the float.
4. Remove the main jet and slow jet.

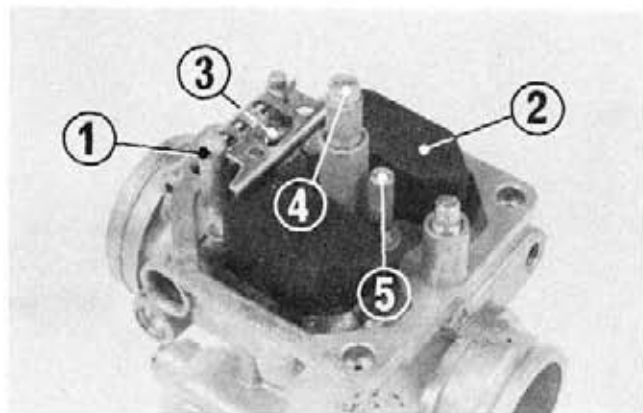


Fig. K7-9 ① Float arm pin
② Float
③ Float valve
④ Main jet
⑤ Slow jet

5. Remove the accelerator pump from the No. 2 carburetor by unscrewing the three screws.

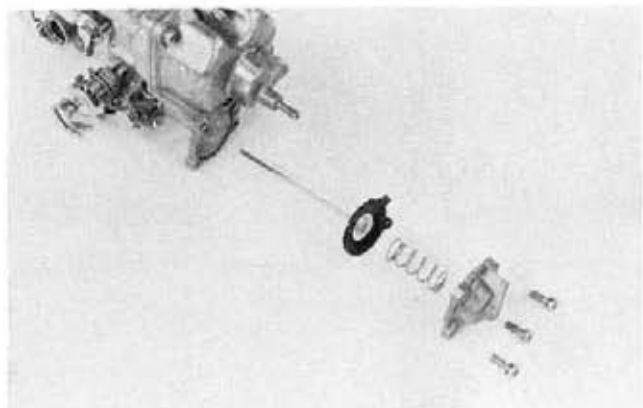


Fig. K7-10 Accelerator pump

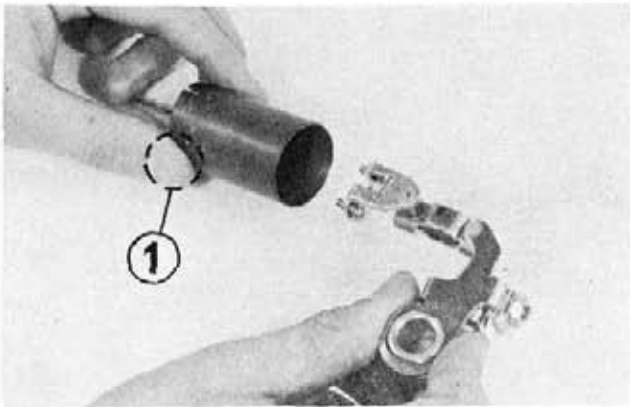


Fig. K7-11 ① Throttle valve cutaway

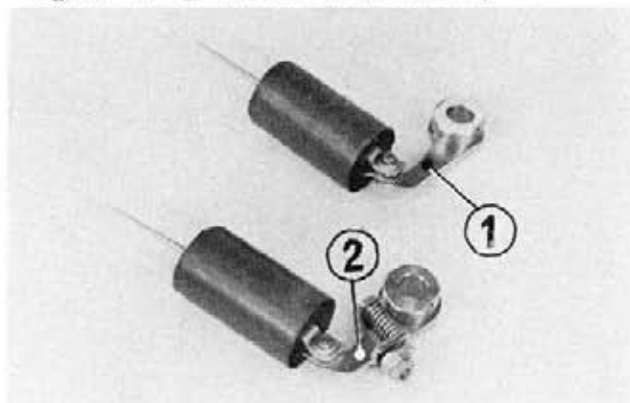
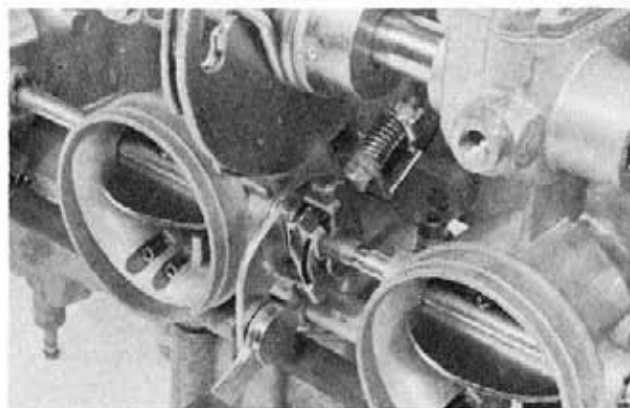
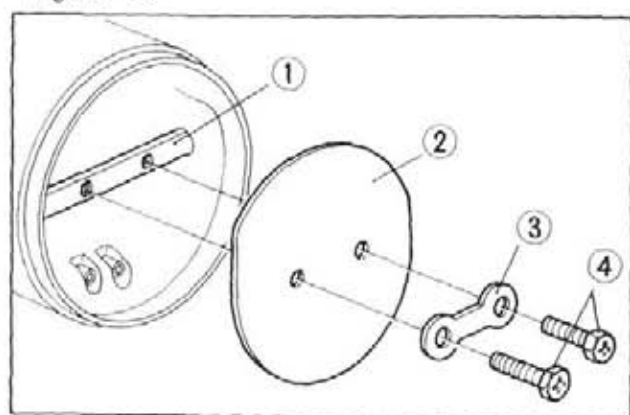
Fig. K7-12 ① Link arm for No. 2 carburetor
② Link arm for No. 1, 3 and 4 carburetor

Fig. K7-13

Fig. K7-14 ① Choke shaft
② Choke valve
③ Lock washer
④ Hex. head screw

C. Assembly

To assemble the carburetor, reverse the disassembly procedure. Observe the following notes:

1. Install the throttle valve to the link arm so that the throttle valve cutaway is toward the choke valve when it is installed in the carburetor body.
2. The link arm which is not equipped with the adjusting screw should be installed in the No. 2 carburetor.
3. Install the choke shaft levers and springs properly as shown in Fig. K7-13.
4. Install the choke valve to the choke shaft by using the lock washer and hex. head screws and bend the lock washer to lock the screws.

NOTE: The choke valve securing screws are peened when assembling the carburetor at the factory. Discard the used screws.

D. Carburetor setting table

| Item | |
|--------------------|---------------------|
| Main jet No. | #115 |
| Air jet No. | #150 |
| Slow jet No. | #35 |
| Slow air jet No. | #150 |
| Jet needle setting | F2D51E-1 |
| Float height | 12.5 mm (0.492 in.) |

E. Adjustment

Idle speed:

Make the adjustment after warming up the engine.

1. Adjust the idle stop screw to allow the engine to run at the idle speed of 950 to 1,050 rpm.
2. Turn the pilot screw either in or out to obtain the highest idle speed. Usually the correct setting will be found to be 1 1/2 turns open from a fully closed position.
3. If idle speed changes after adjusting the pilot screw, readjust the idle stop screw.

Synchronizing carburetors:

1. Remove the fuel tank. Position the fuel tank higher than the carburetors and reconnect with a longer fuel tube.
2. Connect the vacuum gauge set to the carburetors.
3. Run the engine at the specified idle speed and read the vacuum. The vacuum gauge readings should be the same on all four gauges.
4. To adjust, proceed as follows:
 - a. Remove the carburetor tops from the No. 1, 3 and 4 carburetors.
 - b. Loosen the lock nut and turn the adjusting screw until the vacuum reading becomes the same as the No. 2 carburetor reading.

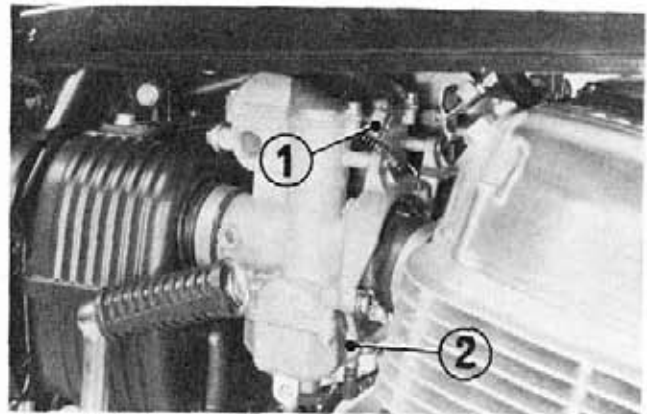


Fig. K7-15 ① Idle stop screw
② Pilot screw

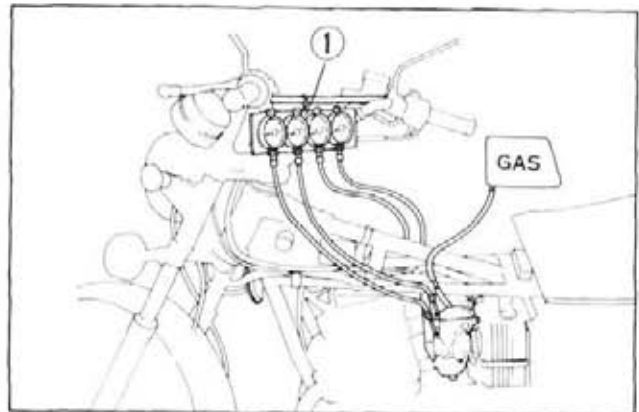


Fig. K7-16 ① Vacuum gauge set

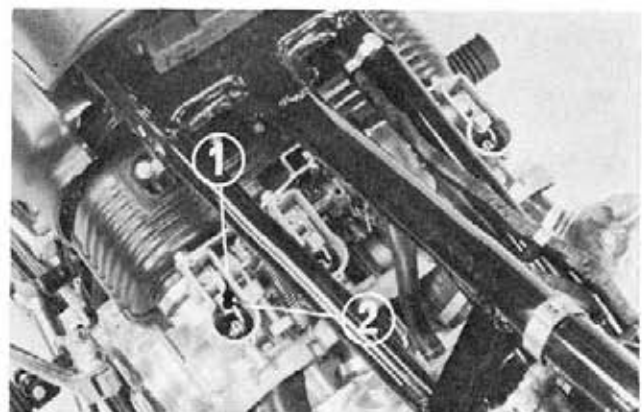


Fig. K7-17 ① Lock nut
② Adjusting screw

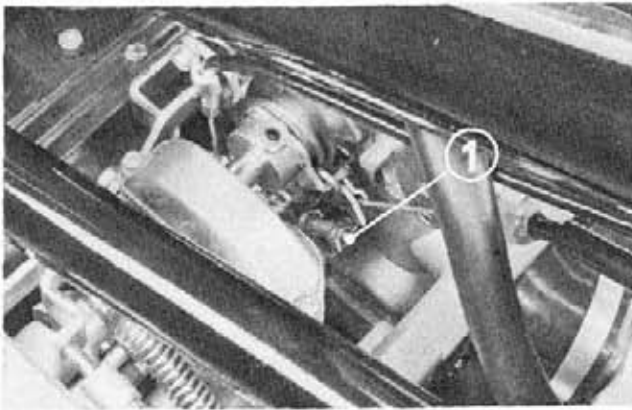


Fig. K7-19 ① Adjusting screw

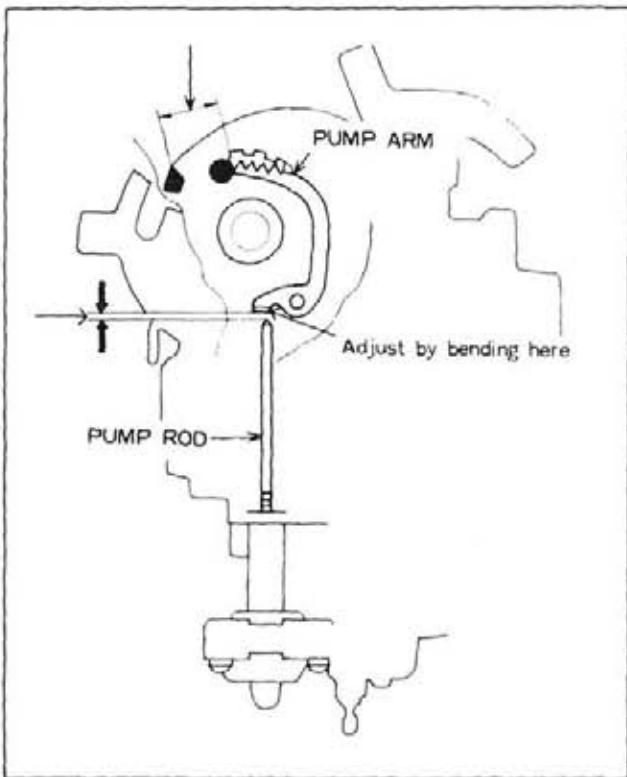


Fig. K7-20

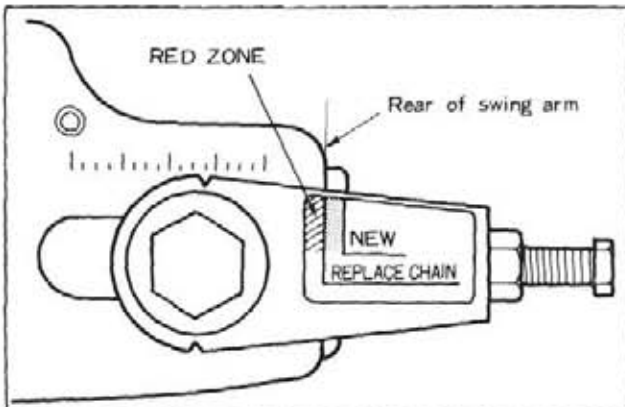


Fig. K7-21

Fast idle:

1. Remove the fuel tank.
 2. Pull the choke knob out fully and turn the adjusting screw until it touches the stopper.
 3. Push the choke knob in and turn the adjusting screw in 2-1/2 turns.
- Fast idle speed: 3,000~4,000rpm

Accelerator pump:

1. Remove the carburetor assembly from the engine.
2. Measure the pump rod-to-pump arm clearance with the throttle valve closed. The clearance should be 0 to 0.2 mm (0 to 0.008 in.). To adjust, bend the pump arm tang.
3. Measure the pump arm-to-carburetor stay clearance with the throttle valve closed. The clearance should be 9.5 to 10.5 mm (0.374 to 0.413 in.). To adjust, bend the pump arm.

2. DRIVE CHAIN

A. Inspection

1. Check for damaged rollers, loose pins, or missing O-rings. Replace if necessary.
2. Check for kinked, binding, dry, or rusted links. Lubricate only with SAE 80 or 90 gear oil, if necessary.

B. Adjustment

To adjust the drive chain, perform in the same manner described on page 186. Observe the following notes:

1. Drive chain tension: 20 mm (3/4 in.)
2. Check the chain wear label when adjusting the chain. If the red zone on the label aligns with the rear of the swing arm after the chain has been adjusted to 20 mm (3/4 in.) slack, the chain is excessively worn and must be replaced.



C. Lubricating and cleaning

The drive chain is equipped with O-rings. The O-rings can be damaged by steam cleaning, high pressure washers, and certain solvents. Clean the chain with kerosene. Wipe dry and lubricate only with SAE 80 or 90 gear oil. Commercial chain lubricants may contain solvents which could damage the rubber O-rings.

D. Replacement

The drive chain cannot be replaced by using a drive chain joint tool. Replace using the following procedure.

1. Remove the drive chain case and rear wheel.
2. Loosen the two 10 mm bolts that secure the rear shock absorbers to the rear swing arm.
3. Unscrew the rear fork pivot nut and pull out the rear fork pivot bolt. Remove the rear fork from the frame.
4. Remove the gear change pedal, transmission cover and left crankcase rear cover.

5. Remove the drive sprocket by loosening the 8 mm bolt. Remove the drive chain.

Replacement chain:

DID630DL or designation of RK630SD chain.

6. To install the drive chain, reverse the removal procedure described above.

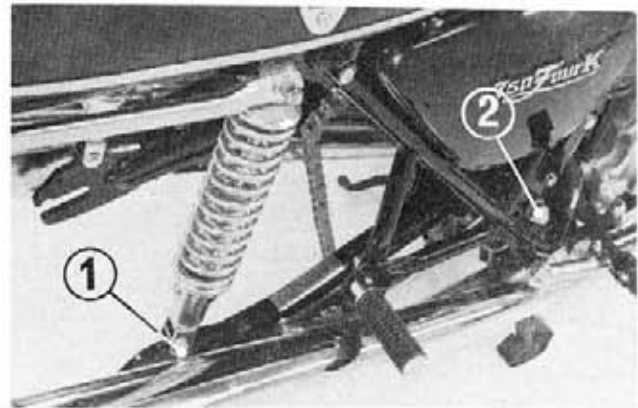


Fig. K7-22 ① 10 mm bolt
② Rear fork pivot nut

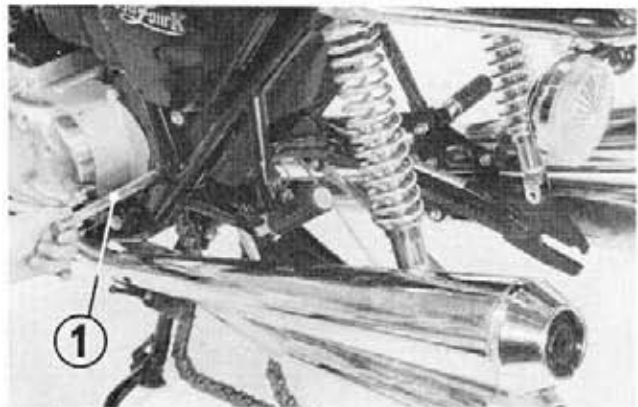


Fig. K7-23 ① Rear fork pivot bolt

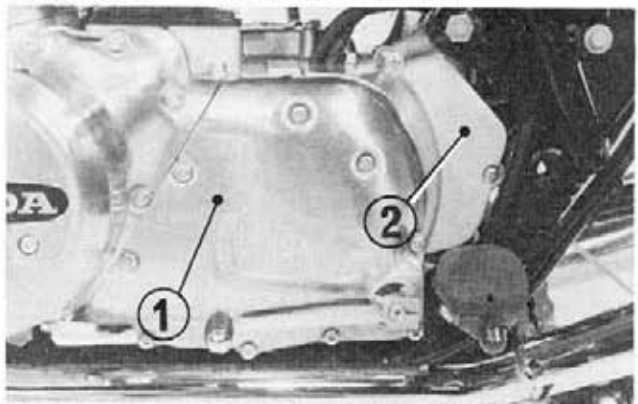


Fig. K7-24 ① Transmission cover
② Left crankcase rear cover

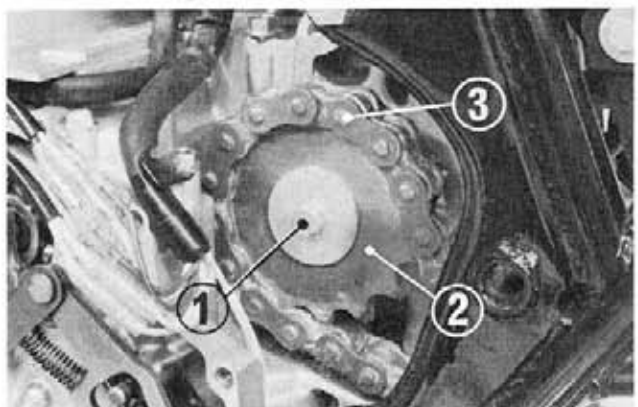


Fig. K7-25 ① 8 mm bolt
② Drive sprocket
③ Drive chain

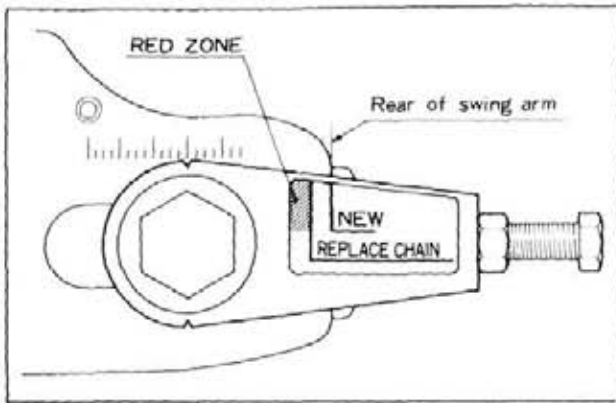


Fig. K7-26

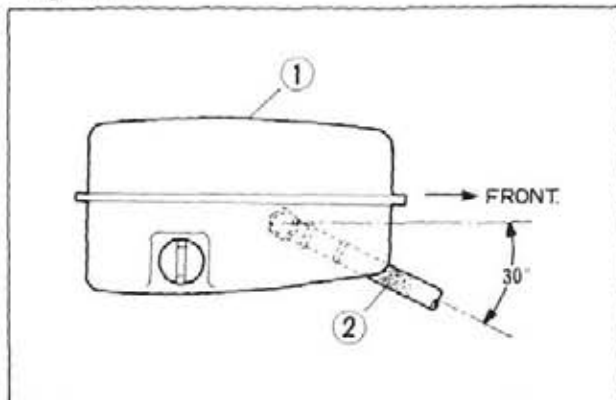
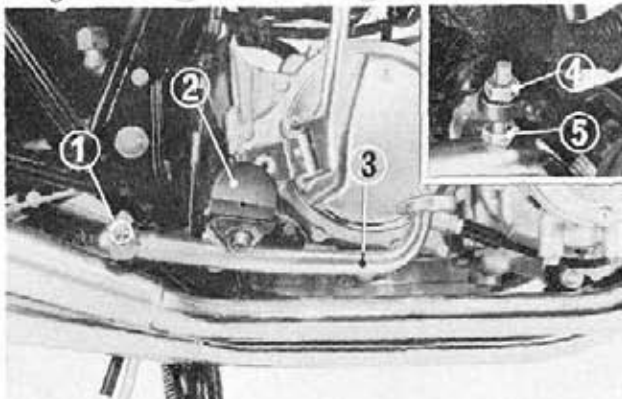
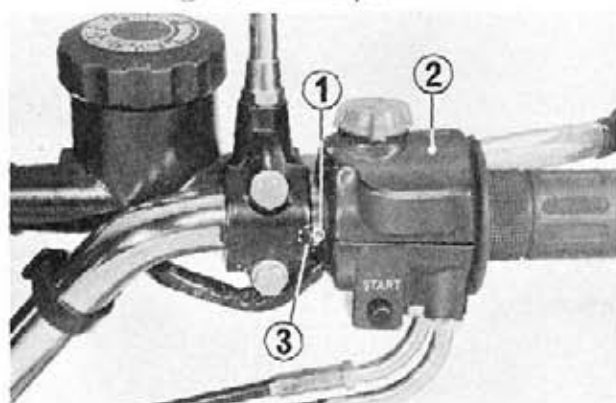


Fig. K7-27 ① Oil tank ② Suction hose

Fig. K7-28 ① Punch marks ④ Lock nut
② Foot peg ⑤ Stopper bolt
③ Rear brake pedalFig. K7-29 ① Punch mark
② Switch housing
③ Aligning mark on holder

7. Adjust the chain tension properly. Attach a new label to the left drive chain adjuster so that the right side end of the green zone aligns with the rear of the swing arm as shown in Fig. K7-26.

3. ENGINE OIL TANK

Connect the suction hose to the oil tank as shown in fig. K7-27 to prevent interference of the rear brake middle arm and the suction hose when the brake is applied.

4. REAR BRAKE PEDAL

A. Installation

Install the brake pedal so that the punch mark on the pedal is aligned with the punch mark on the rear brake spindle.

B. Adjustment

1. Adjust the brake pedal height so that the foot peg-to-pedal distance is 10 mm (0.4 in.). To adjust, loosen the lock nut and turn the stopper bolt in or out.
2. Adjust the pedal free play by turning the rear brake adjusting nut.
Free play: 20-30 mm (0.8-1.2 in.)

5. SWITCH HOUSING

When installing the right or left switch housing, align the mating edges of the housing with the punch mark on the handlebar and tighten the two screws securely.

The aligning mark on the brake lever bracket holder should be also lined up with the punch mark.

5. SERVICE DATA

A. Service data

| | Standard value | Service limit |
|---|----------------|---------------|
| Front shock absorber spring free length | 504.3 mm | 480 mm |
| Rear shock absorber spring free length | 232.9 mm | 220 mm |
| Front brake: Caliper cylinder I.D. | 42.85-42.90 mm | 42.91 mm |
| Caliper piston O.D. | 42.82 mm | 42.81 mm |

B. Torque specifications

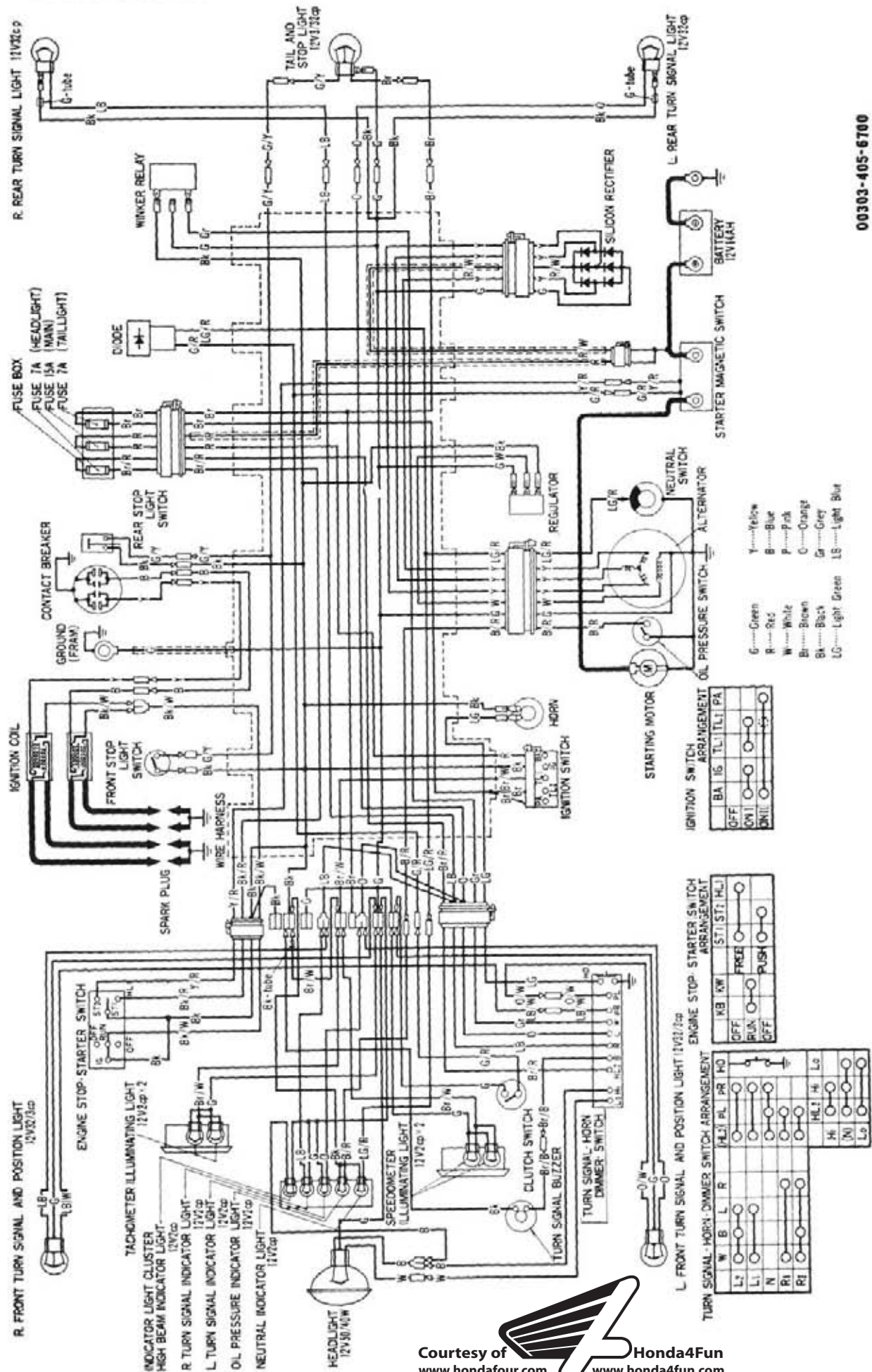
| | | | |
|--------------------|-------|----------------|-------------------|
| Connecting rod cap | 7 mm | 1.8- 2.2 kg-m | (13.0-15.9 lb-ft) |
| Cylinder head | 8 mm | 2.0- 2.5 kg-m | (14.5-18.1 lb-ft) |
| Flywheel | 12 mm | 10.0-12.0 kg-m | (72.3-86.7 lb-ft) |
| Drive sprocket | 8 mm | 1.8- 2.2 kg-m | (13.0-15.9 lb-ft) |
| Clutch center | 16 mm | 4.0- 4.2 kg-m | (28.9-30.4 lb-ft) |
| Upper crankcase | 8 mm | 2.0- 2.5 kg-m | (14.5-18.1 lb-ft) |
| Lower Crankcase | 8 mm | 2.0- 2.5 kg-m | (14.5-18.1 lb-ft) |
| Cam sprocket | 7 mm | 1.8- 2.2 kg-m | (13.0-15.9 lb-ft) |

6. SPECIFICATION (CB750K '77)

| Item | |
|--------------------------|--|
| DIMENSION | |
| Overall Length | 2,280 mm (89.8 in.) |
| Overall Width | 880 mm (34.6 in.) |
| Overall Height | 1,185 mm (46.7 in.) |
| Wheel Base | 1,495 mm (58.9 in.) |
| Seat Height | 810 mm (31.9 in.) |
| Foot Peg Height | 330 mm (13.0 in.) |
| Ground Clearance | 150 mm (5.9 in.) |
| Dry Weight | 231 kg (508 lb.) |
| FRAME | |
| Type | Double Cradle |
| F. Suspension, Travel | Telescopic fork, travel 141.5 mm (5.6 in.) |
| R. Suspension, Travel | Swing arm, travel 101.6 mm (4.0 in.) |
| F. Tire Size, Type | 3.50 H-19-4 PR Rib, tire air pressure 2.0/2.0 kg/cm ² (28/28 psi) |
| R. Tire Size, Type | 4.50 H-17A-4 PR Block, tire air pressure 2.25/2.8 kg/cm ² (32/40 psi) |
| F. Brake | Disk Brake |
| R. Brake | Internal expanding shoe |
| Fuel Capacity | 19 lit. (5.0 U.S. gal. 4.2 Imp. gal.) |
| Fuel Reserve Capacity | 4 lit. (1.1 U.S. gal. 0.9 Imp. gal.) |
| Caster Angle | 62° |
| Trail Length | 115 mm (4.5 in.) |
| Front Fork Oil Capacity | 145~155 cc (5.3~5.4 ozs.) |
| ENGINE | |
| Type | Air cooled 4 stroke O.H.C. engine |
| Cylinder Arrangement | 4 cylinder in line |
| Bore and Stroke | 61.0×63.0 mm (2.402×2.480 in.) |
| Displacement | 736 cc (44.9 cu in.) |
| Compression Ratio | 9.2 : 1 |
| Carburetor, Venturi Dia. | Four piston valve type, venturi dia. 28 mm (1.102 in.) |
| Valve Train | Chain driven over head cam shaft |
| Oil Capacity | 3.5 lit. (3.7 U.S. qt 3.1 Imp. qt) |
| Lubrication System | Forced pressure and dry sump |
| Fuel Required | Low-lead gasoline with 91 octane number or higher |
| Air Filtration | Paper filter |
| Intake Valve: Opens | 0° BTDC |
| Closes | 40° ATDC |
| Exhaust Valve: Opens | 40° BBDC |
| Closes | 0° ATDC |
| Valve Tappet Clearance | IN: 0.05 EX: 0.08 mm (IN: 0.002, EX: 0.003 in.) |
| Pilot Screw Opening | Fixed by idle limiter (1-1/2±1/2) |
| Idle Speed | 1,000 rpm |

| Item | |
|------------------------------|--|
| DRIVE TRAIN | |
| Clutch | Wet multi plate type |
| Transmission | 5-speed constant mesh |
| Primary Reduction | 1.708 |
| Gear Ratio I | 2.500 |
| II | 1.708 |
| III | 1.333 |
| IV | 1.133 |
| V | 0.969 |
| Final Reduction | 2.733, drive sprocket 15 T, driven sprocket 41 T |
| Gear Shift Pattern | Left foot operated return system |
| ELECTRICAL | |
| Ignition | Battery and ignition coil |
| Ignition Advance: | |
| "F" mark | 10° BTDC |
| Max. advance | 35° |
| RPM from "F" to max. advance | 1,200-2,500 rpm |
| Dwell Angle | 190° ± 5° |
| Starting System | Starting motor or kick starter |
| Alternator | Three phase AC Generator 0.21 kW/5,000 rpm |
| Battery Capacity | 12 V-14 AH |
| Fuse Capacity | Main: 15 amp. Head: 7 A Tail: 5 A |
| Spark plug | NGK D8ES-L ND X24ES (U.S.A. model) |
| | NGK DR8ES-L ND X24ESR (Canadian model) |
| Condenser Capacity | 0.20-0.24 μF |

7. WIRING DIAGRAM



00303-405-6700

SUPPLEMENT TO CB750F2 ('77)

Engine No. CB750E—2600004 and
subsequent
Frame No. CB750F—2100001 and
subsequent

GROUP
25

1. FRONT BRAKE

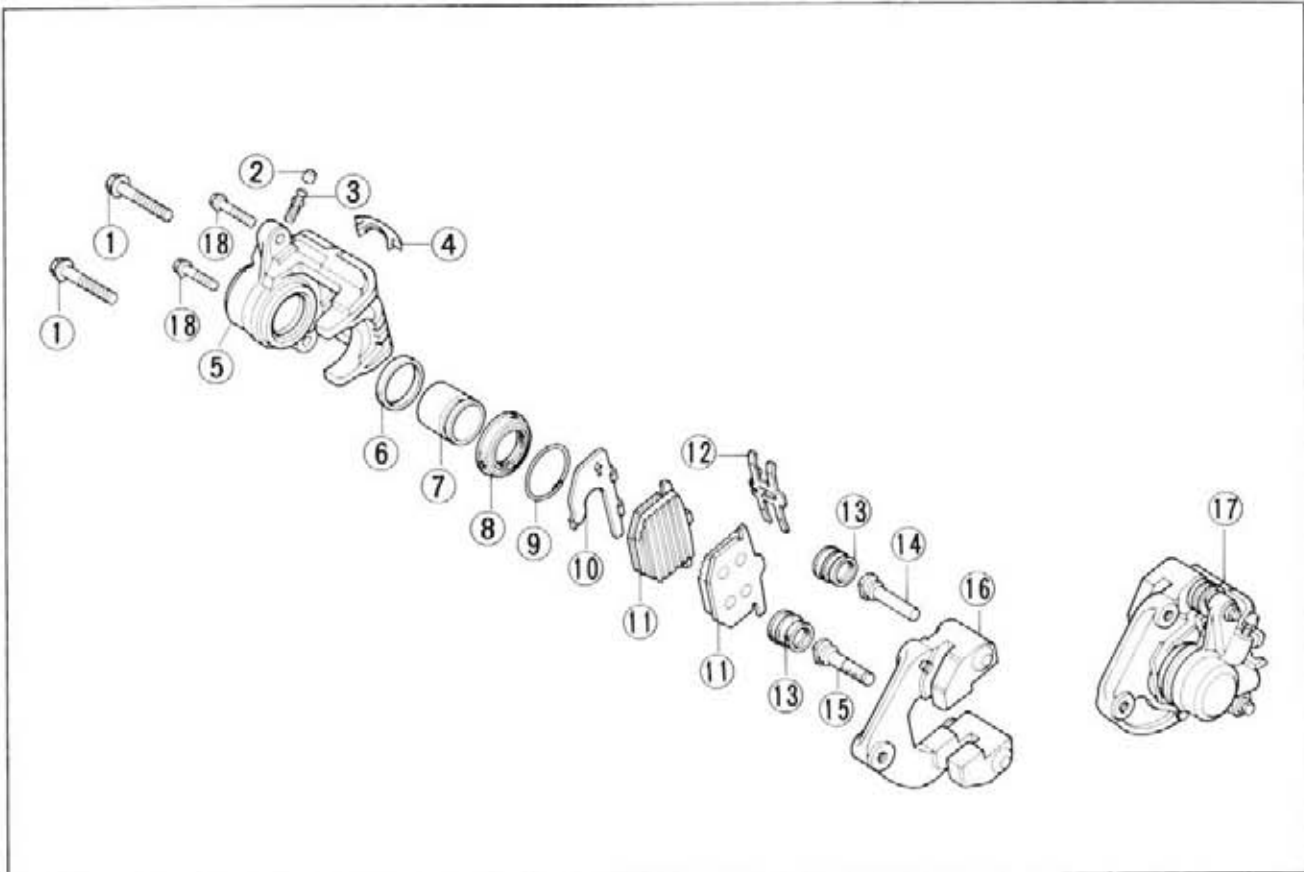


Fig. F2-1

| | | | |
|-----------------------|--------------------|--------------|-------------------------|
| ① Flange bolt (10×32) | ⑥ Piston seal | ⑪ Brake pad | ⑱ Right bracket |
| ② Bleed valve cap | ⑦ Piston | ⑫ Pad spring | ⑳ Left caliper assembly |
| ③ Bleed valve | ⑧ Piston boot | ⑬ Dust cover | |
| ④ Indicator cap | ⑨ Piston boot clip | ⑭ Pin A | |
| ⑤ Right caliper | ⑩ Pad shim | ⑮ Pin B | |
| | | | |

A. Disassembly

1. Remove the oil bolt and disconnect the front brake hose from the caliper.
2. Remove the two 8mm flange bolts and caliper from the bracket.

NOTE: It is not necessary to remove the oil bolt to replace the brake pads.

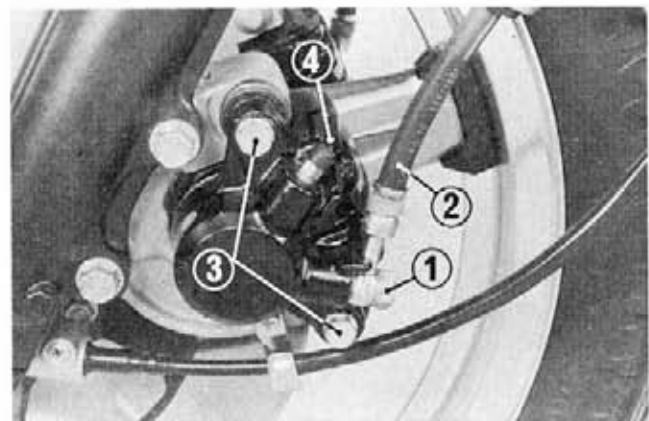


Fig. F2-2

| | |
|--------------|-------------------|
| ① Oil bolt | ③ 8mm flange bolt |
| ② Brake hose | ④ Caliper |

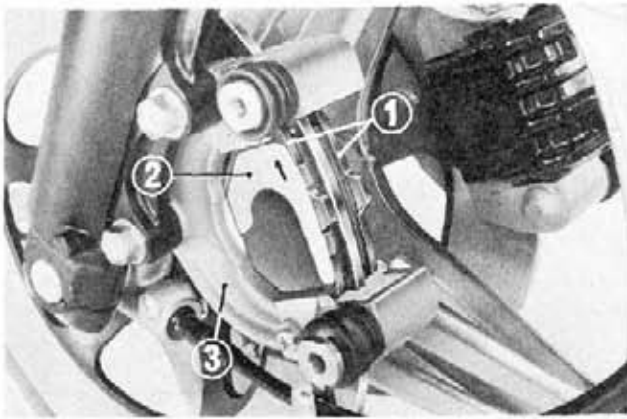


Fig. F2-3 ① Brake pad ② Shim ③ Caliper holder

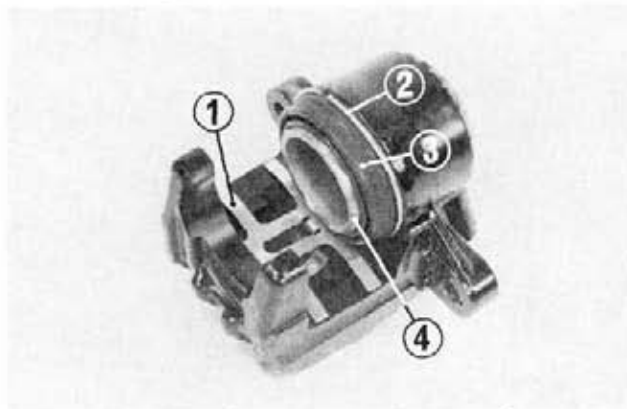


Fig. F2-4 ① Pad spring ② Boot clip ③ Piston boot ④ Piston

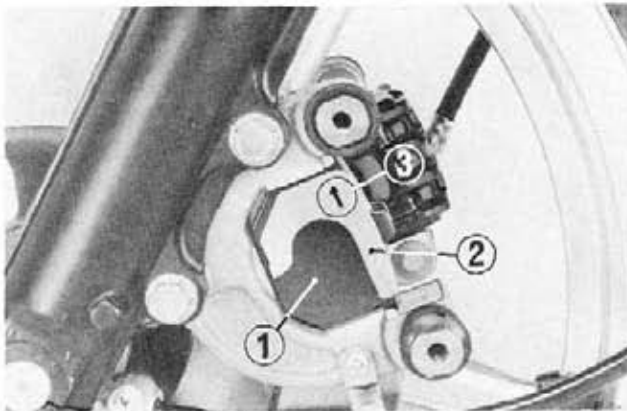


Fig. F2-5 ① Brake pad ② Shim ③ Arrow

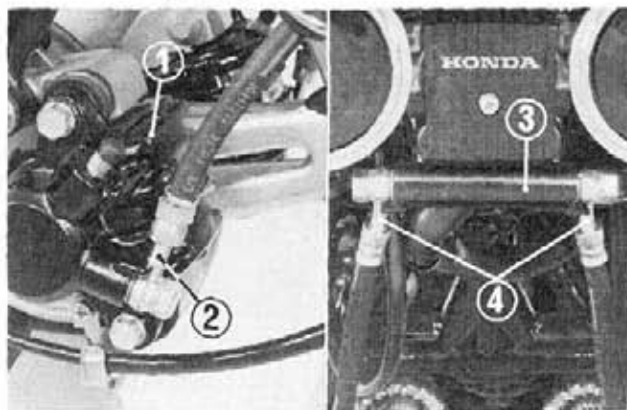


Fig. F2-6 ① Caliper ② Straight side ③ Three way joint ④ Bent side

3. Remove the brake pads and shim from the caliper holder.
4. Remove the pad spring from the caliper.
5. Remove the boot clip and piston boot. Apply compressed air in the caliper fluid inlet and remove the piston.

B. Assembly

To assemble, reverse the disassembly procedure. Observe the following notes.

1. Install the shim on the outside pad so that its arrow is in the normal rotating direction.
2. Install the brake hose so that the straight side of the hose ends is at the caliper and bent side is at the three way joint as shown in Fig. F2-6.

C. Brake pad inspection

Remove the wear indicator cap and check the brake pads for wear. If the pad is worn to the red line, replace all front pads as a set.

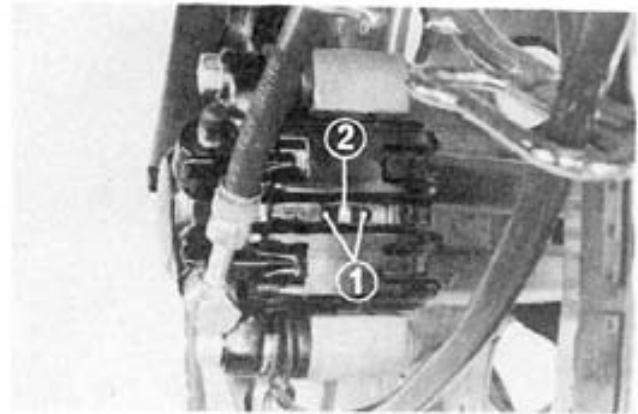


Fig. F2-7 ① Red line ② Brake disc

2. FRONT BRAKE SWITCH

The front brake switch has been modified from the hydraulic switch to the mechanical switch.



Fig. F2-8 ① front brake switch

3. REAR BRAKE

A. Pedal free height adjustment

To adjust the brake pedal free height, remove the rubber cap by inserting a screw driver in the groove, loosen the lock nut and turn the adjuster as necessary. Turning the adjuster clockwise will decrease the pedal height, and turning it counterclockwise will result in a increase. After adjustment, tighten the lock nut securely and install the rubber cap.

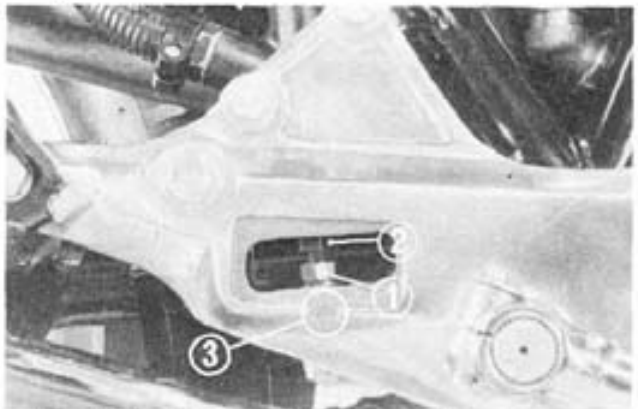


Fig. F2-9 ① Lock nut ② Adjuster ③ Groove

B. Rear brake hose

The brake hose is installed so that the bent side of the hose ends is at the caliper as shown in Fig. F2-10.

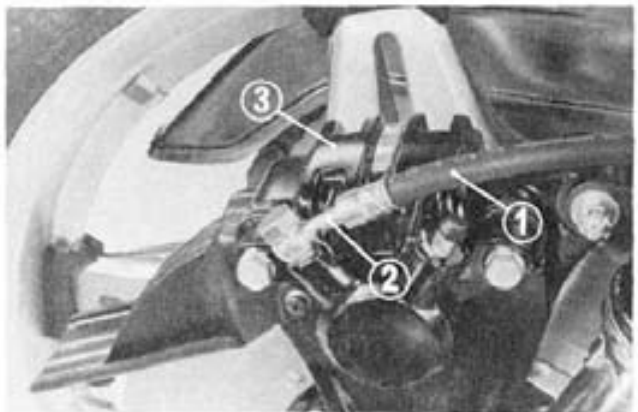


Fig. F2-10 ① Brake hose ② Bent side ③ Caliper

4. FRONT WHEEL

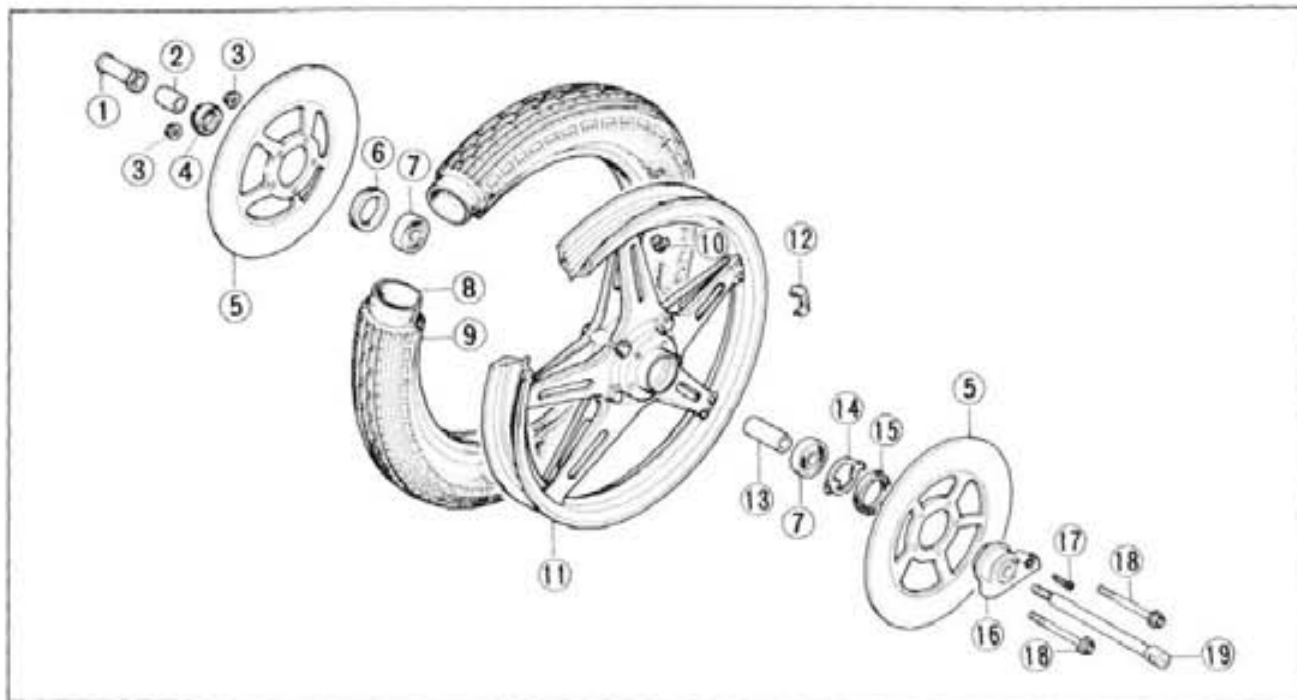


Fig. F2-11

| | | |
|--------------------------------|----------------------------|------------------------|
| ① Axle nut (12mm) | ⑧ Tire tube | ⑭ Gear box retainer |
| ② Front wheel side collar | ⑨ Front wheel tire | ⑮ Dust seal (40×50×5) |
| ③ Hex. nut (8mm) | ⑩ Wheel balance weight | ⑯ Speedometer gear box |
| ④ Dust seal (40×50×5) | ⑪ Front wheel rim assembly | ⑰ Screw (5×16) |
| ⑤ Front brake disc | ⑫ Spoke plate mark | ⑱ Flange bolt (8×100) |
| ⑥ Front wheel bearing retainer | ⑬ Distance collar | ⑲ Front wheel axle |
| ⑦ Radial ball bearing (6302U) | | |

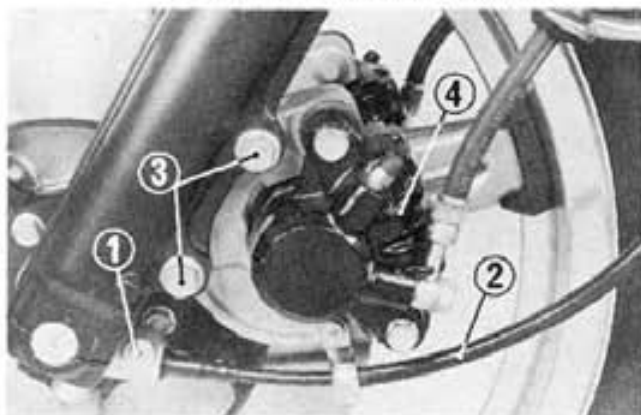


Fig. F2-12

| | |
|---------------------|-------------|
| ① Screw | ③ 10mm bolt |
| ② Speedometer cable | ④ Caliper |

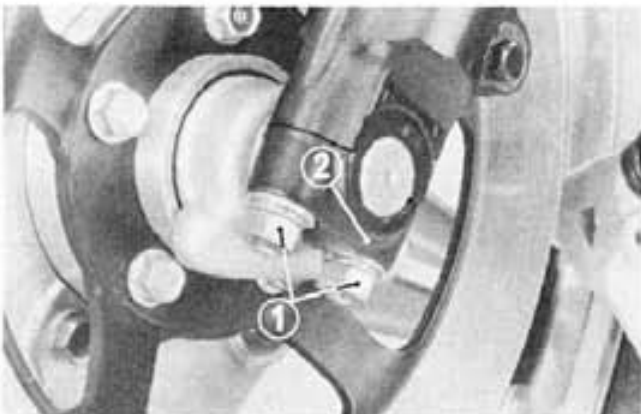


Fig. F2-13

| | |
|-------------------|---------------|
| ① Axle holder nut | ② Axle holder |
|-------------------|---------------|

A. Disassembly

1. Place a support block under the engine to raise the front wheel off the ground.
2. Remove the screw and remove the speedometer cable from the gear box.
3. Remove the four 10mm bolts and caliper assemblies from the front forks.

NOTE: Do not depress the brake lever when the wheel is off the motorcycle.

4. Remove the front axle holder nuts and remove the front axle holders.
5. Remove the front wheel.
6. Remove the front brake discs by loosening the five 8mm nuts and bolts.
7. Remove the wheel bearing retainer with special tool (Bearing Retainer Wrench; Tool No. HC 37592). Then remove the gear box retainer, retaining bearings and distance collar.
8. Remove the dust seals if replacement is required.

NOTE: Do not disassemble the front wheel rim assembly.

B. Assembly

To assemble, reverse the disassembly procedure. However, install the front wheel assembly as follows.

1. Position the wheel assembly between the fork legs, making sure that the speedometer gear box is properly positioned. Lower the fork lightly so that the hollows in the fork legs rest on top of the axle.
2. Install the axle holders with the "F" mark forward and tighten the forward axle holder nuts lightly.
3. Fit the caliper over the discs taking care not to damage the brake pads. Install the caliper mounting bolts and tighten to the specified torque.
Specified torque: 3.0-4.0kg-m (22-29lbs-ft.)
4. Tighten the nuts on the right axle holder to the specified torque starting with the forward nuts.
Specified torque: 1.8-2.5kg-m (13-18lbs-ft.)

5. Measure the clearance between the outside surface of the left brake disc and the rear of the left caliper holder with a 0.7mm (0.028in.) feeler gauge. If the gauge inserts easily, first tighten the forward axle holder nut to the specified torque, then the rear nut. If the feeler gauge cannot be inserted easily, pull the left fork outward until the gauge can be inserted and tighten the holder nuts with the gauge inserted. After tightening, remove the gauge.
6. Check that the other three corners of the left caliper holder have a clearance of at least 0.7mm (0.028in.) between caliper holder and disc.
7. After installing the wheel, apply brakes several times and recheck both discs for caliper holder to disc clearance.

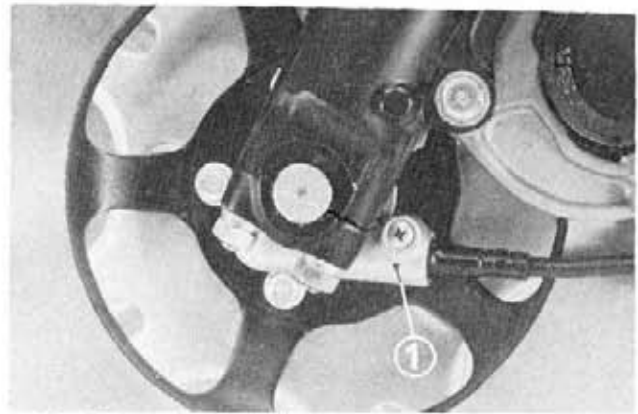


Fig. F2-14 ① Speedometer gear box

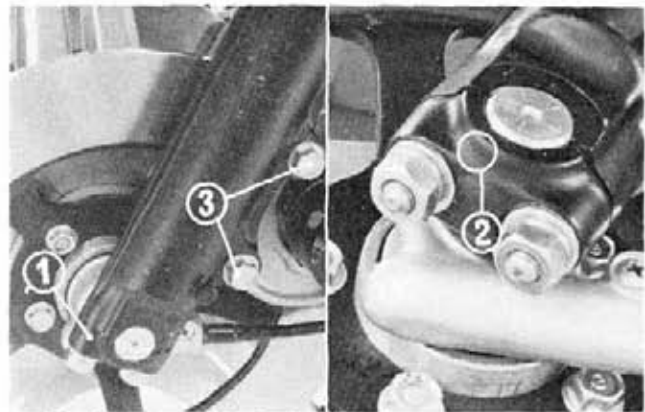


Fig. F2-15 ① Axle holder
② "F" mark
③ Caliper mounting bolt

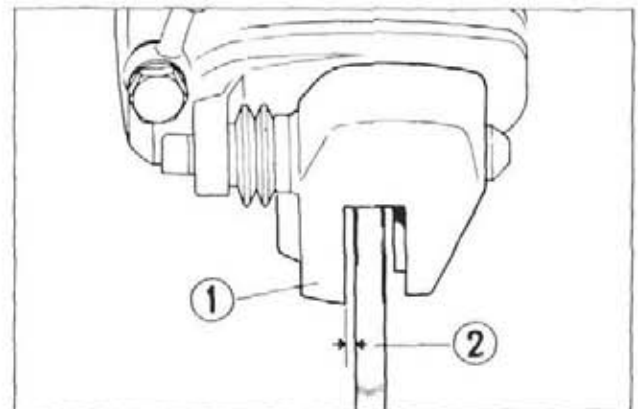


Fig. F2-16 ① Caliper holder ② Disc

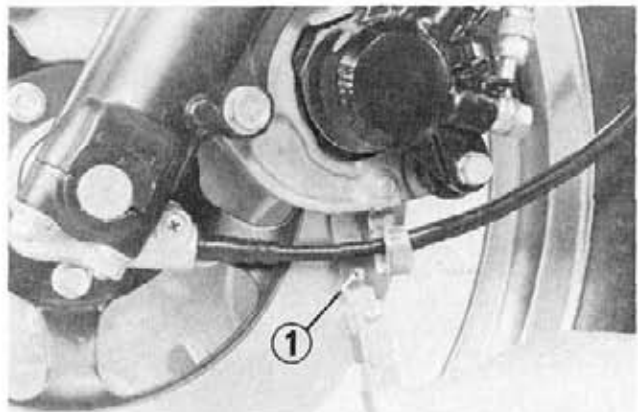


Fig. F2-17 ① Feeler gauge

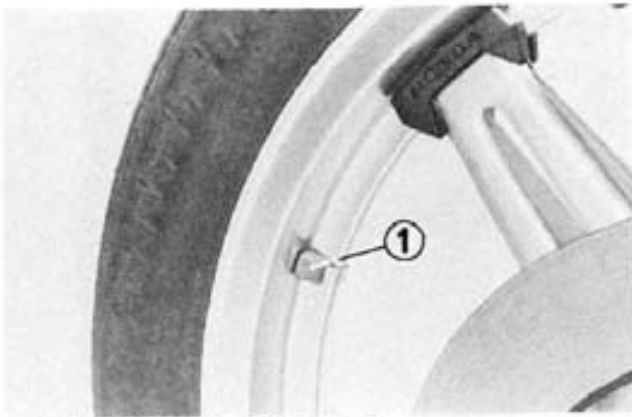


Fig. F2-18 ① Balance weight

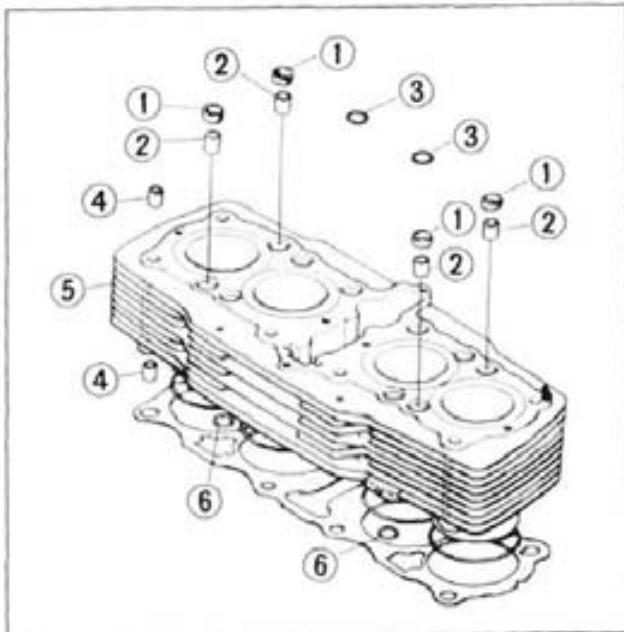


Fig. F2-19 ① Stud bolt packing
 ② Special knock pin (12mm)
 ③ O-ring (11×2.5)
 ④ Dowel pin (12×18)
 ⑤ Cylinder
 ⑥ O-ring

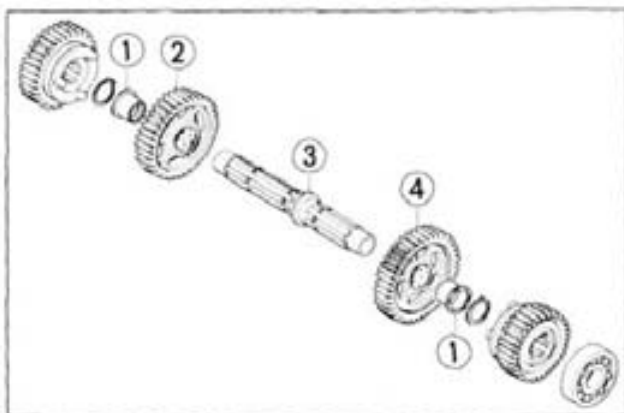


Fig. F2-20 ① 28mm bushing
 ② Countershaft 3rd gear
 ③ Countershaft
 ④ Countershaft 2nd gear

C. Wheel balance

(Refer to page 228.)

Install the balance weight on the rim flange as shown in Fig. F2-18.

Balance weight: 20g (0.7 oz.)
 30g (1.0 oz.)

5. CYLINDER

The 12mm special knock pins and cylinder stud bolt packings have been decreased from eight to four.

6. TRANSMISSION

The countershaft thrust washers have been integrated into the gear bushings.

7. CARBURETOR

Refer to page 253.

Carburetor setting table

| Item | |
|--------------------|-------------------|
| Main jet No. | ≈105 |
| Air jet No. | ≈120 |
| Slow jet No. | ≈35 |
| Slow air jet No. | ≈150 |
| Jet needle setting | F2051F-2 |
| Float height | 14.5mm (0.571in.) |

8. DRIVE CHAIN

Refer to page 258.

9. SWITCH HOUSING

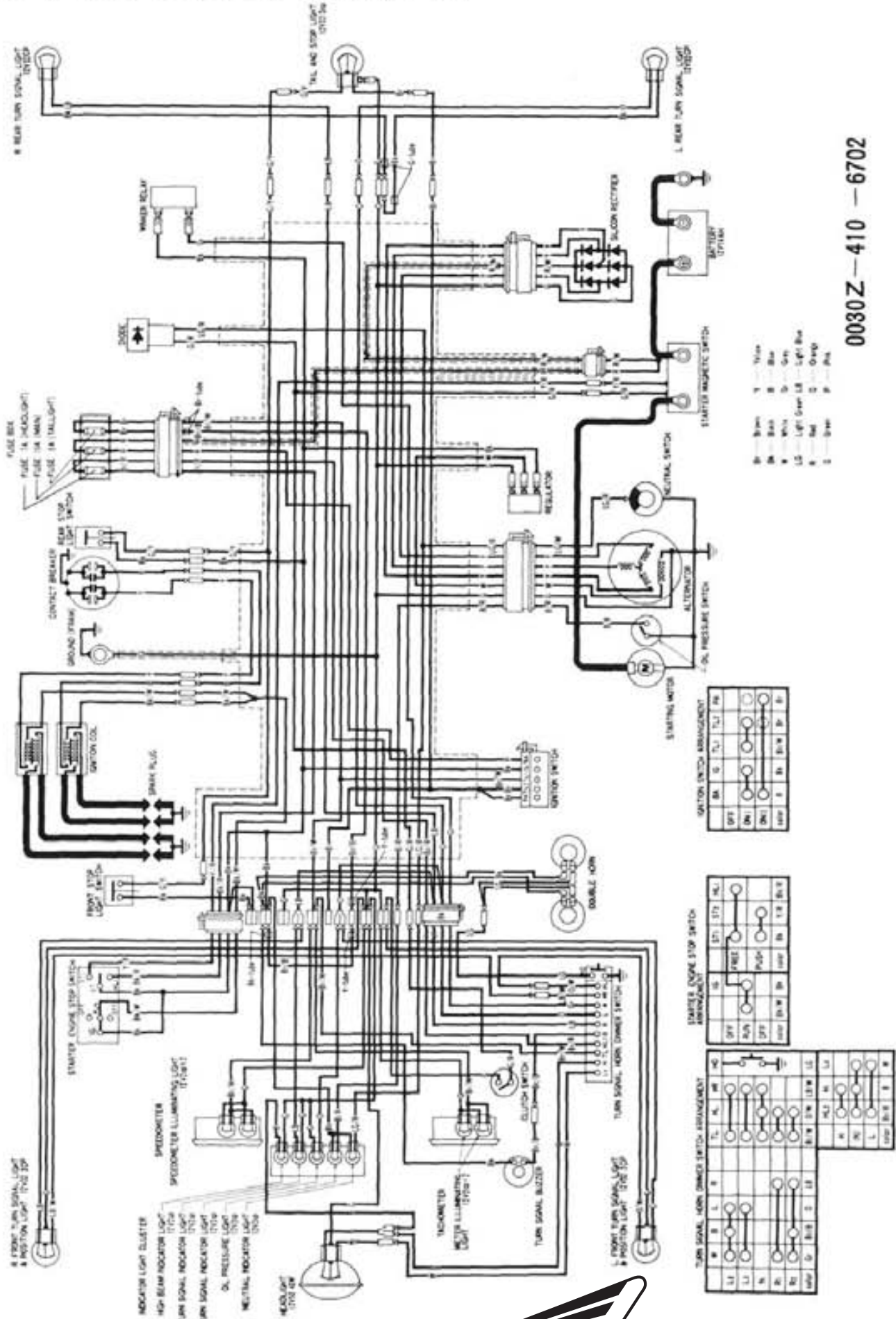
Refer to page 260.

10. SPECIFICATIONS (CB750F2 '77)

| Item | |
|--------------------------|---|
| DIMENSION | |
| Overall length | 2,210 mm (87.0 in.) |
| Overall width | 860 mm (33.9 in.) |
| Overall height | 1,185 mm (46.7 in.) |
| Wheelbase | 1,480 mm (58.3 in.) |
| Seat height | 830 mm (32.7 in.) |
| Foot peg height | 325 mm (12.8 in.) |
| Ground clearance | 135 mm (5.3 in.) |
| Dry weight | 232.5 kg (512.6 lb.) |
| FRAME | |
| Type | Double cradle |
| Front suspension, travel | Telescopic fork, travel 141.5 mm (5.6 in.) |
| Rear suspension, travel | Swing arm, travel 86.3 mm (4.0 in.) |
| Front tire size, type | 3.25H-19-4PR, Rib |
| air pressure | Up to 90 kg (200 lb) load: 2.0 kg/cm ² (28 psi) |
| | Up to vehicle capacity load: 2.25 kg/cm ² (32 psi) |
| Rear tire size, type | 4.00H-18-4PR Block |
| air pressure | Up to 90 kg (200 lb) load: 2.0 kg/cm ² (28 psi) |
| | Up to vehicle capacity load: 2.8 kg/cm ² (40 psi) |
| Front brake | Disc brake |
| Rear brake | Disc brake |
| Fuel capacity | 18 lit. (4.8 U.S. gal., 4.0 Imp. gal.) |
| Fuel reserve capacity | 4.5 lit. (1.2 U.S. gal., 1.0 Imp. gal.) |
| Caster angle | 62.5° |
| Trail length | 113.5 mm (4.47 in.) |
| Front fork oil capacity | 145-155 cc (5.3-5.4 ounces.) |
| ENGINE | |
| Type | Air cooled 4 stroke O.H.C. engine |
| Cylinder arrangement | 4 cylinder in line |
| Bore and stroke | 61.0×63.0 mm (2.402×2.480 in.) |
| Displacement | 736 cc (44.9 cu in.) |
| Compression ratio | 9.0 : 1 |
| Carburetor, venturi dia. | Four piston valve type, venturi dia. 28 mm (1.102 in.) |
| Valve train | Chain driven over head camshaft |
| Oil capacity | 3.5 lit. (3.7 U.S. qt., 3.1 Imp. qt.) |
| Lubrication system | Forced pressure and dry sump |
| Fuel required | Low-lead gasoline with 91 octane rating or higher |
| Air cleaner | Paper filter |
| Intake valve: opens | 5° BTDC |
| closes | 40° ATDC |
| Exhaust valve: opens | 40° BBDC |
| closes | 5° ATDC |
| Valve tappet clearance | IN: 0.05 mm (0.002 in.), EX: 0.08 mm (0.003 in.) |
| Pilot screw opening | Fixed by idle limiter (1.1/2±1/2) |
| Idle speed | 1,000 rpm |

| Item | |
|------------------------------|--|
| DRIVE TRAIN | |
| Clutch | Wet multi plate type |
| Transmission | 5-speed constant mesh |
| Primary reduction | 1.708 |
| Gear ratio: 1st | 2.500 |
| " " 2nd | 1.708 |
| " " 3rd | 1.333 |
| " " 4th | 1.133 |
| " " 5th | 0.969 |
| Final reduction | 3.071 |
| Gearshift pattern | Left foot operated return system |
| ELECTRICAL | |
| Ignition | Battery and ignition coil |
| Ignition advance: | |
| "F" mark | 10° BTDC |
| Max. advance | 35° |
| RPM from "F" to max. advance | 1,200-2,500 rpm |
| Dwell angle | 190° ± 5° |
| Starting system | Starting motor or kick starter |
| Alternator | Three phase AC generator 0.21 kw/5,000 rpm |
| Battery capacity | 12 V-14 AH |
| Fuse capacity | Main: 15 A, Head: 7 A, Tail: 5 A |
| Spark plug | U.S.A. model: NGK D8ES-L or ND X24ES |
| Condenser capacity | Canadian model: NGK DR8ES-L or ND X24ESR-U 0.22-0.26 μF |

11. WIRING DIAGRAM (CB750F2 '77)



0030Z-410-6702

SUPPLEMENT TO CB750K8 '78)

Engine No. CB750E—3000001 and
subsequent

Frame No. CB750K—2800001 and
subsequent

GROUP
26

1. AIR CLEANER

Breather Element Cleaning

1. Remove the left side cover, chain protector and diode rectifier. Remove the 6mm breather element case mounting bolt, disconnect the breather tubes and remove the breather element case.
2. Loosen the four screws and remove the case cover.
3. Remove the retaining plate and breather element from the case.

CAUTION

Be careful not to damage the retaining plate.

4. Wash the breather element in clean solvent and dry the element thoroughly.

WARNING

Gasoline or low flash point solvents are explosive and highly flammable and must not be used to clean the breather element. Fire or explosion could result.

NOTE: When installing the case cover, position it as shown in Fig. K8-3.

2. CARBURETOR

Carburetor Setting Table

| | |
|---------------------|---------------------|
| Setting number | PD42B |
| Main jet | No. 110 |
| Slow jet | No. 35 |
| Pilot screw opening | 1-1/2 |
| Float height | 14.5 mm (0.571 in.) |

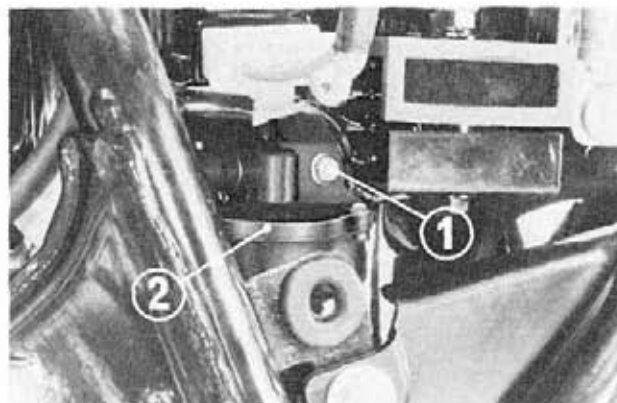


Fig. K8-1 ① Mounting bolt
② Breather element case

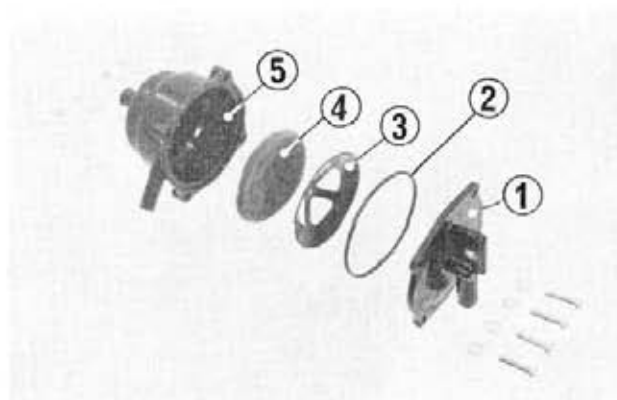


Fig. K8-2 ① Case cover
② O-ring
③ Retaining plate
④ Breather element
⑤ Element case

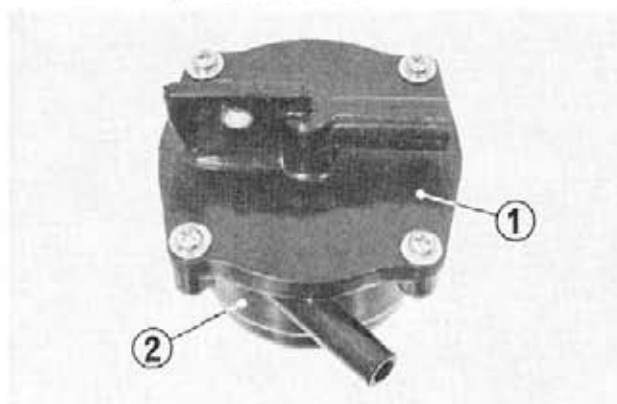


Fig. K8-3 ① Case cover
② Element case

3. MAINTENANCE

Perform the Pre-Ride Inspection described in the Owner's Manual at each maintenance period.

I: INSPECT, CLEAN, ADJUST, OR REPLACE IF NECESSARY.

C: CLEAN

R: REPLACE

A: ADJUST

| ITEM | FREQUENCY | WHICHEVER COMES FIRST ↓ EVERY | ODOMETER READING [NOTE (3)] | | | | | | REFER TO |
|------------------------------------|-----------|-------------------------------------|--------------------------------------|------------------------|-------------------------|--------------------------|--------------------------|--------------------------|----------|
| | | | 600 mi (1,000 km) | 3,600 mi (6,000 km) | 7,200 mi (12,000 km) | 10,800 mi (18,000 km) | 14,400 mi (24,000 km) | 18,000 mi (30,000 km) | |
| ENGINE OIL | YEAR | R | REPLACE EVERY 1,800 mi (3,000 km) | | | | | | Page 178 |
| ENGINE OIL FILTER | YEAR | R | R | R | R | R | R | Page 178 | |
| * ENGINE OIL SCREEN | | | | | | C | | Page 179 | |
| CRANKCASE BREATHER | NOTE (1) | | C | C | C | C | C | Page 274 | |
| AIR CLEANER | NOTE (2) | | C | R | C | R | C | Page 226 | |
| * FUEL LINES | | | I | I | I | I | I | Pages 181, 221 | |
| SPARK PLUGS | | | I | R | I | R | I | Pages 89, 179 | |
| * VALVE CLEARANCE | | | I | I | I | I | I | Page 181 | |
| * CONTACT BREAKER POINTS | | | I | I | I | I | I | Page 180 | |
| * IGNITION TIMING | | | I | I | I | I | I | Page 180 | |
| * CAMCHAIN TENSION | | A | A | A | A | A | A | Page 181 | |
| * THROTTLE OPERATION | | | I | I | I | I | I | Page 196 | |
| * CARBURETOR IDLE SPEED | | | I | I | I | I | I | Pages 257, 274 | |
| * CARBURETOR CHOKE/ (FAST IDLE) | | | I | I | I | I | I | Page 258 | |
| * CARBURETOR SYNCHRONIZE | | | I | I | I | I | I | Page 257 | |
| DRIVE CHAIN | | | INSPECT EVERY 600 mi (1,000 km) | | | | | | Page 258 |
| BATTERY ELECTROLYTE | MONTH | | I | I | I | I | I | Page 184 | |
| BRAKE FLUID LEVEL | MONTH | | I | I | I | I | I | | |
| * BRAKE FLUID | 2 YEARS | | | | | R | | Pages 146~147 | |
| BRAKE SHOE/PAD WEAR | | | I | I | I | I | I | Page 217 | |
| BRAKE FREE PLAY | | | I | I | I | I | I | Pages 149, 217 | |
| * BRAKE LIGHT SWITCH | | | I | I | I | I | I | Page 188 | |
| * HEADLIGHT AIM | | | I | I | I | I | I | Page 187 | |
| CLUTCH FREE PLAY | | | I | I | I | I | I | Page 183 | |
| SIDE STAND | | | I | I | I | I | I | Page 222 | |
| * SUSPENSION | | | I | I | I | I | I | Pages 184~185, 250 | |
| * NUTS, BOLTS, FASTENERS | | | I | I | I | I | I | | |
| ** WHEELS/SPOKES | | | I | I | I | I | I | Pages 133, 135, 138 | |
| ** STEERING HEAD BEARING | | | I | | | I | | Page 118 | |

** IN THE INTEREST OF SAFETY, WE RECOMMEND THESE ITEMS BE SERVICED ONLY BY AN AUTHORIZED HONDA DEALER.

* SHOULD BE SERVICED BY AN AUTHORIZED HONDA DEALER, UNLESS THE OWNER HAS PROPER TOOLS AND SERVICE DATA, AND IS MECHANICALLY QUALIFIED.

NOTES: (1) More frequent service may be required when riding in rain, or at full throttle.

(2) More frequent service may be required when riding in dusty areas.

(3) For higher odometer readings, repeat at the frequency interval established here.

4. SPECIFICATIONS

| Item | |
|--------------------------|--|
| DIMENSION | |
| Overall Length | 2,280 mm (89.8 in.) |
| Overall Width | 880 mm (34.6 in.) |
| Overall Height | 1,185 mm (46.7 in.) |
| Wheel Base | 1,495 mm (58.9 in.) |
| Seat Height | 810 mm (31.9 in.) |
| Foot Peg Height | 330 mm (13.0 in.) |
| Ground Clearance | 150 mm (5.9 in.) |
| Dry Weight | 231 kg (508 lb.) |
| FRAME | |
| Type | Double Cradle |
| F. Suspension, Travel | Telescopic fork, travel 141.5 mm (5.6 in.) |
| R. Suspension, Travel | Swing arm, travel 101.6 mm (4.0 in.) |
| F. Tire Size, Type | 3.50H-19-4PR Rib, tire air pressure 2.0/2.0 kg/cm ² (28/28 psi) |
| R. Tire Size, Type | 4.50H-17A-4PR Block, tire air pressure 2.25/2.8 kg/cm ² (32/40 psi) |
| F. Brake | Disk Brake |
| R. Brake | Internal expanding shoe |
| Fuel Capacity | 19.5 lit. (5.1 U.S. gal., 4.3 Imp. gal.) |
| Fuel Reserve Capacity | 4.0 lit. (1.1 U.S. gal., 0.9 Imp. gal.) |
| Caster Angle | 62° |
| Trail Length | 115 mm (4.5 in.) |
| Front Fork Oil Capacity | 145~155 cc (5.3~5.4 ozs.) |
| ENGINE | |
| Type | Air cooled 4 stroke O.H.C. engine |
| Cylinder Arrangement | 4 cylinder in line |
| Bore and Stroke | 61.0×63.0 mm (2.402×2.480 in.) |
| Displacement | 736 cc (44.9 cu in.) |
| Compression Ratio | 9.2 : 1 |
| Carburetor, Venturi Dia. | Four piston valve type, venturi dia 28 mm (1.102 in.) |
| Valve Train | Chain driven over head cam shaft |
| Oil Capacity | 3.5 lit. (3.7 U.S. qt., 3.1 Imp. qt.) |
| Lubrication System | Forced pressure and dry sump |
| Fuel Required | Low-lead gasoline with 91 octane number or higher |
| Air Filtration | Paper filter |
| Intake Valve: Opens | 0° BTDC |
| Closes | 40° ATDC |
| Exhaust Valve: Opens | 40° BBDC |
| Closes | 0° ATDC |
| Valve Clearance | IN: 0.05 EX: 0.08 mm (IN: 0.002, EX: 0.003 in.) |
| Pilot Screw Opening | Fixed by idle limiter (1-1/2±1/2) |
| Idle Speed | 1,000 rpm |

| Item | |
|------------------------------|--|
| DRIVE TRAIN | |
| Clutch | Wet multi plate type |
| Transmission | 5-speed constant mesh |
| Primary Reduction | 1.986 |
| Gear Ratio I | 2.500 |
| II | 1.708 |
| III | 1.333 |
| IV | 1.133 |
| V | 0.969 |
| Final Reduction | 2.733, drive sprocket 15T, driven sprocket 41T |
| Gear Shift Pattern | Left foot operated return system |
| ELECTRICAL | |
| Ignition | Battery and ignition coil |
| Ignition Advance: | |
| "F" mark | 10° BTDC |
| Max. advance | 35° |
| RPM from "F" to max. advance | 1,200-2,500rpm |
| Dwell Angle | 190° ± 5° |
| Starting System | Starting motor or kick starter |
| Alternator | Three phase AC Generator 0.21kW/5,000rpm |
| Battery Capacity | 12V-14AH |
| Fuse Capacity | Main: 15amp. Head: 7A Tail: 5A |
| Spark plug | NGK D8EA ND X24ES-U (U.S.A. model) |
| | NGK DR8ES-L ND X24ESR-U (Canadian model) |
| Condenser Capacity | 0.20-0.24 μ F |

SUPPLEMENT TO CB750F3 ('78)

**Engine No. CB750E—2200001 and
subsequent
Frame No. CB750F—3100002 and
subsequent**

**GROUP
27**

1. MAINTENANCE SCHEDULE

Perform the Pre-Ride Inspection described in the Owner's Manual at each maintenance period.

I: INSPECT, CLEAN, ADJUST, OR REPLACE IF NECESSARY.
C: CLEAN R: REPLACE A: ADJUST

| ITEM | FREQUENCY | WHICHEVER → COMES FIRST ↓ EVERY | ODOMETER READING [NOTE (3)] | | | | | | REFER TO |
|------------------------------------|-----------|---|--------------------------------------|------------------------|-------------------------|--------------------------|--------------------------|--------------------------|----------|
| | | | 600 mi (1,000 km) | 3,600 mi (6,000 km) | 7,200 mi (12,000 km) | 10,800 mi (18,000 km) | 14,400 mi (24,000 km) | 18,000 mi (30,000 km) | |
| ENGINE OIL | YEAR | R | REPLACE EVERY 1,800 mi (3,000 km) | | | | | | Page 178 |
| ENGINE OIL FILTER | YEAR | R | R | R | R | R | R | Page 178 | |
| * ENGINE OIL SCREEN | | | | | C | | | Page 179 | |
| CRANKCASE BREATHER | NOTE (1) | | C | C | C | C | C | Page 274 | |
| AIR CLEANER | NOTE (2) | | C | R | C | R | C | Page 226 | |
| * FUEL LINES | | | I | I | I | I | I | Pages 181, 221 | |
| SPARK PLUGS | | | I | R | I | R | I | Page 179 | |
| * VALVE CLEARANCE | | | I | I | I | I | I | Page 181 | |
| * CONTACT BREAKER POINTS | | | I | I | I | I | I | Page 180 | |
| * IGNITION TIMING | | | I | I | I | I | I | Page 180 | |
| * CAMCHAIN TENSION | | A | A | A | A | A | A | Page 181 | |
| * THROTTLE OPERATION | | | I | I | I | I | I | Page 196 | |
| * CARBURETOR IDLE SPEED | | | I | I | I | I | I | Pages 257, 280 | |
| * CARBURETOR CHOKE/ (FAST IDLE) | | | I | I | I | I | I | Page 258 | |
| * CARBURETOR SYNCHRONIZE | | | I | I | I | I | I | Page 257 | |
| DRIVE CHAIN | | | INSPECT EVERY 600 mi (1,000 km) | | | | | | Page 258 |
| BATTERY ELECTROLYTE | MONTH | | I | I | I | I | I | Page 184 | |
| BRAKE FLUID LEVEL | MONTH | | I | I | I | I | I | | |
| * BRAKE FLUID | 2 YEARS | | | | R | | | Page 239 | |
| BRAKE PAD WEAR | | | I | I | I | I | I | Page 267 | |
| * BRAKE LIGHT SWITCH | | | I | I | I | I | I | Page 188 | |
| * HEADLIGHT AIM | | | I | I | I | I | I | Page 222 | |
| CLUTCH FREE PLAY | | | I | I | I | I | I | Page 183 | |
| SIDE STAND | | | I | I | I | I | I | Page 222 | |
| * SUSPENSION | | | I | I | I | I | I | Pages 184~185 | |
| * NUTS, BOLTS, FASTENERS | | | I | I | I | I | I | | |
| ** WHEELS/SPOKES | | | I | I | I | I | I | Pages 228, 241, 270 | |
| ** STEERING HEAD BEARING | | | I | | I | | I | Page 118 | |

** IN THE INTEREST OF SAFETY, WE RECOMMEND THESE ITEMS BE SERVICED ONLY BY AN AUTHORIZED HONDA DEALER.

* SHOULD BE SERVICED BY AN AUTHORIZED HONDA DEALER, UNLESS THE OWNER HAS PROPER TOOLS AND SERVICE DATA, AND IS MECHANICALLY QUALIFIED

NOTES: (1) More frequent service may be required when riding in rain, or at full throttle.

(2) More frequent service may be required when riding in dusty areas.

(3) For higher odometer readings, repeat at the frequency interval established here.

2. CARBURETOR

Carburetor Setting Table

| | |
|---------------------|---------------------|
| Setting number | PD42A |
| Main jet | No. 105 |
| Slow jet | No. 35 |
| Pilot screw opening | 1-3/4 |
| Float height | 14.5 mm (0.571 in.) |

3. CONNECTING ROD

The connecting rod cap tightening torque is changed from 2.0 kg-m (14.5 lbs-ft) to 2.6 kg-m (18.8 lbs-ft).

4. AIR CLEANER

See page 274.

5. SPECIFICATIONS

| Item | |
|--------------------------|---|
| DIMENSION | |
| Overall length | 2,210 mm (87.0 in.) |
| Overall width | 860 mm (33.9 in.) |
| Overall height | 1,185 mm (46.7 in.) |
| Wheelbase | 1,480 mm (58.3 in.) |
| Seat height | 830 mm (32.7 in.) |
| Foot peg height | 325 mm (12.8 in.) |
| Ground clearance | 135 mm (5.3 in.) |
| Dry weight | 232.5 kg (512.6 lb.) |
| FRAME | |
| Type | Double cradle |
| Front suspension, travel | Telescopic fork, travel 141.5 mm (5.6 in.) |
| Rear suspension, travel | Swing arm, travel 86.3 mm (3.4 in.) |
| Front tire size, type | 3.25H-19-4PR, Rib |
| air pressure | Up to 90 kg (200 lb.) load: 2.0 kg/cm ² (28 psi) |
| | Up to vehicle capacity load: 2.25 kg/cm ² (32 psi) |
| Rear tire size, type | 4.00H-18-4PR Block |
| air pressure | Up to 90 kg (200 lb.) load: 2.0 kg/cm ² (28 psi) |
| | Up to vehicle capacity load: 2.8 kg/cm ² (40 psi) |
| Front brake | Disc brake |
| Rear brake | Disc brake |
| Fuel capacity | 18 lit. (4.8 U.S. gal., 4.0 Imp. gal.) |
| Fuel reserve capacity | 4.5 lit. (1.2 U.S. gal., 1.0 Imp. gal.) |
| Caster angle | 62.5° |
| Trail length | 113.5 mm (4.47 in.) |
| Front fork oil capacity | 145-155 cc (5.3-5.4 ounces.) |

| Item | |
|---|--|
| ENGINE Type Cylinder arrangement Bore and stroke Displacement Compression ratio Carburetor, venturi dia. Valve train Oil capacity Lubrication system Fuel required Air cleaner Intake valve: opens closes Exhaust valve: opens closes Valve clearance Pilot screw opening Idle speed | Air cooled 4 stroke O.H.C. engine 4 cylinder in line 61.0×63.0 mm (2.402×2.480 in.) 736 cc (44.9 cu in.) 9.0 : 1 Four piston valve type, venturi dia. 28 mm (1.102 in.) Chain driven over head camshaft 3.5 lit. (3.7 U.S. qt., 3.1 Imp. qt.) Forced pressure and dry sump Low-lead gasoline with 91 reserch octane rating or 86 pump octane or higher Paper filter 5° BTDC 40° ATDC 40° BBDC 5° ATDC IN: 0.05 mm (0.002 in., EX: 0.08 mm (0.003 in.) Fixed by idle limiter (1-3/4) 1,000rpm |
| DRIVE TRAIN Clutch Transmission Primary reduction Gear ratio: 1st " 2nd " 3rd " 4th " 5th Final reduction Gearshift pattern | Wet multi plate type 5-speed constant mesh 1.986 2.500 1.708 1.333 1.133 0.969 3.071 Left foot operated return system |
| ELECTRICAL Ignition Ignition advance: "F" mark Max. advance RPM from "F" to max. advance Dwell angle Starting system Alternator Battery capacity Fuse capacity Spark plug Condenser capacity | Battery and ignition coil 10° BTDC 35° 1,200-2,500rpm 190°±5° Starting motor or kick starter Three phase AC generator 0.21 kW/5,000rpm 12V14AH Main: 15A, Head: 7A, Tail: 5A U.S.A. model: NGK D8EA or ND X24ES-U Canadian model: NGK DR8ES-L or ND X24ESR-U 0.22-0.26 μF |

